

39 TRILLIUM

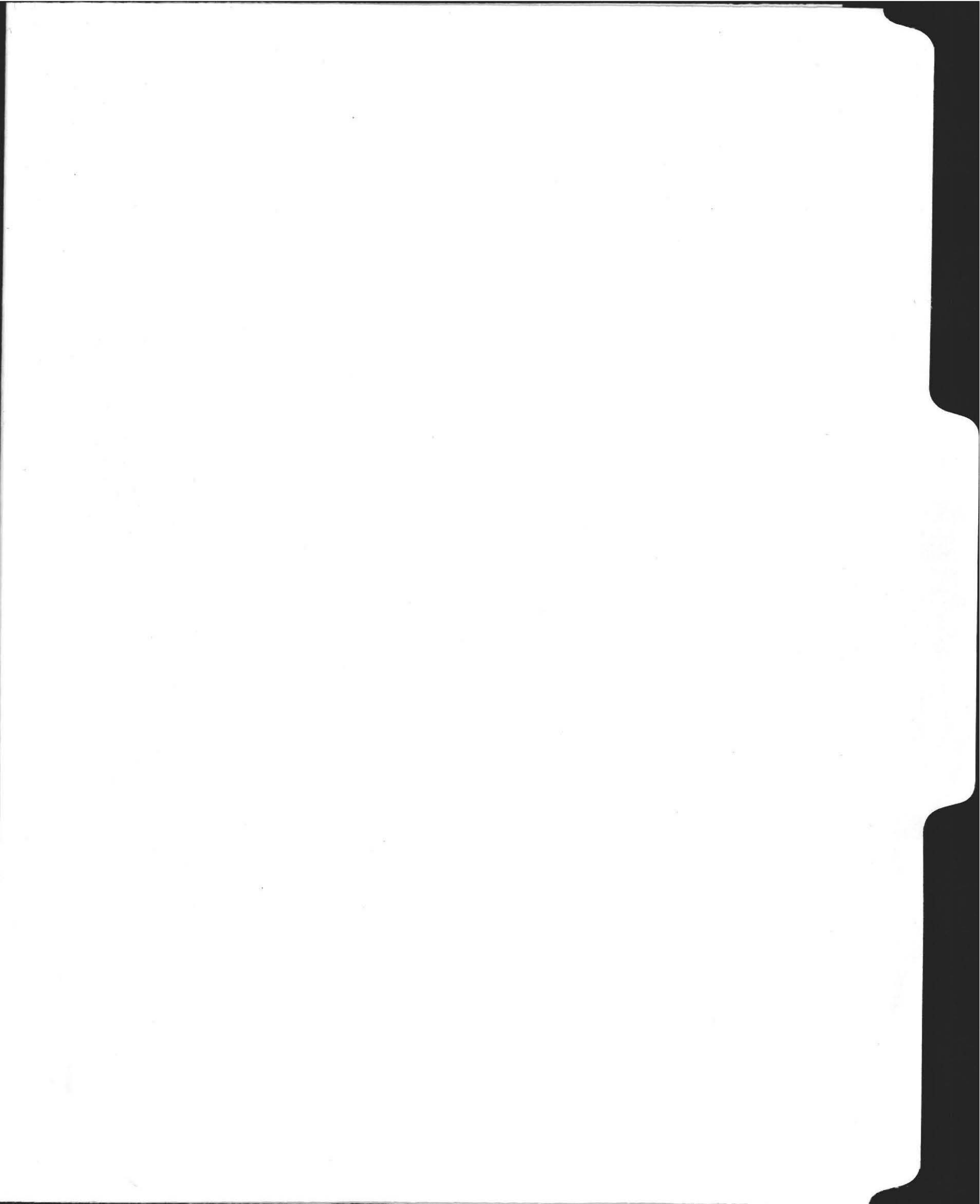

AMHERST PUBLIC HEALTH DEPARTMENT

August 2012
INVOICE

Bangs Community Center
70 Boltwood Walk
Amherst, MA 01002

DATE: August 21, 2012

TO John Katzenbach
39 Trillium
Amherst, MA 01002

RE: Invoice for Septic Title V witness

Services provided by Edmund Smith

PAYMENT TERMS: Due Upon Receipt

QUANTITY	DESCRIPTION	UNIT PRICE	LINE TOTAL
1.00	Septic Title V witness	\$ 200.00	\$ 200.00
	this invoice is due / please remit to the address above		
SUBTOTAL			\$ 200.00
SALES TAX			
TOTAL			\$ 200.00

*mailed to Betty Egan
8/21/2012*

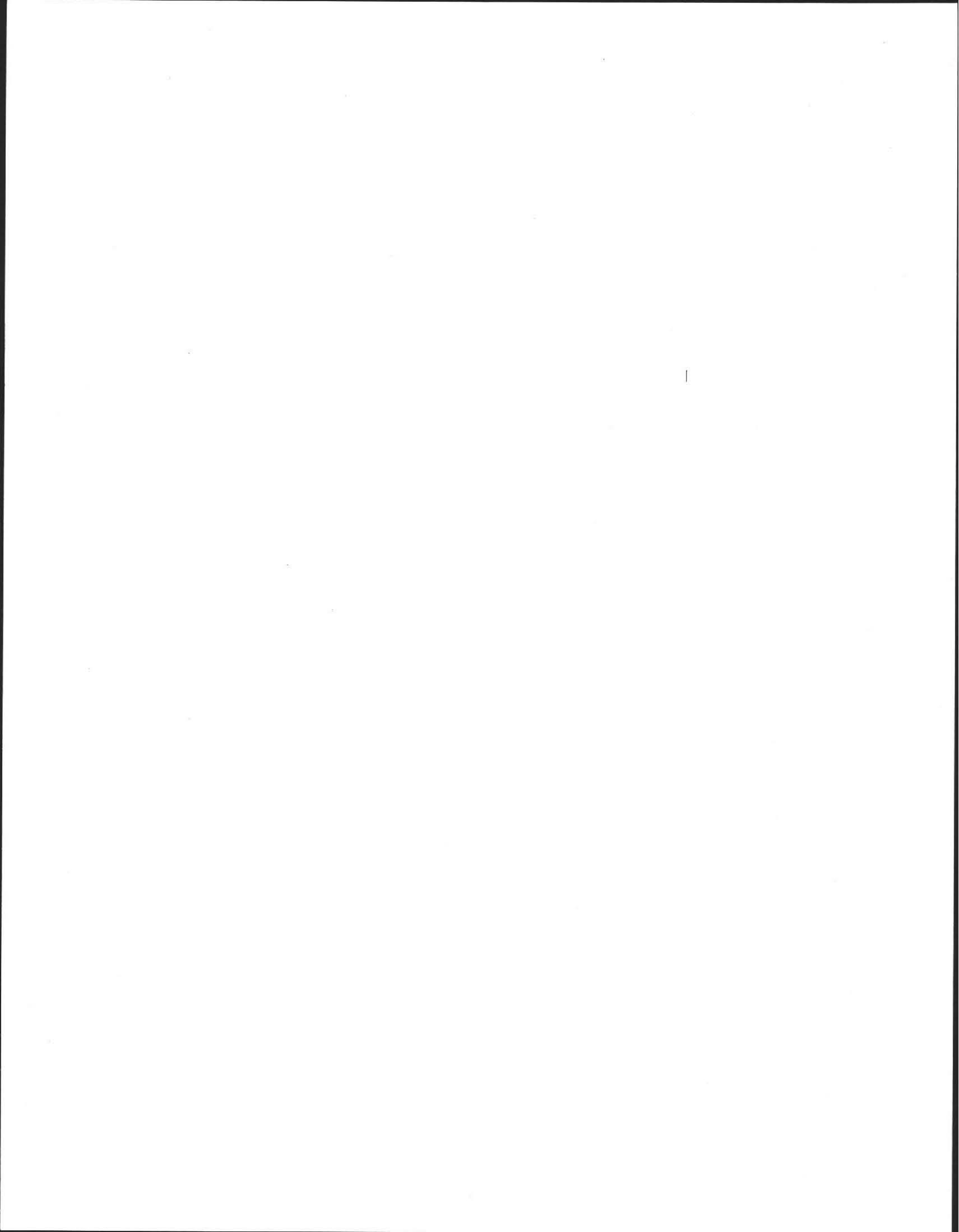

PROFILE OF LOWER LEACH PIT A-A'

STEVEN CAHILLANE, C+C CONTRACTORS, LEEDS, MASS.

SITE: LOT 63, AMHERST WOODS, AMHERST, MASS.

Prepared By: Filios Enterprises, Inc., 69 Pelham Rd, Amherst, Mass. 01002

Scale: Horiz. 1"=10', Vertical 1"=3'

June 9, 1988 EK. Rev. 6/21/88

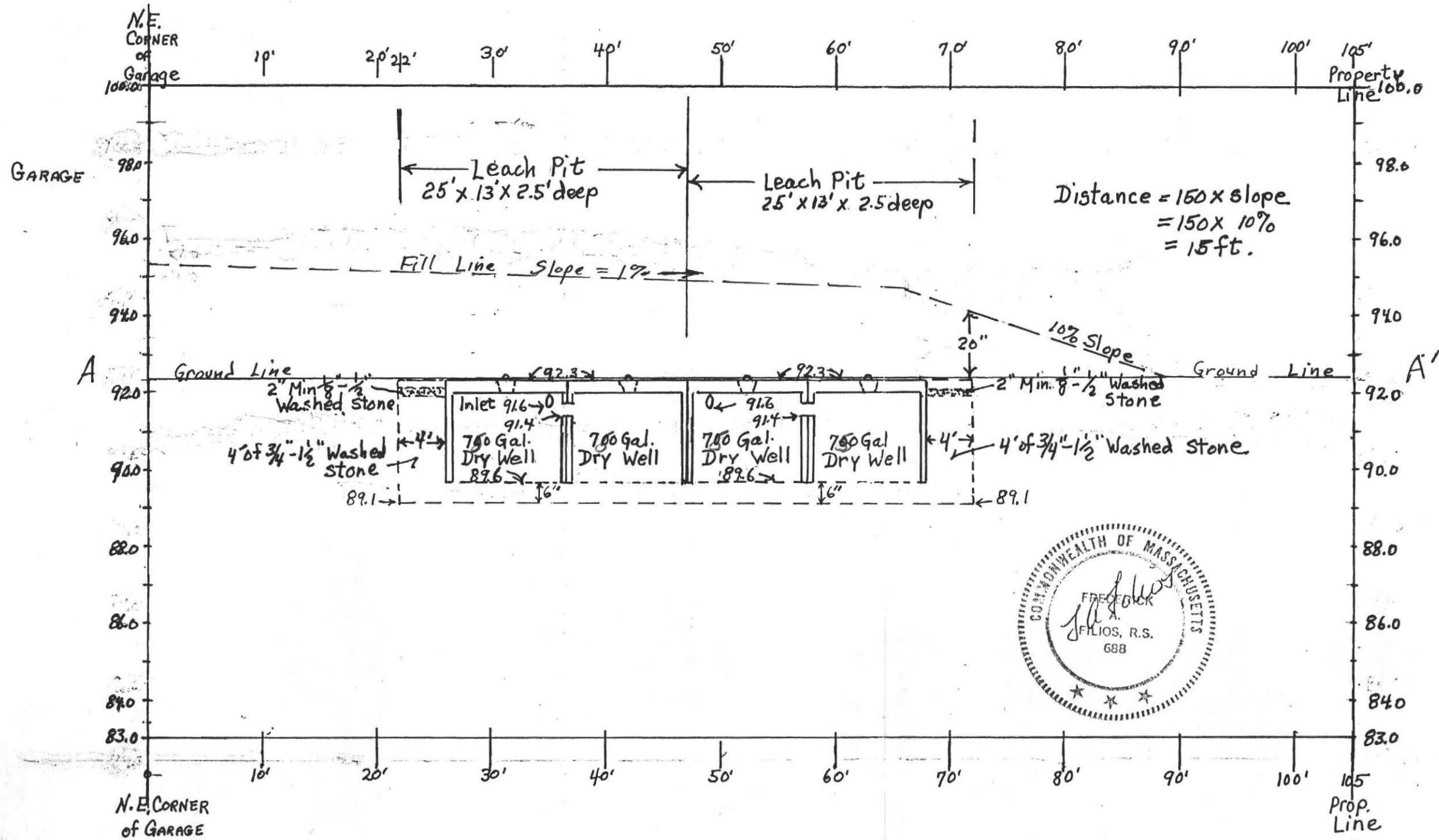

HEALTH DEPARTMENT
JUN 21 1988

8/7/2012

Time ✓

passed -

w/ Alan Weiss

PROFILE OF LOWER LEACH PIT
STEVEN CAHILLANE, C+C CONTRACTORS
SITE: LOT 63, AMHERST WOODS, AMHERST
 Prepared By: Filios Enterprises, Inc., 69 Pelham
 Scale: Horiz. 1" = 10', Vertical 1" = 3'

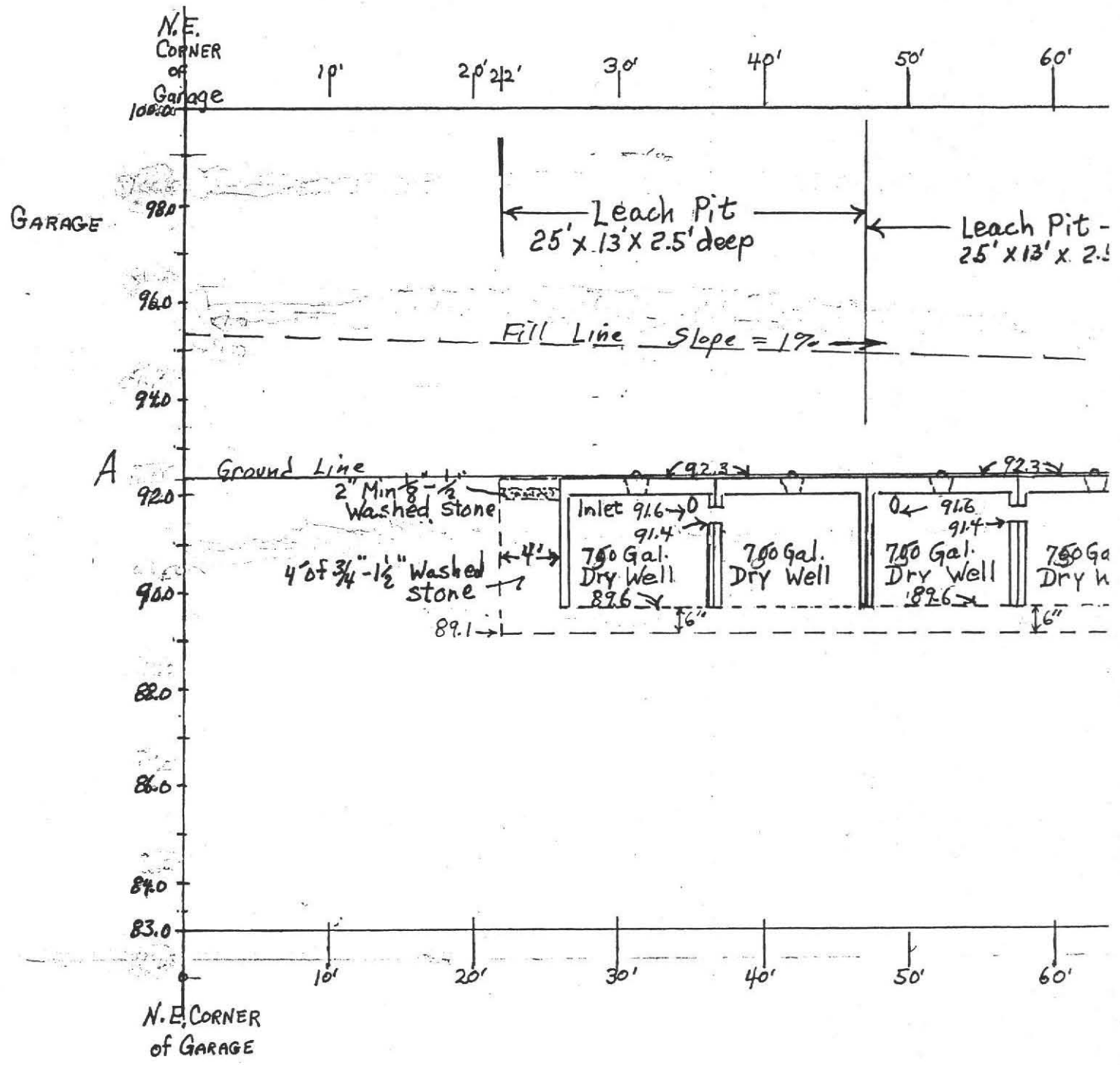

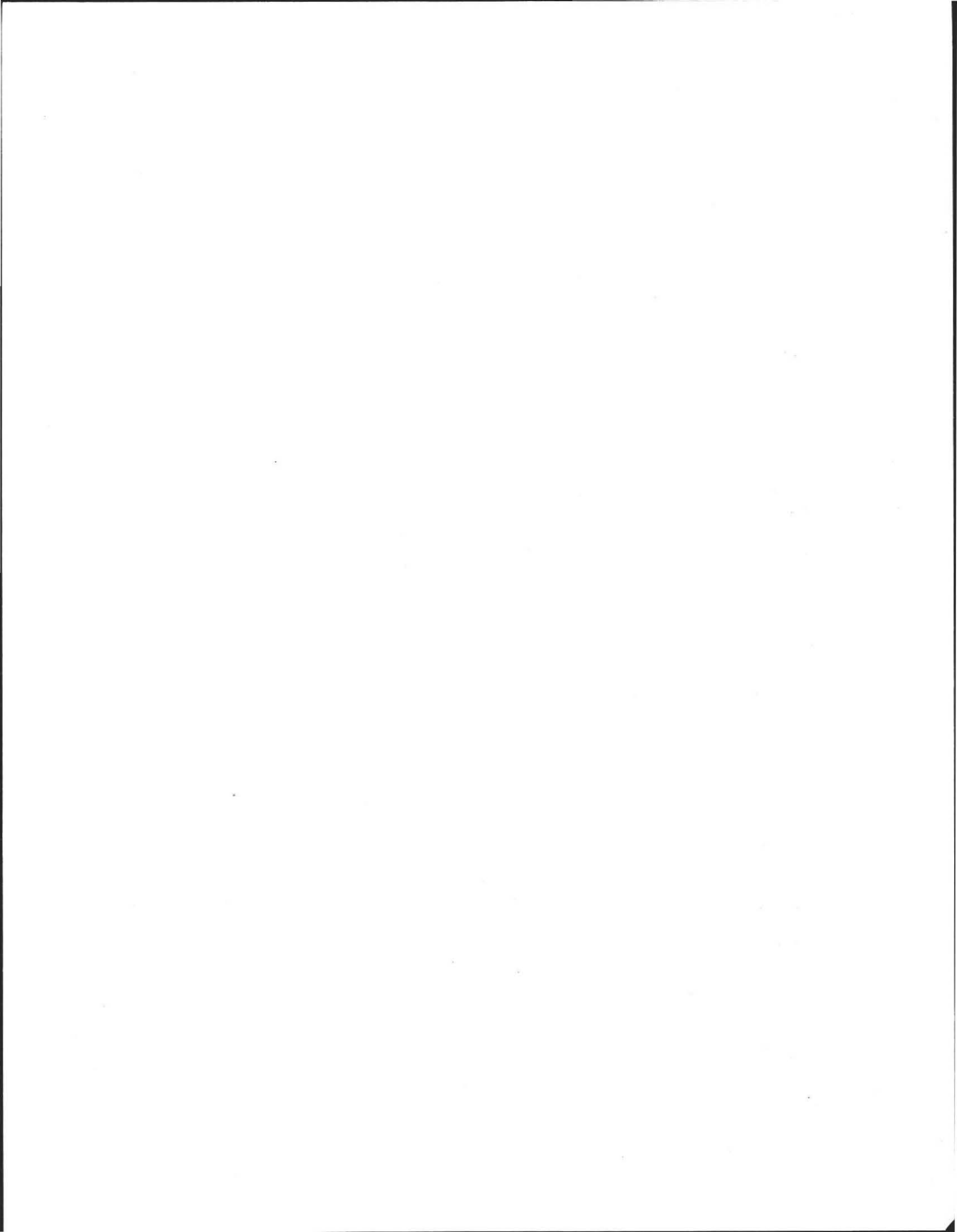

A-A'

LEEDS, MASS.
ST, MASS.

Rd, Amherst, Mass. 01002

June 9, 1988 EK. Rev. 6/21/88

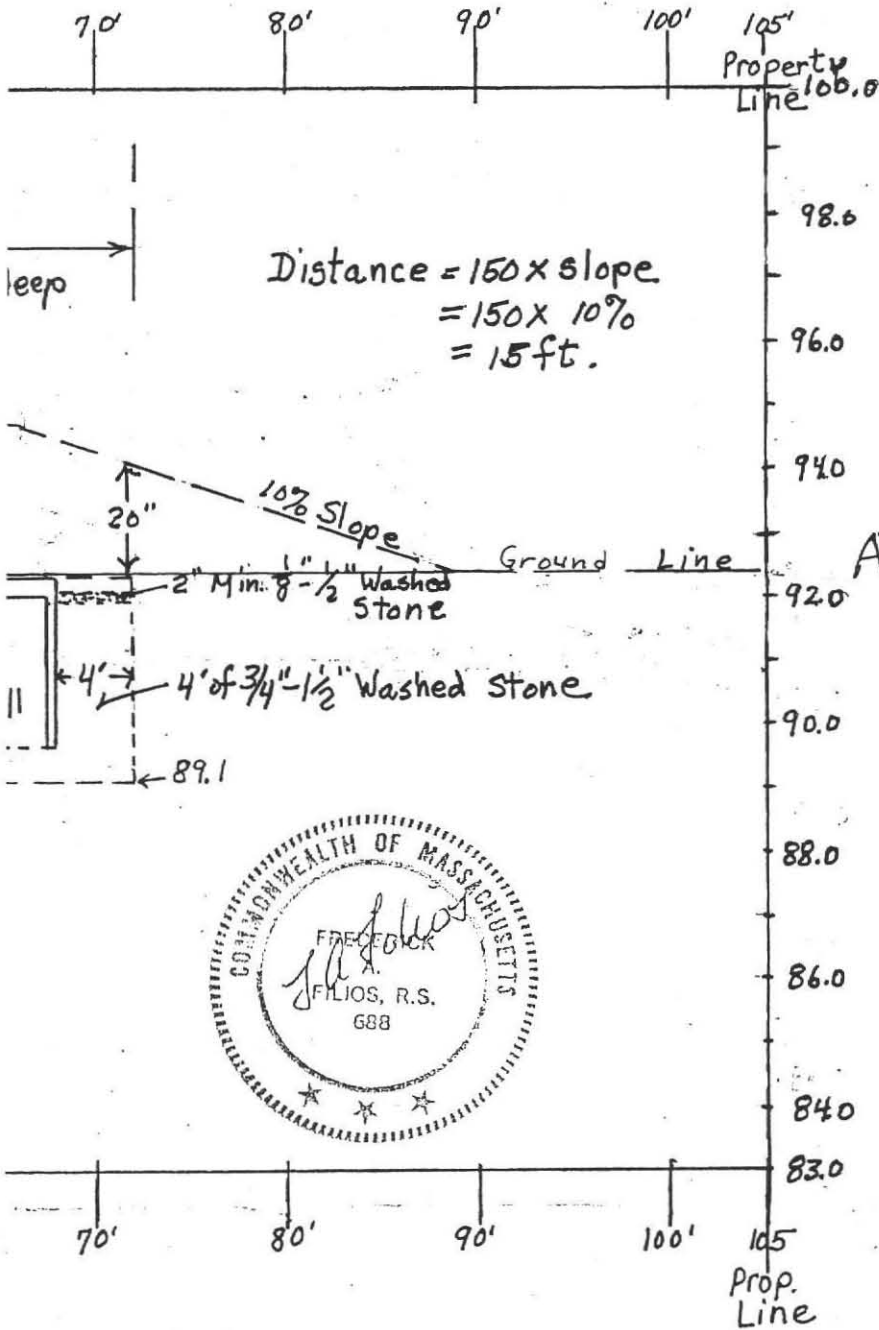

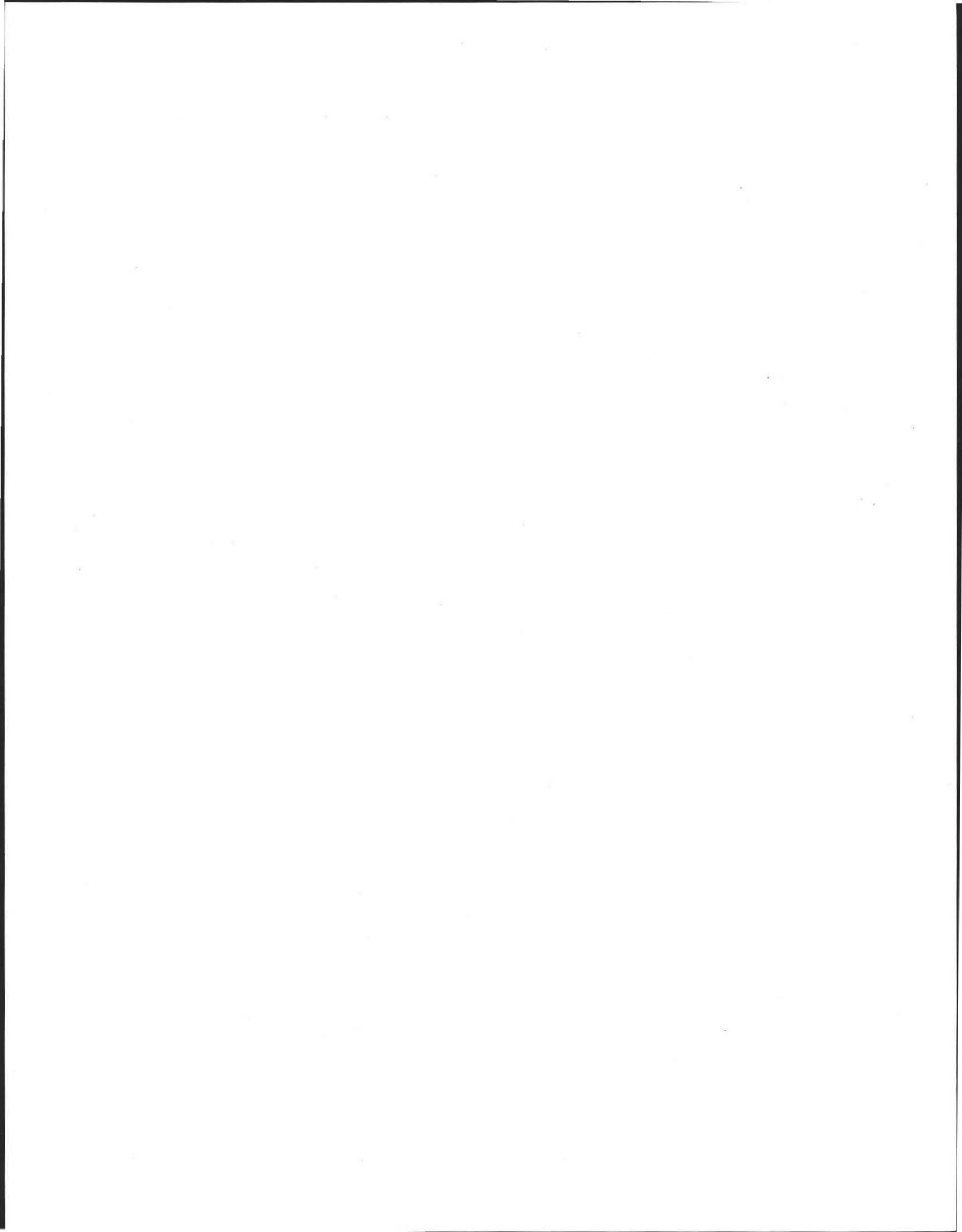

No.

THE COMMONWEALTH OF MASSACHUSETTS

BOARD OF HEALTH

OF

Application for Disposal Works Construction Permit

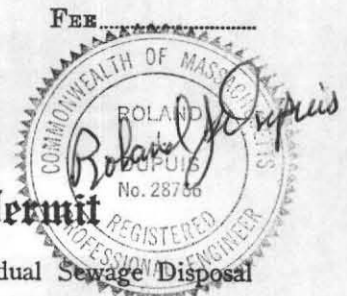

Application is hereby made for a Permit to Construct () or Repair () an Individual Sewage Disposal

System at:

Amherst Woods

Lot No 63

Steve Cahillane, etc Contractors

Leeds, MA

Owner

Address

Installer

Address

Size Lot 1.55 Acres Sq. feet

Type of Building

Dwelling - No. of Bedrooms 5 Expansion Attic () Garbage Grinder ()

Other - Type of Building No. of persons Showers () - Cafeteria ()

Other fixtures

Design Flow 55 gallons per person per day. Total daily flow 1345 gallons.

Septic Tank - Liquid capacity 2000 gallons Length 12.5 Width 5'8" Diameter Depth 5'4"

Disposal Trench - No. Width Total Length Total leaching area sq. ft.

Seepage Pit No. 4 Diameter 25x13' Depth below inlet 2.5' Total leaching area 1930 sq. ft. 5' riser at bottom

Other Distribution box (X) Dosing tank ()

Percolation Test Results Performed by Date

* Test Pit No. 1 10 minutes per inch Depth of Test Pit 10'5" Depth to ground water 130"

Test Pit No. 2 minutes per inch Depth of Test Pit Depth to ground water None (12)

* 10 minutes per inch used in calculations

Description of Soil attached, B of D. Pinski witness

Nature of Repairs or Alterations - Answer when applicable

Agreement:

The undersigned agrees to install the aforescribed Individual Sewage Disposal System in accordance with the provisions of TITLE 5 of the State Sanitary Code - The undersigned further agrees not to place the system in operation until a Certificate of Compliance has been issued by the board of health.

Signed

12-5-88

Application Approved By

Handwritten signature of board member

12/7/88

Application Disapproved for the following reasons:

Permit No. SP-25 Issued Date

THE COMMONWEALTH OF MASSACHUSETTS

BOARD OF HEALTH

Town of Amherst

Certificate of Compliance

THIS IS TO CERTIFY, That the Individual Sewage Disposal System constructed (X) or Repaired () by W. Clark

at Lot # 63 Amherst Woods

has been installed in accordance with the provisions of TITLE 5 of The State Sanitary Code as described in the application for Disposal Works Construction Permit No. SP-25 dated

THE ISSUANCE OF THIS CERTIFICATE SHALL NOT BE CONSTRUED AS A GUARANTEE THAT THE SYSTEM WILL FUNCTION SATISFACTORY.

DATE Dec 16, 1988

Inspector David Zangrilli For Amherst Health Dept.

THE COMMONWEALTH OF MASSACHUSETTS

BOARD OF HEALTH

Town of Amherst

No. SP-25

FEE 90.00

Disposal Works Construction Permit

Permission is hereby granted W. Clark to Construct (X) or Repair () an Individual Sewage Disposal System

at No. Lot 63 Amherst Woods Street

as shown on the application for Disposal Works Construction Permit No. SP-25 Dated

DATE Dec 7, 1988

Signature of David Zangrilli, Board of Health

CHECK OR FILL IN WHERE APPLICABLE

Handwritten notes in the top left corner.

BOARD OF HEALTH

Commissioner for the City of New York

Faint, mostly illegible text in the upper middle section.

Faint, mostly illegible text in the middle section.

Faint, mostly illegible text in the lower middle section.

Faint, mostly illegible text in the lower section.

Faint, mostly illegible text in the lower section.

Faint, mostly illegible text in the bottom section.

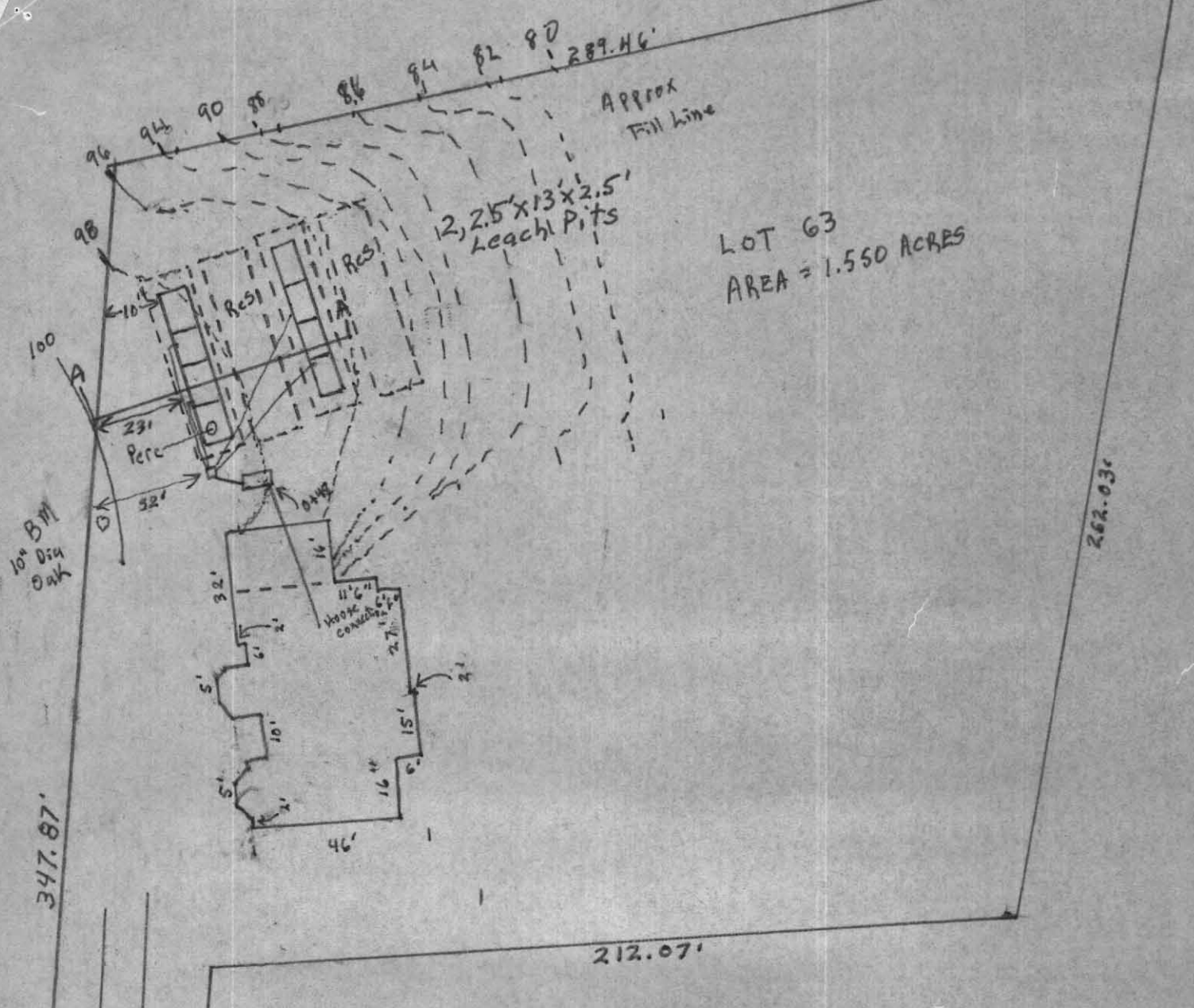

LOT 63
 AREA = 1.550 ACRES

FOR Steven Cahillane
 CC Contractors
 Box
 Leeds Mass 01053

Site Lot 63
 Amherst Woods
 Amherst, MA.

OCT 31 1998

150.00'

LOT 03
AREA = 1.520 ACRES

APPROX
Total Area
1.520 ACRES

2, SR 13x13.2



100
10.00' B.M.

16.75'

213.00'

For Steve Collins
cc Contractors
Box
1000 N. 10th St
Anchorage, AK 99503

YAWMAY

101 11 101

1.5'

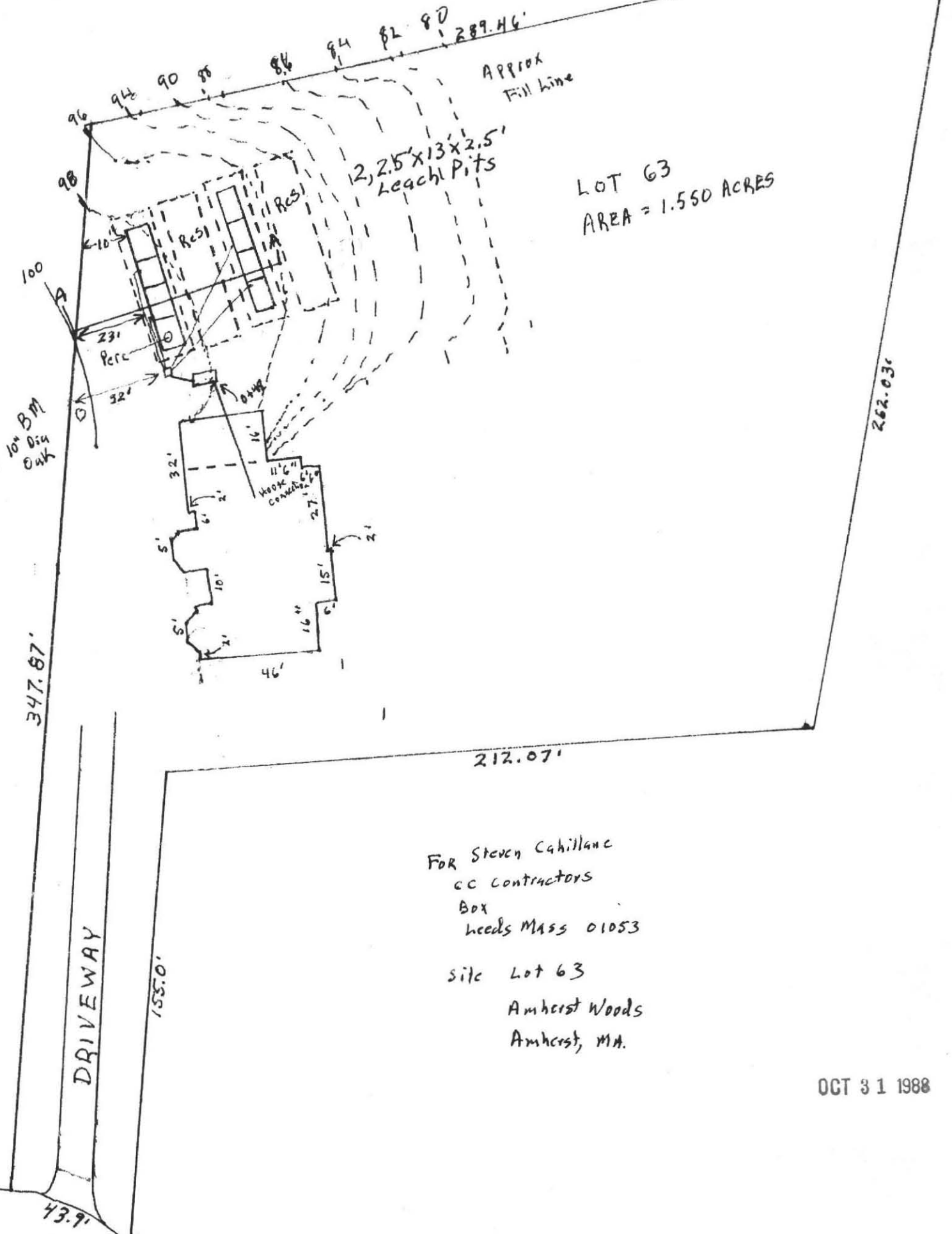

LOT 63
 AREA = 1.550 ACRES

FOR Steven Cahillane
 cc Contractors
 Box
 needs Mass 01053

site Lot 63
 Amherst Woods
 Amherst, MA.

OCT 31 1988

DRIVEWAY

10" BM
 Dia
 Culk

2, 2.5' x 13' x 2.5'
 Leach Pits

Approx
 Fill Line

RES

RES

23'

32'

32'

6'

10'

5'

2'

5'

2'

16"

46'

16'

11.6"

HOOK
 CONNECTION

2.7'

15'

2'

2'

16"

46'

1

1

1

1

1

1

1

1

1

1

1

1

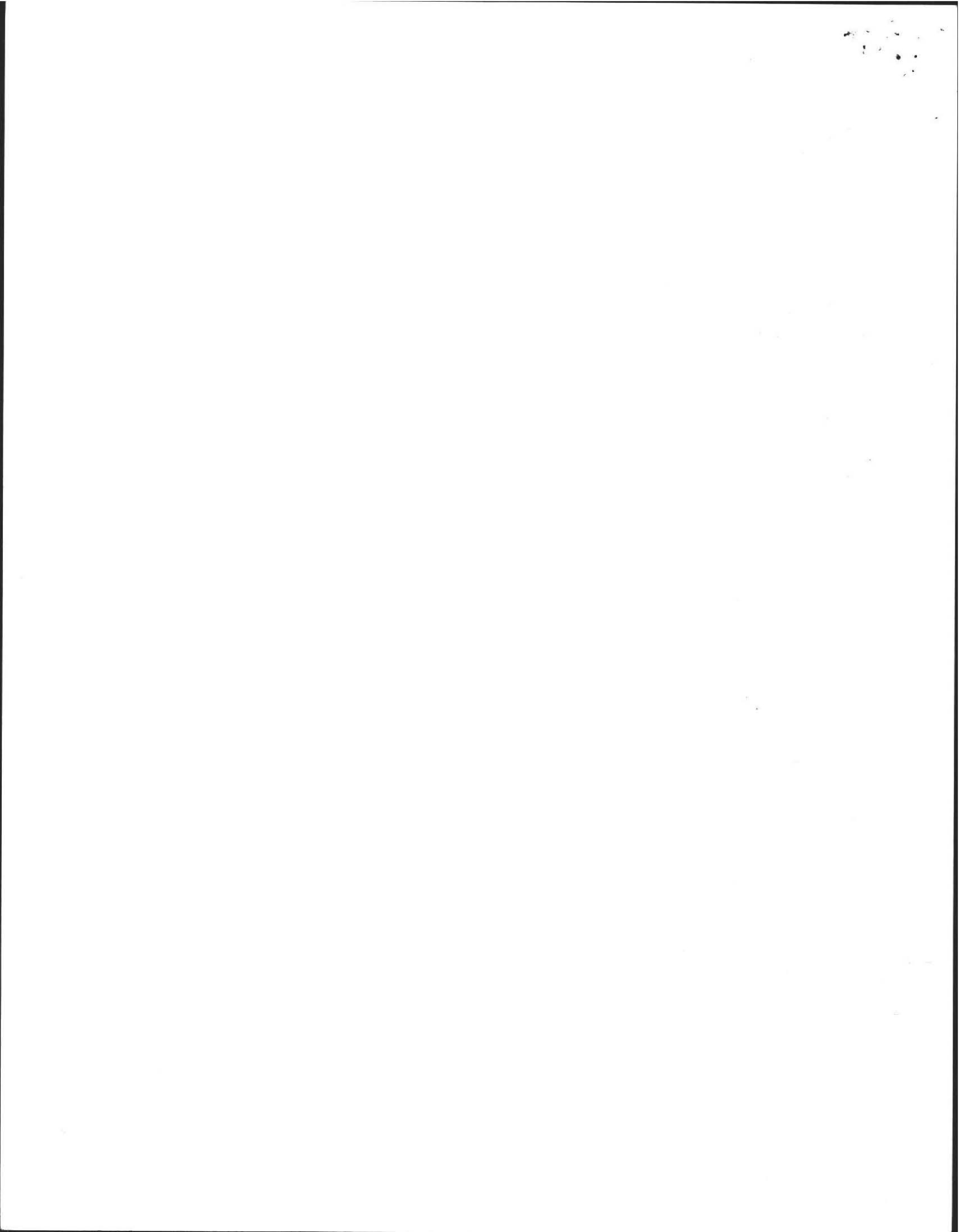

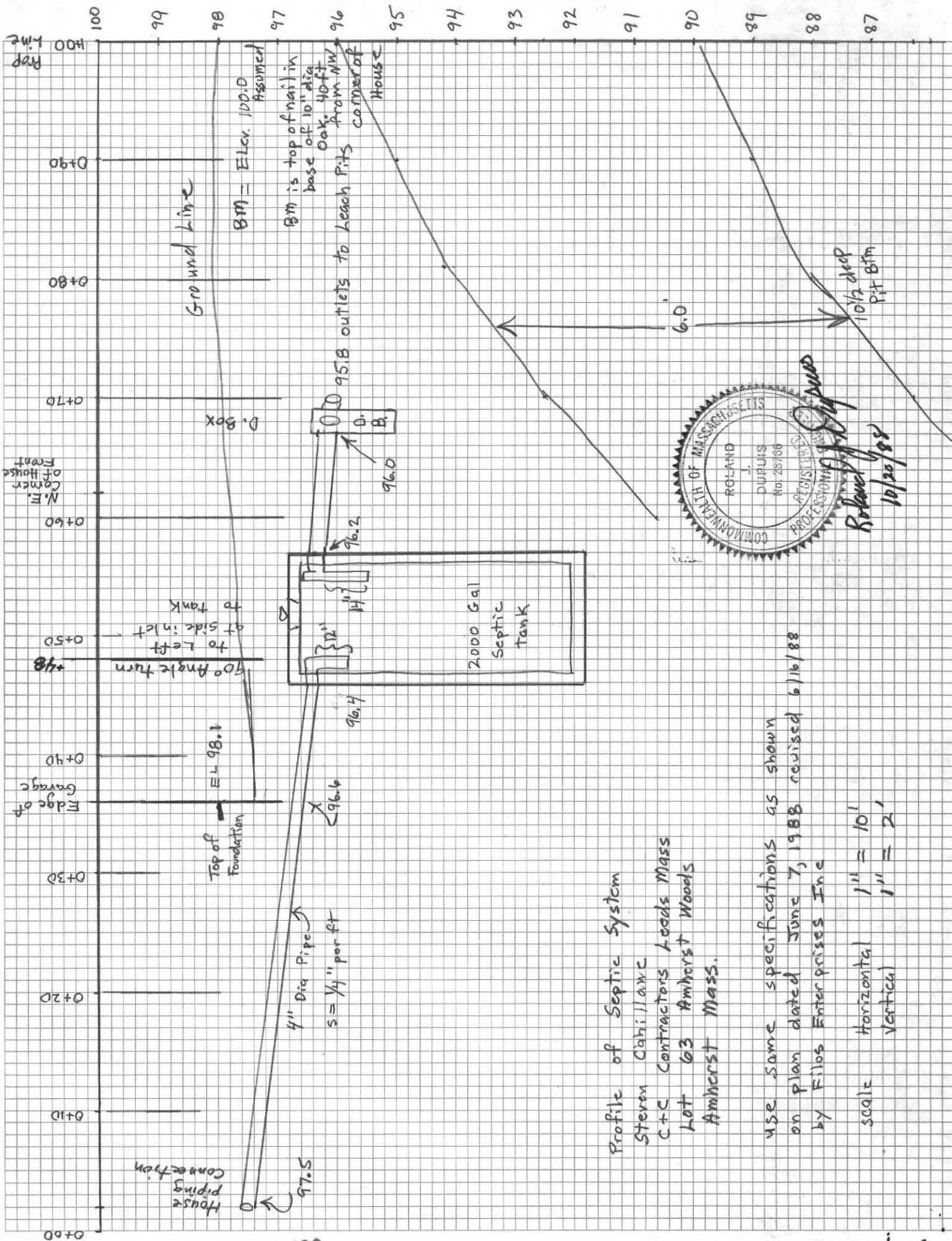

OCT 31 1988

Profile of Septic System
 Steven Cahillane
 C+C Contractors Leads Mass
 Lot 63 Amherst Woods
 Amherst Mass.

use same specifications as shown
 on plan dated June 7, 1988 revised 6/16/88
 by Filos Enterprises Inc

scale horizontal 1" = 10'
 vertical 1" = 2'



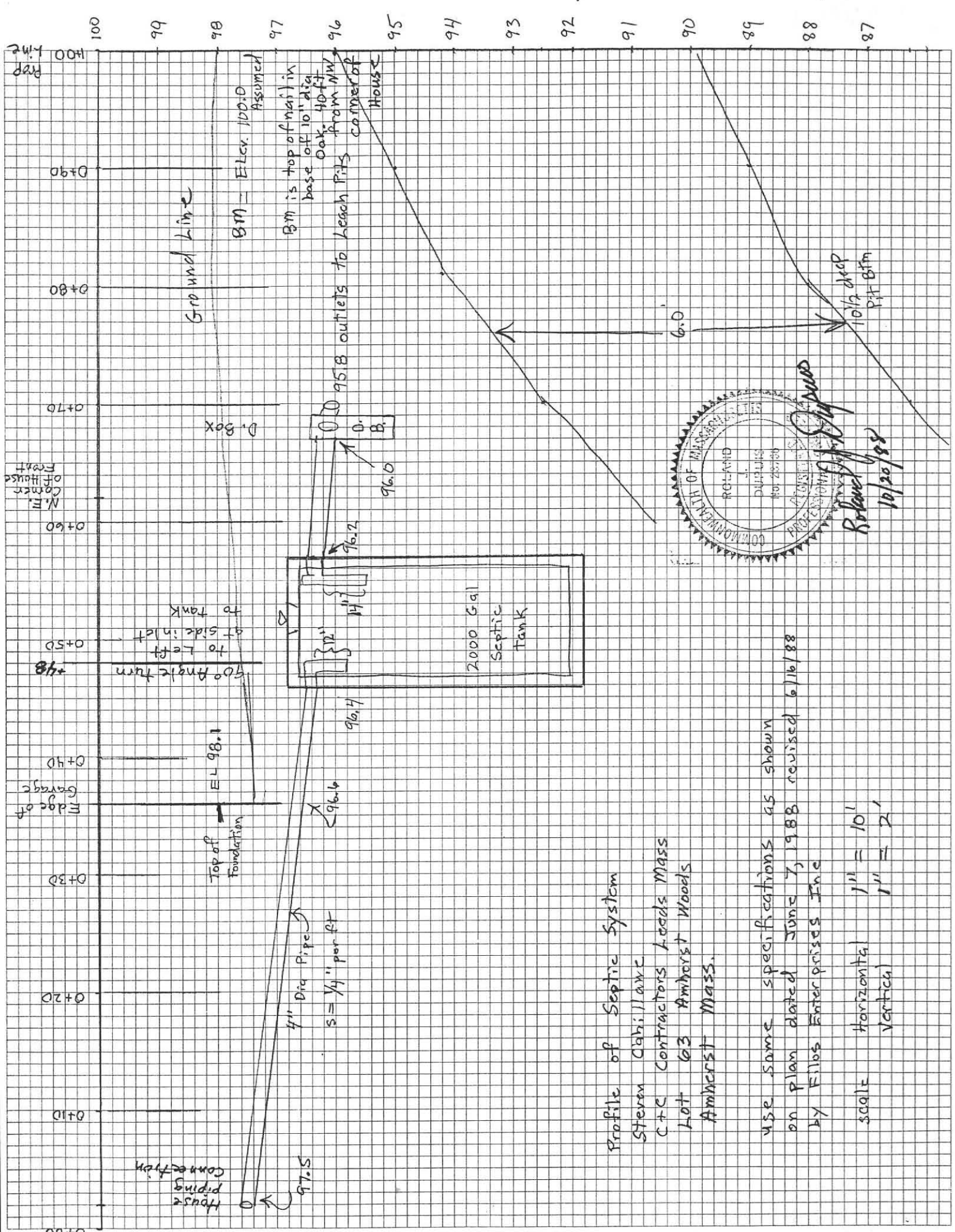

OCT 31 1988

Profile of Septic System
 Steven Cahillane
 C+C Contractors Leads Mass
 Lot 63 Amberst Woods
 Amberst Mass.

use same specifications as shown
 on plan dated June 7, 1988 revised 6/16/88
 by Fillos Enterprises Inc

scale Horizontal 1" = 10'
 Vertical 1" = 2'

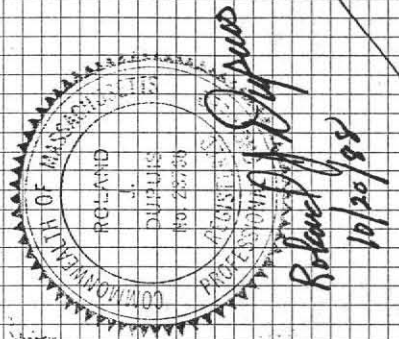

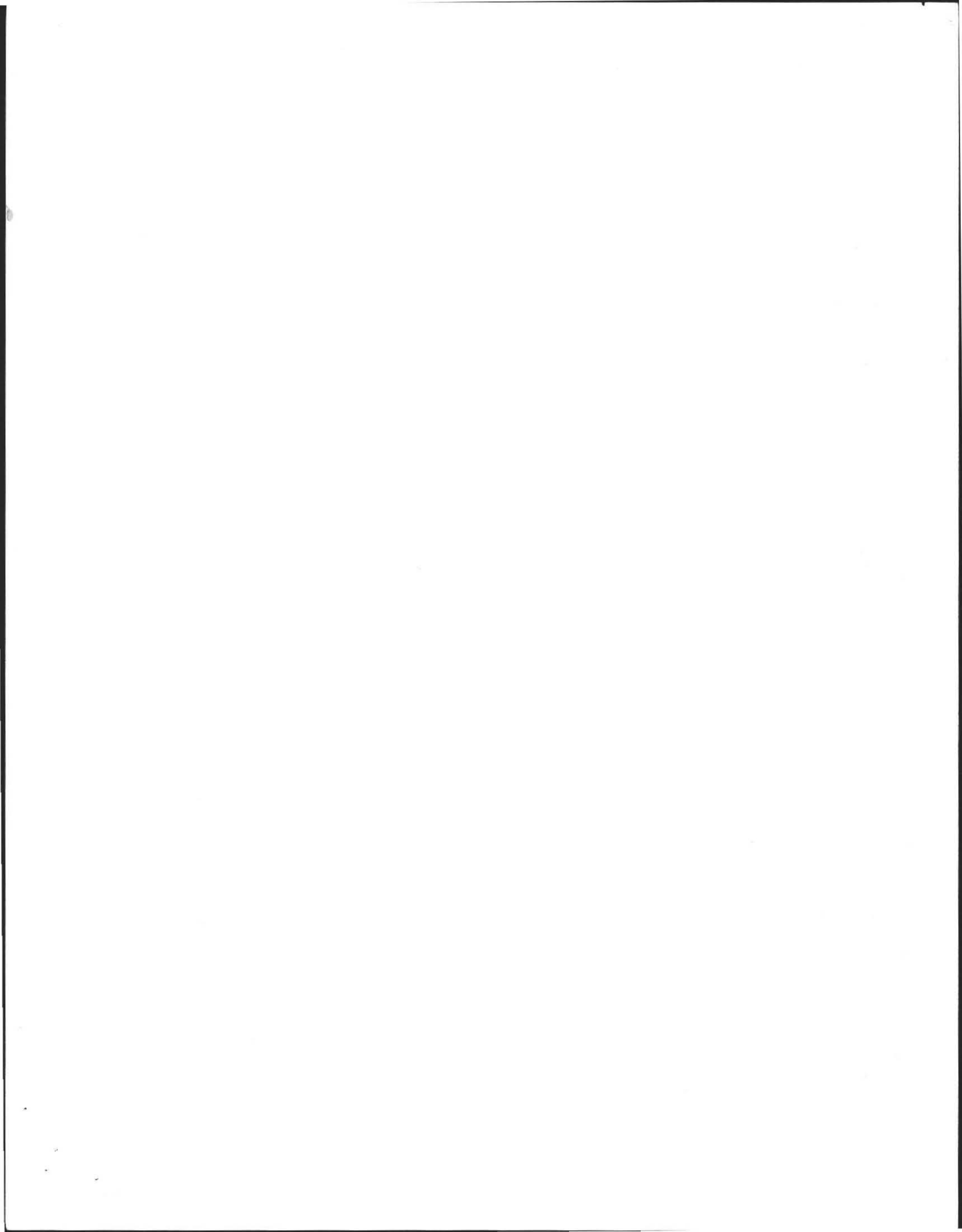

PLAN SHOWING SEWAGE DISPOSAL SYSTEM

FOR: STEVEN CAHILLANE
 C-C CONTRACTORS
 Box
 LEEDS, MA. 01053

BY: FILLIOS ENTERPRISES, INC.
 69 PELHAM RD.
 AMHERST, MA. 01002

DATE: MAY 31, 1988 Rev. 6/21/88

SCALE: 1" = 40'

SITE: LOT 63
 AMHERST WOODS
 AMHERST, MASS.

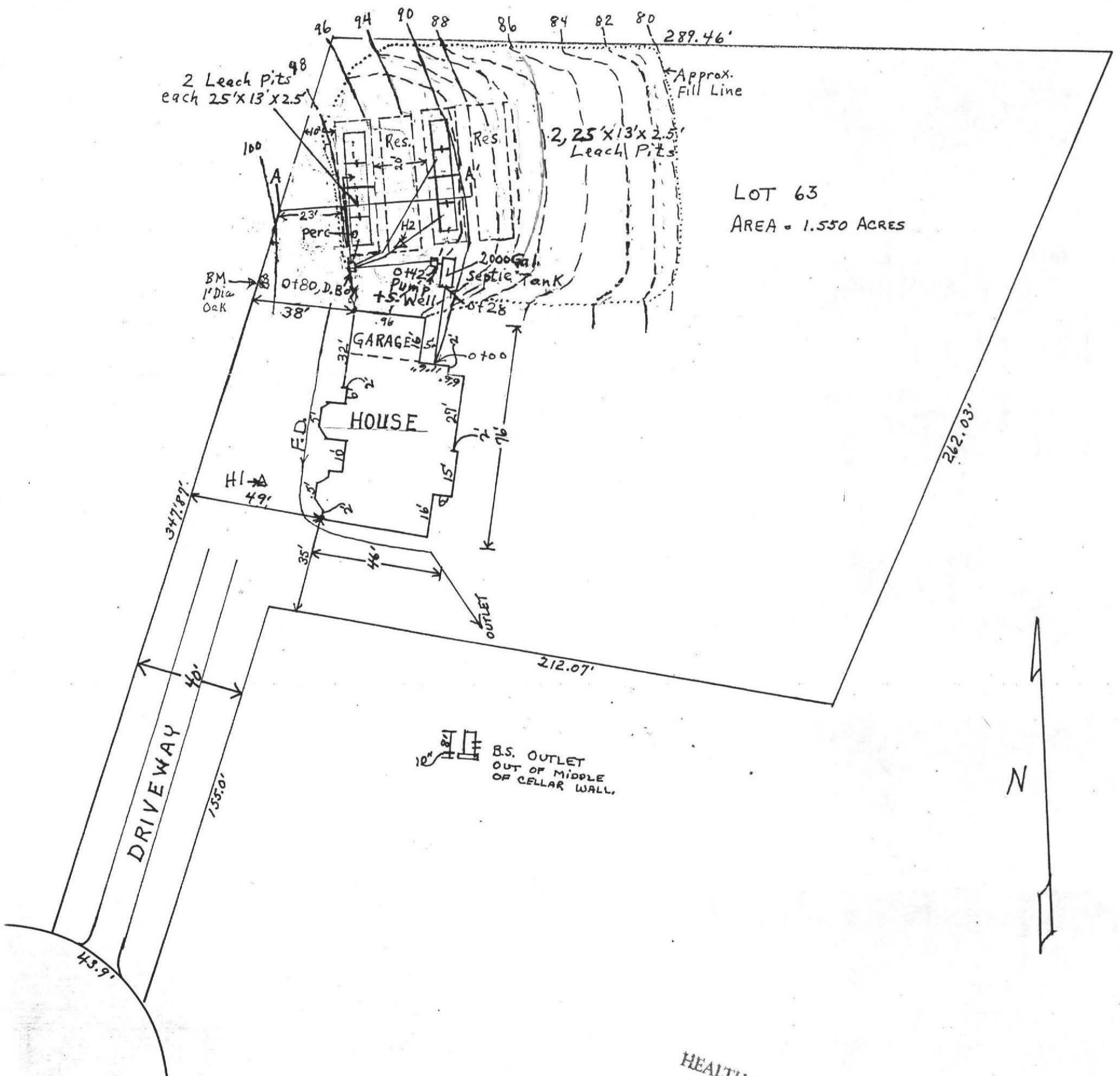

HEALTH DEPARTMENT
 JUN 21 1988

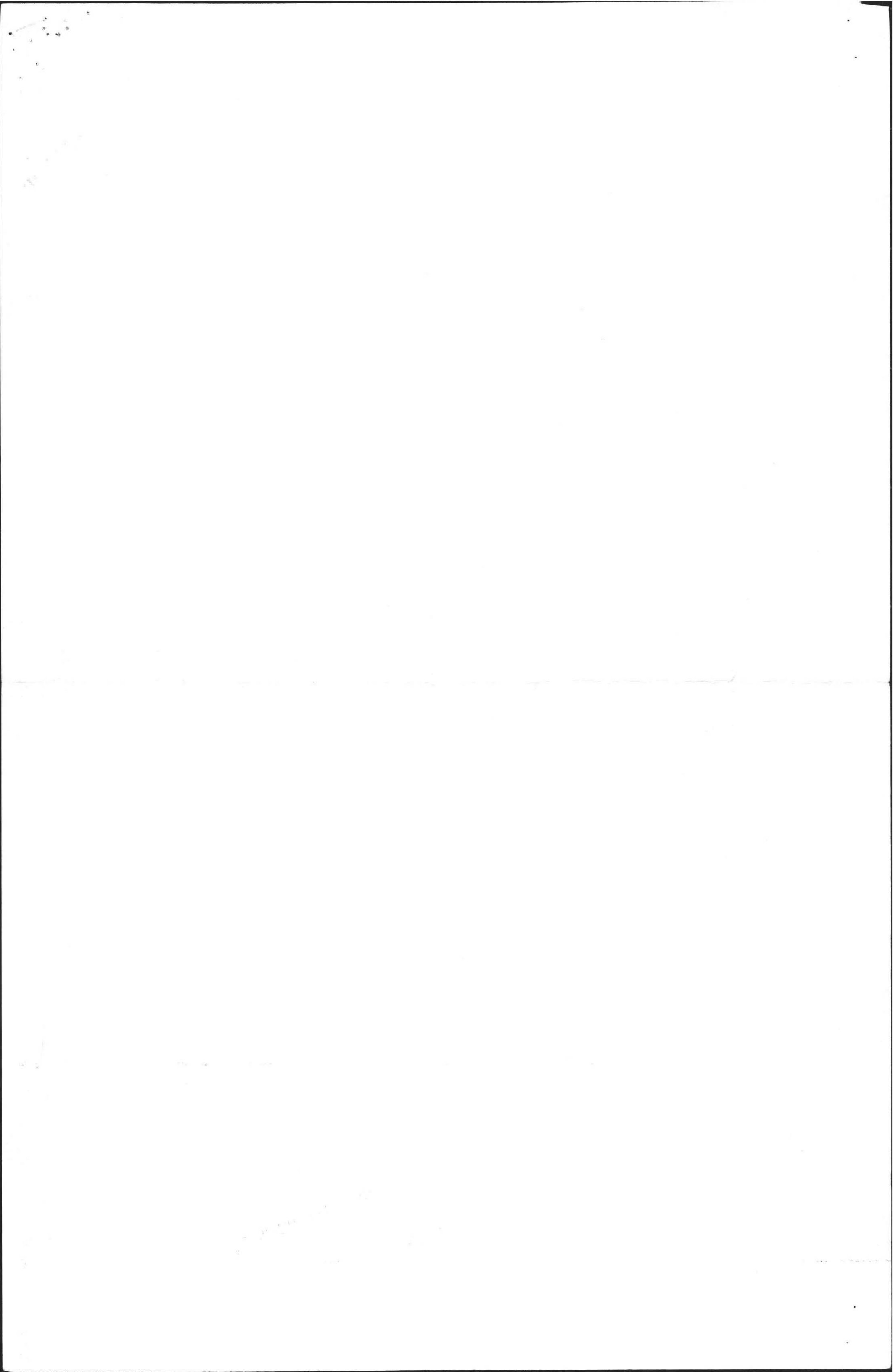

PROFILE OF SEPTIC SYSTEM

BY: FILIOS ENTERPRISES INC.
69 PELHAM RD.
AMHERST MA 01002

DATE: June 7, 1988 E.K. Rev. 6/16/88
SCALE: Horizontal 1" = 10'
Vertical 1" = 3'

FOR: STEVEN CAHILLANE
C+C CONTRACTORS, LEEDS, MASS.
SITE: LOT 63, AMHERST WOODS
AMHERST, MASS.

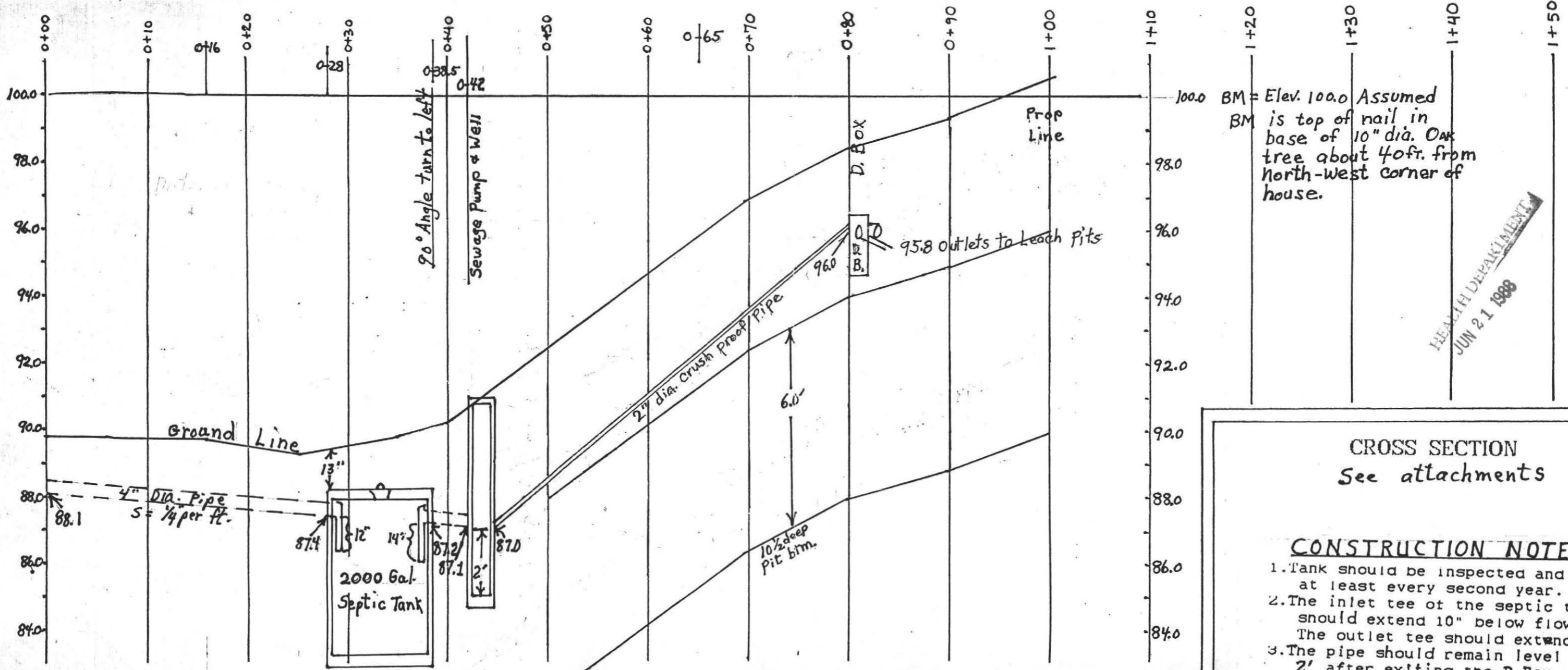

BM = Elev. 100.0 Assumed
BM is top of nail in
base of 10" dia. Oak
tree about 40ft. from
North-west corner of
house.

HEALTH DEPARTMENT
JUN 21 1988

SPECIFICATIONS

All materials and construction will be in accordance with Commonwealth of MA D. E. Q. E. State Environmental Code Title 5.

CALCULATIONS

5 Bedrooms @ 110 Gals + 200% for G.G. = 1100 Gals x 1.25 Amherst req'm't = 1345 Req'd.
Perc Rate: minutes per inch (loading sides 1.00, btm 0.55 Gals/sq. ft.)
Leach System = 4 Leach pits 2.5' x 13' x 2.5' deep
Sides: 2.5' x 2.5' deep x 2 sides = 125 sq. ft. } 157.5 x 1.0 Gals/sq. ft. = 157.5 Gals.
End Area @ 13' x 2.5' deep x 1 end = 32.5 " "
Btm. 2.5' x 13' = 32.5 sq. ft. x 0.55 Gals/sq. ft. = 178.75 Gals + 157.5 = 336.25 Gals
4 Leach pits x 336.25 Gals = 1345 Gallons available

CROSS SECTION
See attachments

CONSTRUCTION NOTES

1. Tank should be inspected and pumped at least every second year.
2. The inlet tee of the septic tank should extend 10" below flow line. The outlet tee should extend 14".
3. The pipe should remain level for 2' after exiting the D.Box.
4. All topsoil should be removed to a distance of 10' around system where fill is to be used.



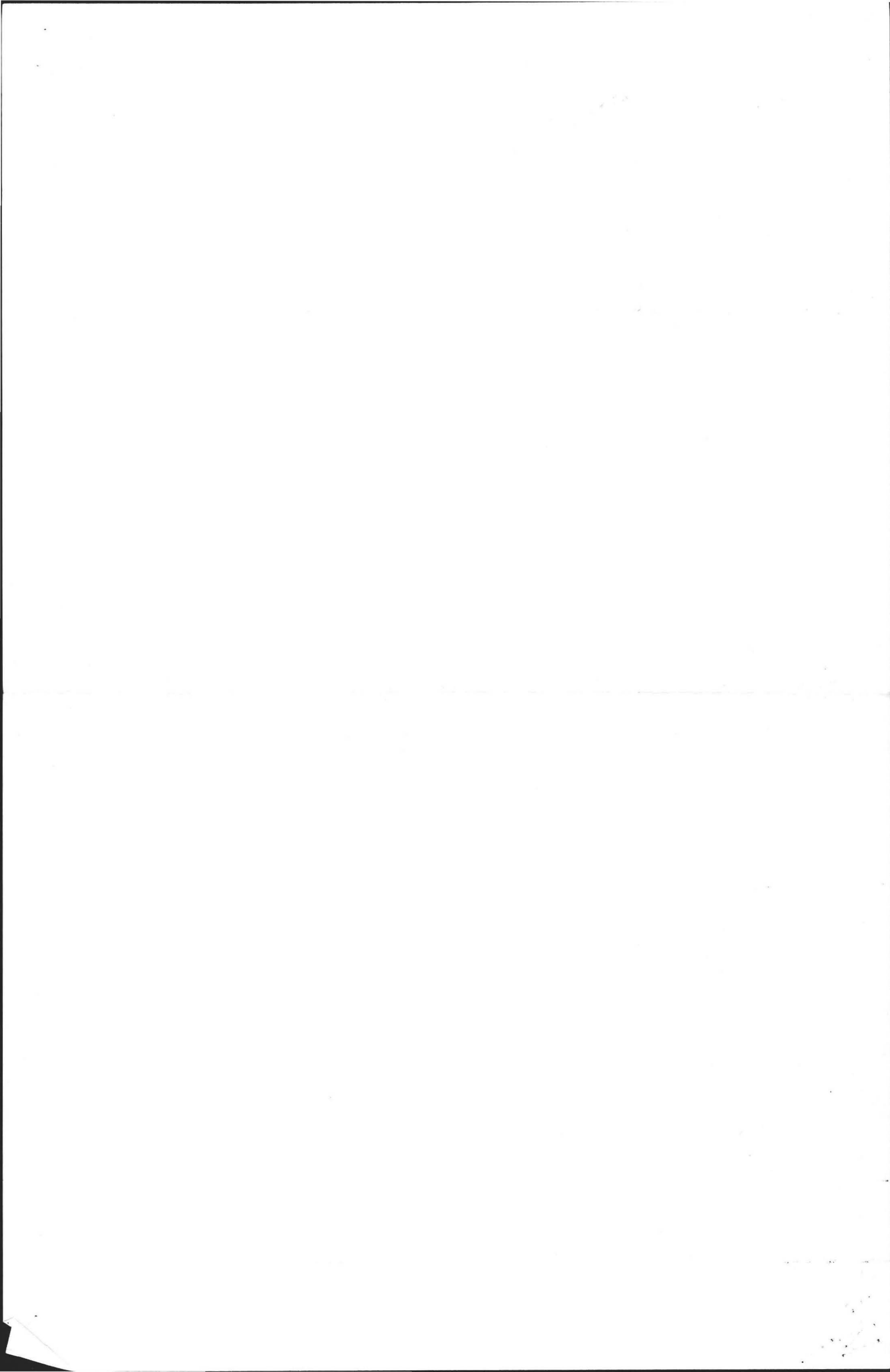

CROSS-SECTION OF LEACH PITS AT A-A'
 STEVEN CAHILLANE, C+C CONTRACTORS LEEDS, MASS.
 SITE: LOT 63, AMHERST WOODS, AMHERST, MASS.

Prepared By: Fillos Enterprises, Inc., 69 Pelham Rd., Amherst, Mass. 01002

Scale: Horiz. 1"=10' Vertical 1"=3'

June 8, 1988

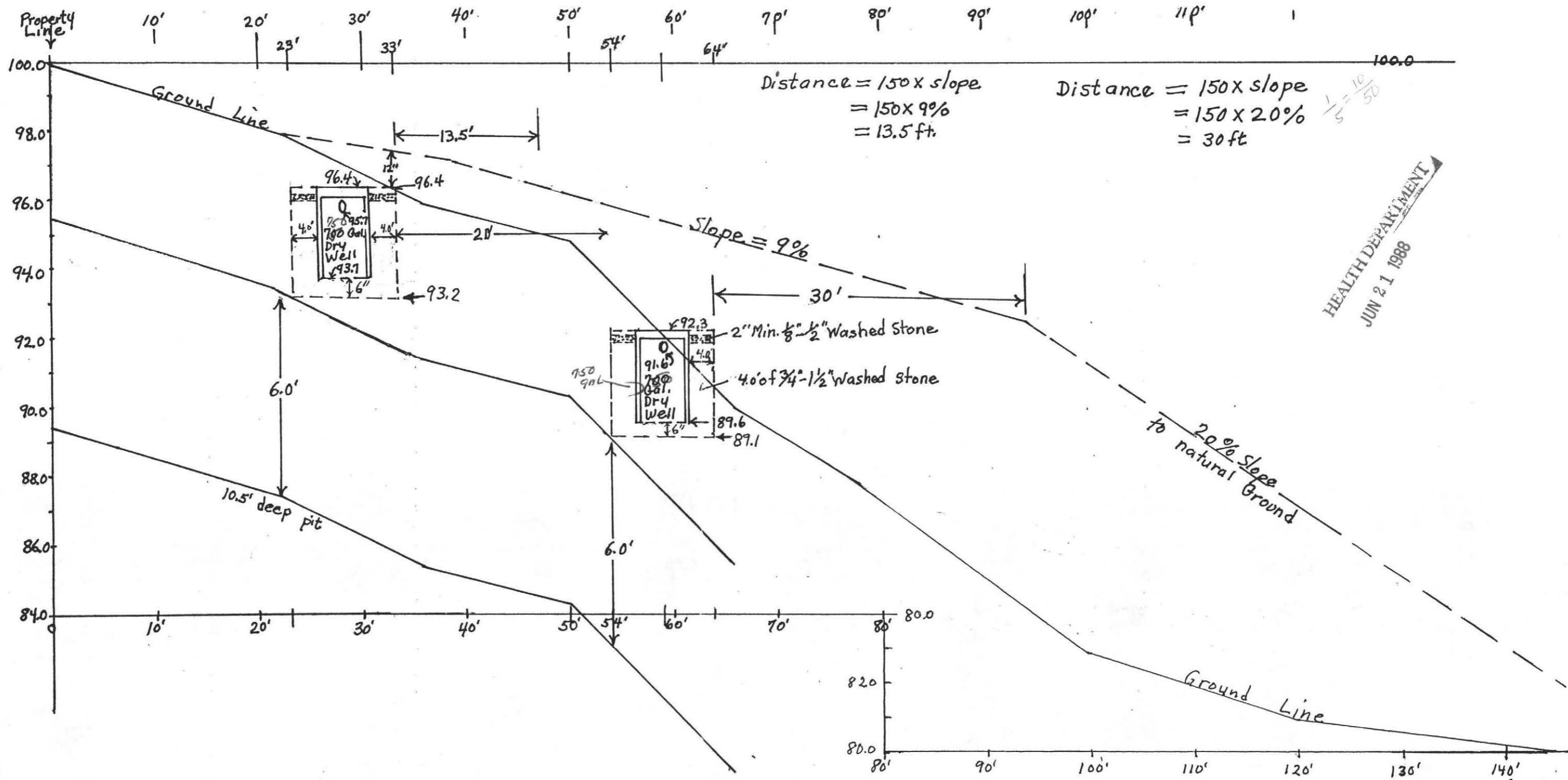

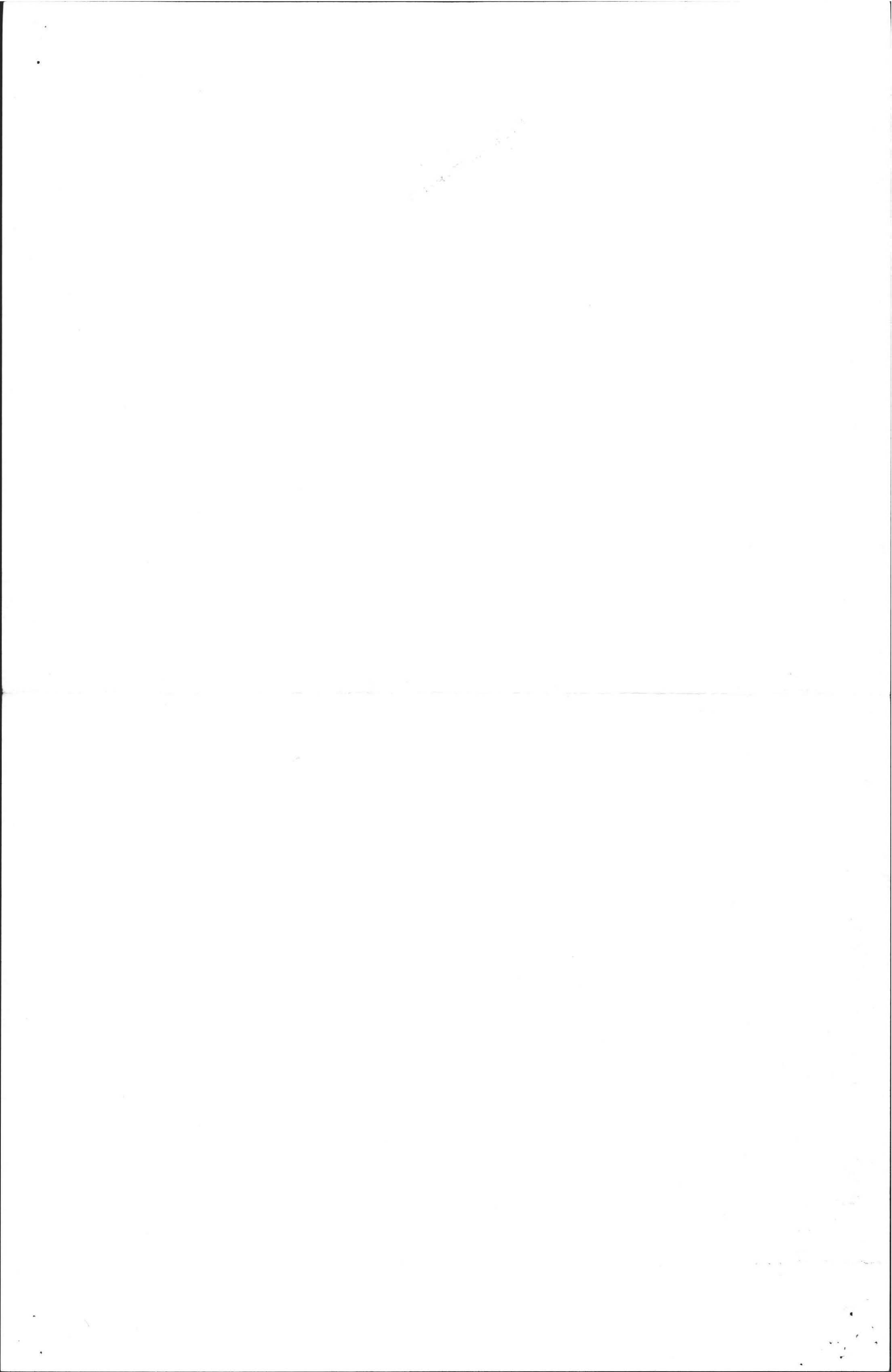

THE COMMONWEALTH OF MASSACHUSETTS

BOARD OF HEALTH

OF

Application for Disposal Works Construction Permit

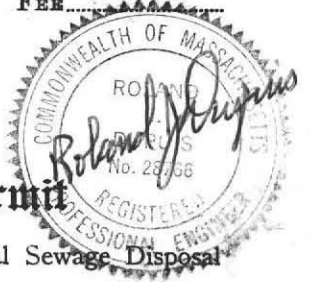

Application is hereby made for a Permit to Construct (✓) or Repair () an Individual Sewage Disposal System at:

System at: 39 Amherst Woods Lot No 63
Steven Cahillane, C/O Contractors needs, MA
W. Clark Installer Shutesbury

Type of Building Dwelling - No. of Bedrooms 5 Expansion Attic () Garbage Grinder ()
Other - Type of Building No. of persons Showers () - Cafeteria ()
Other fixtures

Design Flow 55 gallons per person per day. Total daily flow 1345 gallons.
Septic Tank - Liquid capacity 2000 gallons Length 12.5' Width 5'8" Diameter Depth 5'4"
Disposal Trench - No. Width Total Length Total leaching area sq. ft.
Seepage Pit No. 4 Diameter 25'x13' Depth below inlet 2.5' Total leaching area 1930 sq. ft. side + bottom

Percolation Test Results Performed by Filos Enterprises Date 5/9/88
* Test Pit No. 1 10 minutes per inch Depth of Test Pit 10.5' Depth to ground water seepage at 130"
Test Pit No. 2 10 minutes per inch Depth of Test Pit Depth to ground water None at 12'

Description of Soil attached, B of H. D. Pinski witness

Nature of Repairs or Alterations - Answer when applicable

Agreement: The undersigned agrees to install the aforescribed Individual Sewage Disposal System in accordance with the provisions of TITLE 5 of the State Sanitary Code - The undersigned further agrees not to place the system in operation until a Certificate of Compliance has been issued by the Board of Health.

Signed [Signature] Date 12-5-88
Application Approved By [Signature] Date 12/7/88

Application Disapproved for the following reasons:

Permit No. 88-25 Issued Date

THE COMMONWEALTH OF MASSACHUSETTS

BOARD OF HEALTH

Town of Amherst

Certificate of Compliance

THIS IS TO CERTIFY, That the Individual Sewage Disposal System constructed (✓) or Repaired () by W. Clark Installer at Lot #63 Amherst Woods has been installed in accordance with the provisions of TITLE 5 of The State Sanitary Code as described in the application for Disposal Works Construction Permit No. 88-25 dated

THE ISSUANCE OF THIS CERTIFICATE SHALL NOT BE CONSTRUED AS A GUARANTEE THAT THE SYSTEM WILL FUNCTION SATISFACTORY.

DATE Dec 16, 1988 Inspector David Zagumbi for Amherst Health Dept

THE COMMONWEALTH OF MASSACHUSETTS

BOARD OF HEALTH

Town of Amherst

No. 88-25 FEE 90.00 Pd

Disposal Works Construction Permit

Permission is hereby granted W. Clark to Construct (✓) or Repair () an Individual Sewage Disposal System at No. Lot 63 Amherst Woods as shown on the application for Disposal Works Construction Permit No. 88-25 Dated

DATE Dec 7, 1988 [Signature] Board of Health or Health

CHECK OR FILL IN WHERE APPLICABLE

Town of



AMHERST

Massachusetts

Bettye Anderson Frederic, Director

AMHERST HEALTH DEPARTMENT
70 BOLTWOOD WALK
AMHERST, MA 01002-2128
(413) 253-7077

November 2, 1988

Mr. Steven Cahillane
C & C Builders
Leeds, Massachusetts 01053

Dear Mr. Cahillane:

This office received on October 31, 1988 a revised subsurface sewage disposal system plan for your property at Lot #63, Amherst Woods.

The plan is for the relocation of the septic tank and for the elimination of the pump system at this site. These proposed changes are acceptable.

During this summer you had inquired about the possibility of changing the finished grading and filling needed downslope and in the area where the proposed leaching chambers are to be located.

This office originally approved the design plan for the placement and final grading of fill material as indicated in the cross section of the plan prepared by Fred Filios dated May 31, 1988 revised June 21, 1988 (horizontal extension of fill 30 feet beyond the inlets of the leaching system with 20 per cent slope thereafter to original grade).

The plan presented shows no proposed changes of the filling and final grading needed to insure compliance with Title V Regulation 15.03(7) requirements.

Please instruct your engineer to have the appropriate design revision prepared if you intend to pursue your request.

Please contact this office (253-7077) if you have any questions relative to this matter.

Sincerely,

Dennis A. Pinski, C.H.O., R.S.
Health Agent

DAP:klw

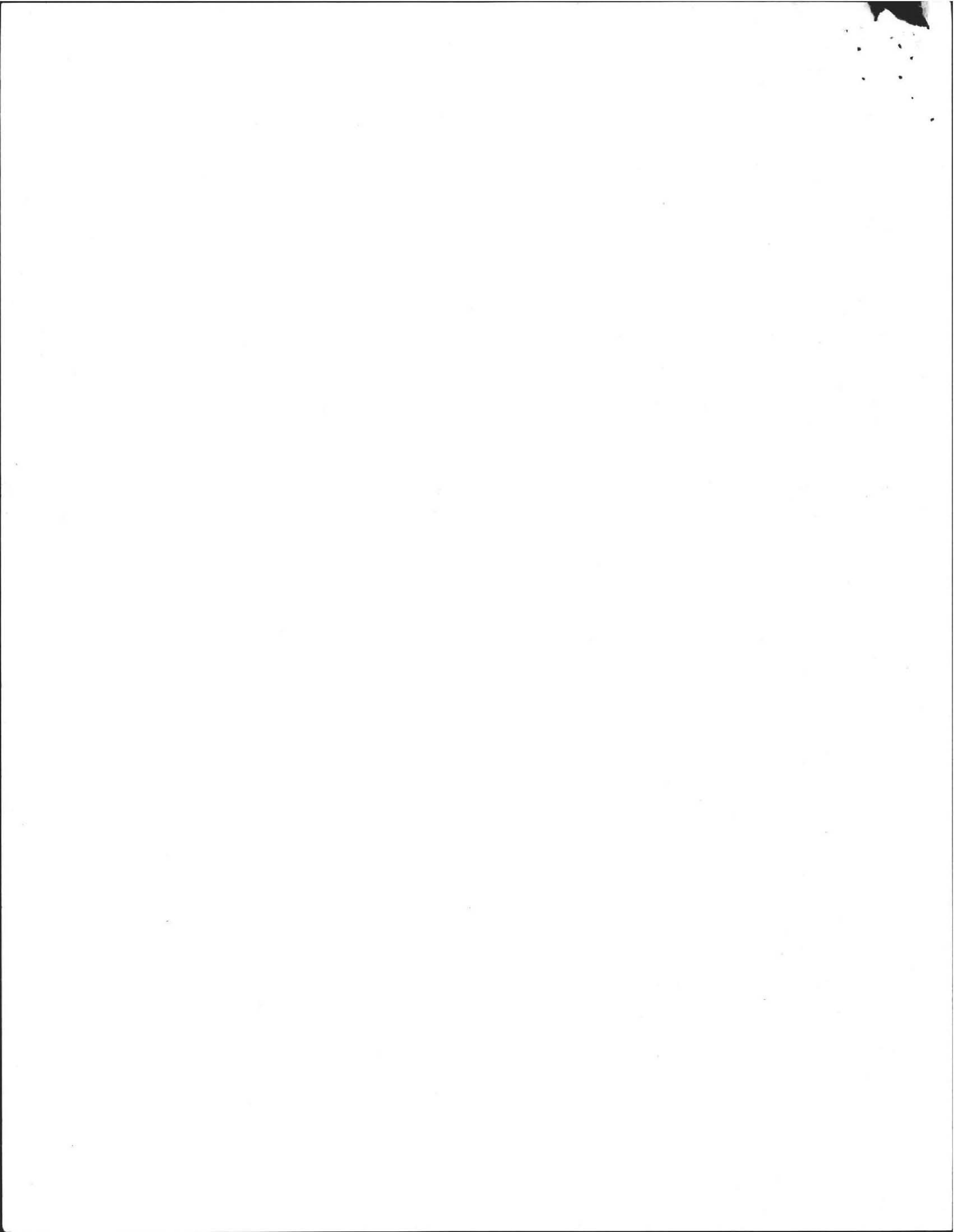

DEEP SOIL LOGS

OWNER STEVE CAHILLANE

DATE 5-9-88

LOCATION LOT 63
AMHERST WOODS

OBSERVER FILIOS Enterprises Inc.

B of H DENNIS PINSKI

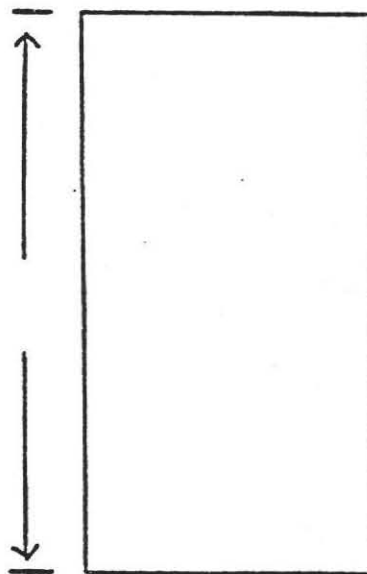
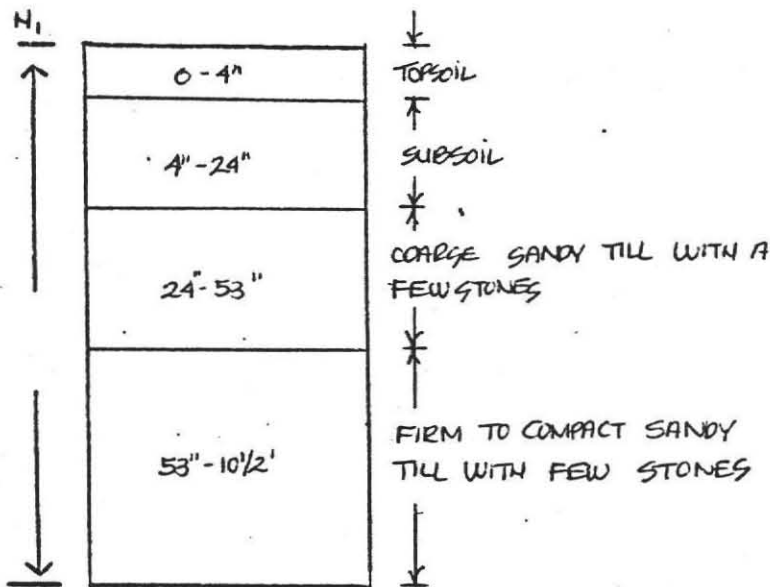

GROUND WATER SEEPAGE AT 130"

GROUND WATER _____

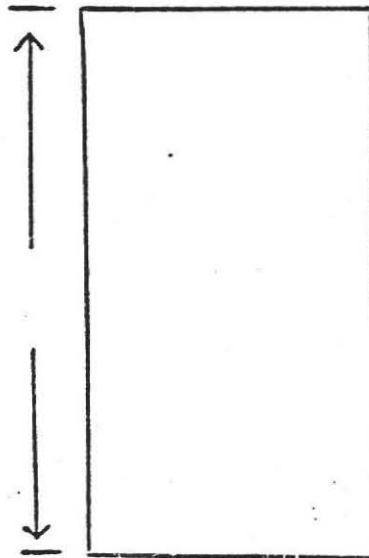
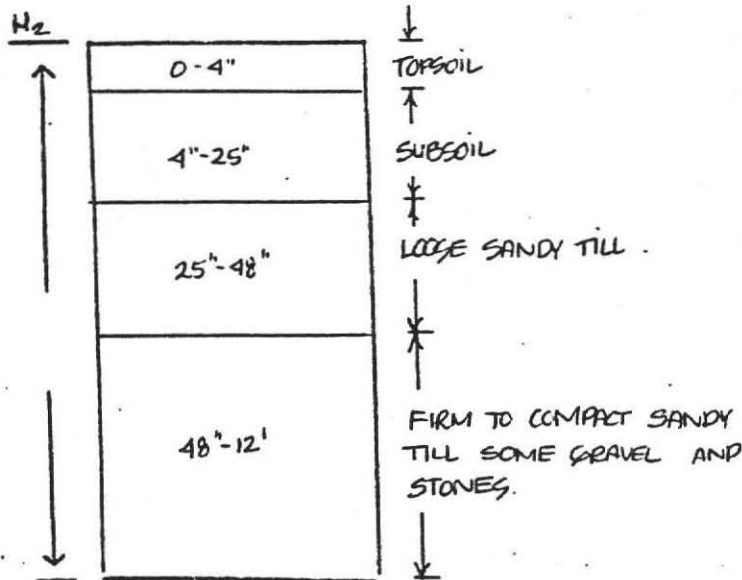

GROUND WATER _____

GROUND WATER _____

HOLE 1:
PERCOLATION RATE AT 48'

HOLE 2:
48"
3 min/inch

3 min./inch

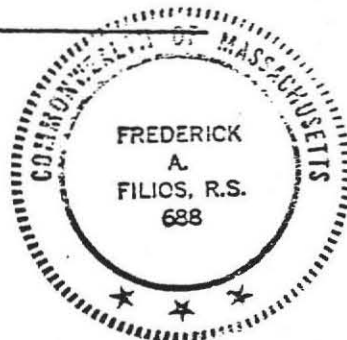

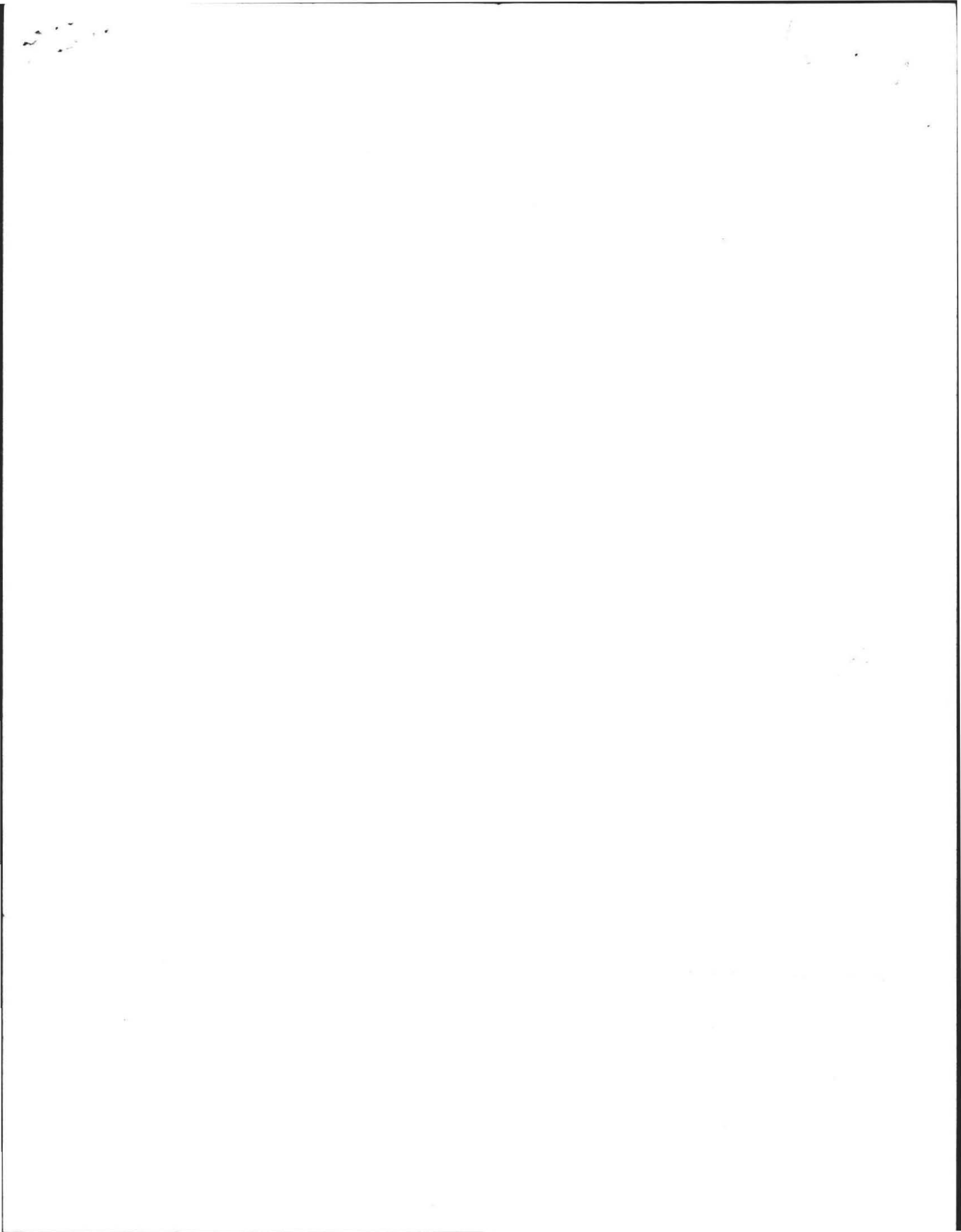

Town of



AMHERST Massachusetts

Bettye Anderson Frederic, Director

AMHERST HEALTH DEPARTMENT
70 BOLTWOOD WALK
AMHERST, MA 01002-2128
(413) 253-7077

June 23, 1988

C & C Contractors
P.O. Box 532
Leeds, MA 01053

88-25 fill

Dear Steve,

The disposal works construction permit for Lot #63, Amherst Woods has been issued by this office subject to the following conditions:

1. the designer to certify in writing that the sewage disposal system has been installed in accordance with the terms of the permit and the approved plan (State Environmental Code, Title V reg. 15.02(8)).
2. the leaching system is to be constructed in fill material as specified in the revised plan received by this office (plan section entitled "Cross-section of leach pits at A-A').

Please contact this office if you have any questions relative to this matter.

Sincerely,

Dennis A. Pinski, C.H.O., R.S.
Sanitarian

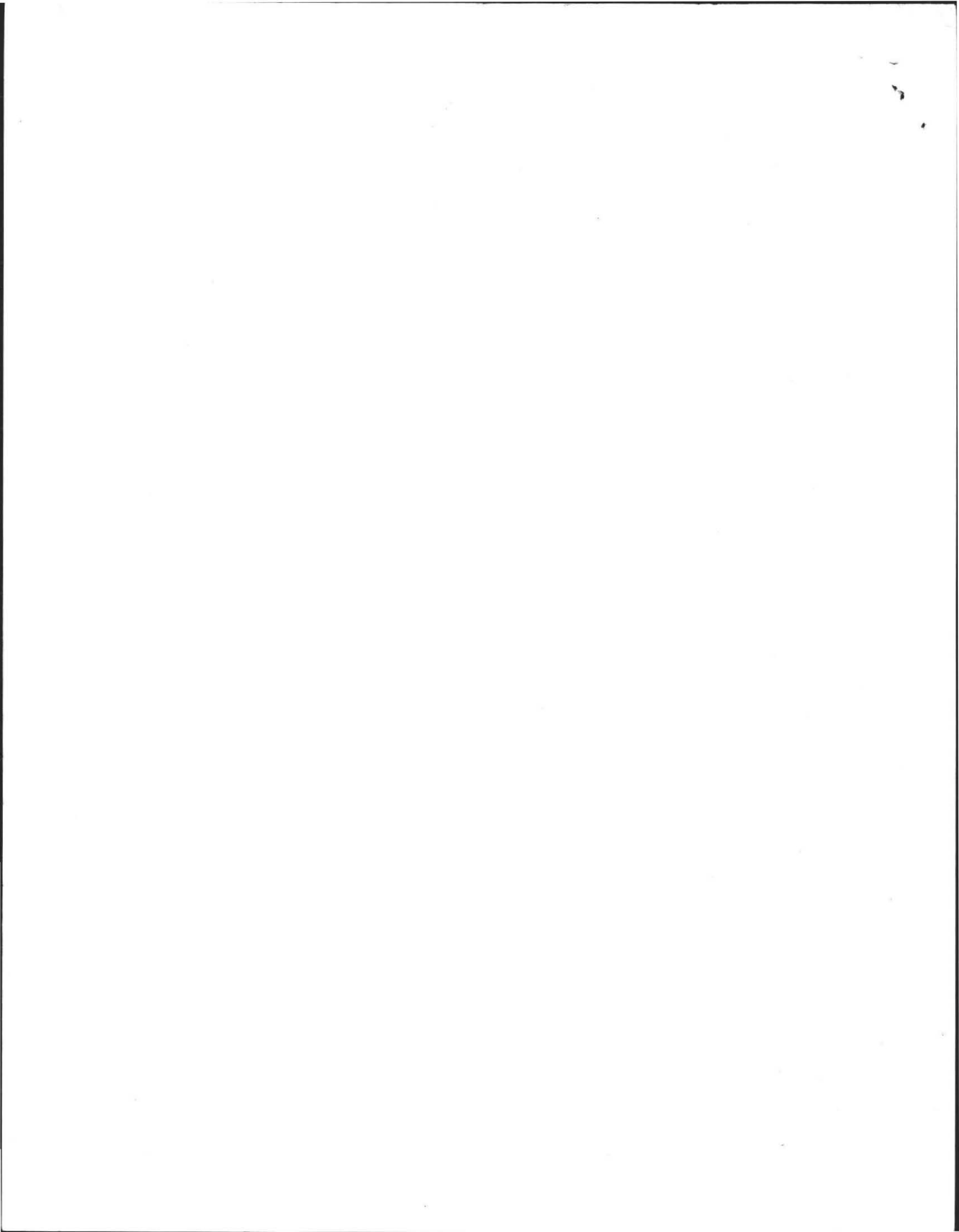

PROFILE OF TOP (UPPER MOST) LEACH PIT
 STEVEN CAHILLANE, C+C CONTRACTORS, LEEDS, MASS.
 SITE: LOT 63, AMHERST WOODS, AMHERST, MASS.

Prepared By: Filios Enterprises Inc., 69 Pelham Rd. Amherst, Mass.

Scale: Horizontal 1"=10', Vertical 1"=3'

June 8, 1988 Rev. 6/16/88

