

No. 85-38

#32

FEE #90  
#220

THE COMMONWEALTH OF MASSACHUSETTS

BOARD OF HEALTH

Town OF Amherst

Application for Disposal Works Construction Permit

Application is hereby made for a Permit to Construct (X) or Repair ( ) an Individual Sewage Disposal System at:

32 TRILLIUM WAY - Amherst MA 01002  
ANN PICROWAY - Location - Address  
KILLARA CONVT 45-206 Willow St. Springfield  
A. L. BRISTOL & SONS - Owner  
S. KADLEY - Address  
Installer

Type of Building  
Dwelling - No. of Bedrooms 4 Expansion Attic ( ) Garbage Grinder (YES)  
Other - Type of Building No. of persons Showers ( ) - Cafeteria ( )  
Other fixtures

Design Flow 5.5 gallons per person per day. Total daily flow 440 x 1.5 = 660 gallons.  
Septic Tank - Liquid capacity 1500 gallons Length 10 Width 5 Diameter 5 Depth 5  
Disposal Trench - No. 3 Width 2 Total Length 135 Total leaching area 4055 sq. ft.  
Seepage Pit No. Diameter Depth below inlet Total leaching area 270 sq. ft.

Other Distribution box (X) Dosing tank ( )  
Percolation Test Results Performed by F. A. FIDIAS Date 5/1/85  
Test Pit No. 1 8 minutes per inch Depth of Test Pit 10' Depth to ground water NONE AT 10'  
Test Pit No. 2 minutes per inch Depth of Test Pit Depth to ground water

Description of Soil

Nature of Repairs or Alterations - Answer when applicable

Agreement:  
The undersigned agrees to install the aforescribed Individual Sewage Disposal System in accordance with the provisions of TITLE 5 of the State Sanitary Code - The undersigned further agrees not to place the system in operation until a Certificate of Compliance has been issued by the board of health.

Application Approved By [Signature] Date 9/19/85  
Application Disapproved for the following reasons:

Permit No. 85-38 Issued 9/19/85 Date

THE COMMONWEALTH OF MASSACHUSETTS

BOARD OF HEALTH

OF

Certificate of Compliance

THIS IS TO CERTIFY, That the Individual Sewage Disposal System constructed ( ) or Repaired ( ) by

at  
has been installed in accordance with the provisions of TITLE 5 of The State Sanitary Code as described in the application for Disposal Works Construction Permit No. dated

THE ISSUANCE OF THIS CERTIFICATE SHALL NOT BE CONSTRUED AS A GUARANTEE THAT THE SYSTEM WILL FUNCTION SATISFACTORY.

DATE Inspector

THE COMMONWEALTH OF MASSACHUSETTS

BOARD OF HEALTH

OF

Town OF Amherst

Disposal Works Construction Permit

Permission is hereby granted ANN PICROWAY -  
to Construct (X) or Repair ( ) an Individual Sewage Disposal System  
at No. 32 TRILLIUM WAY - Street

as shown on the application for Disposal Works Construction Permit No. 85-38 Dated 9/19/85  
[Signature] Board of Health

DATE 9/19/85

CHECK OR FILL IN WHERE APPLICABLE

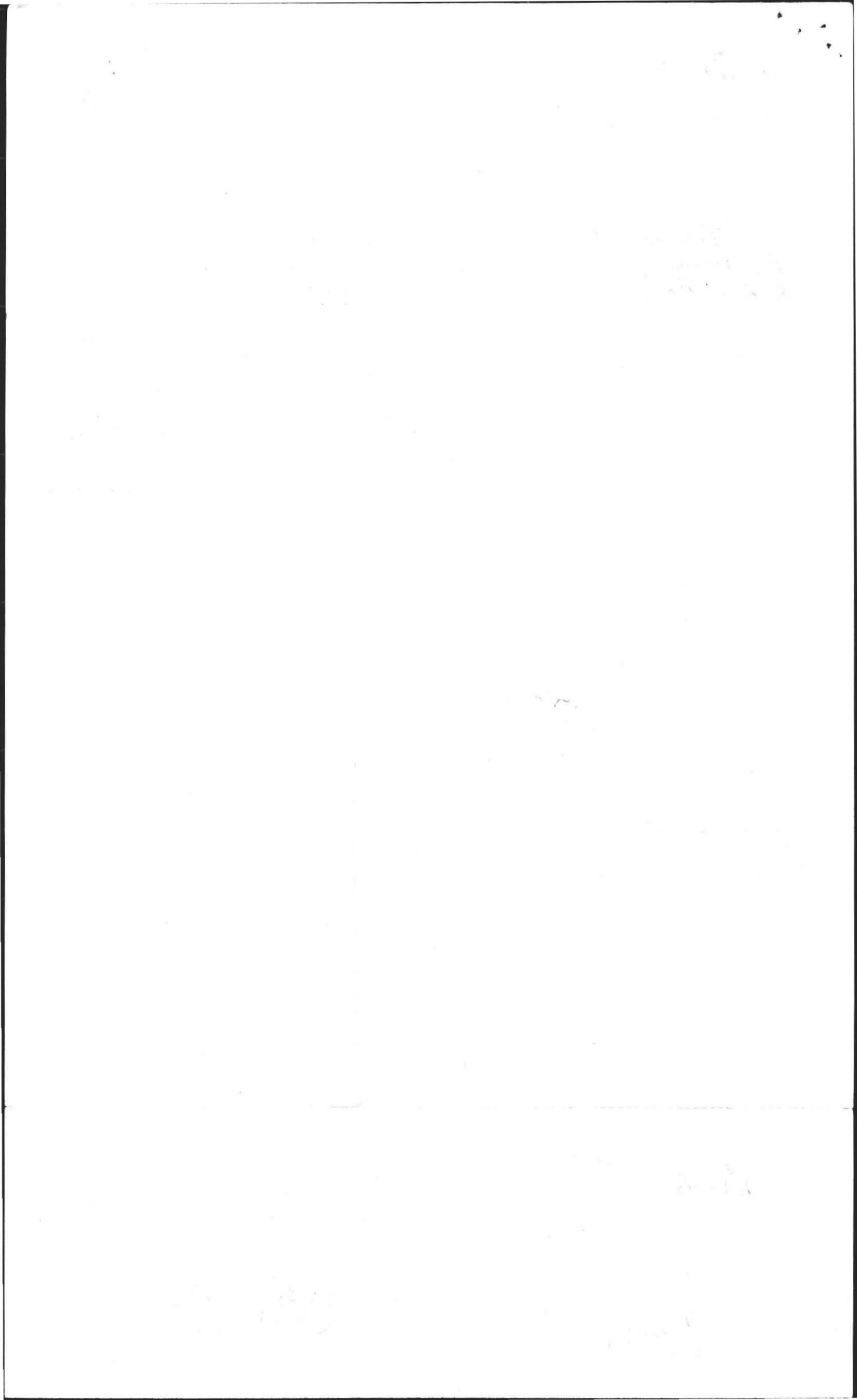

DEEP SOIL LOGS

OWNER Amherst Woods Inc.

DATE May 1, 1985

LOCATION Amherst Woods  
Lot # 66

OBSERVER F.A. Filios

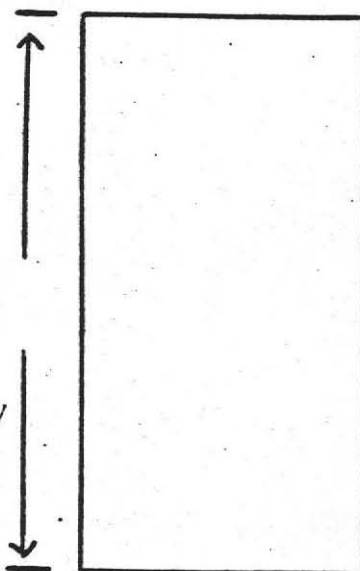
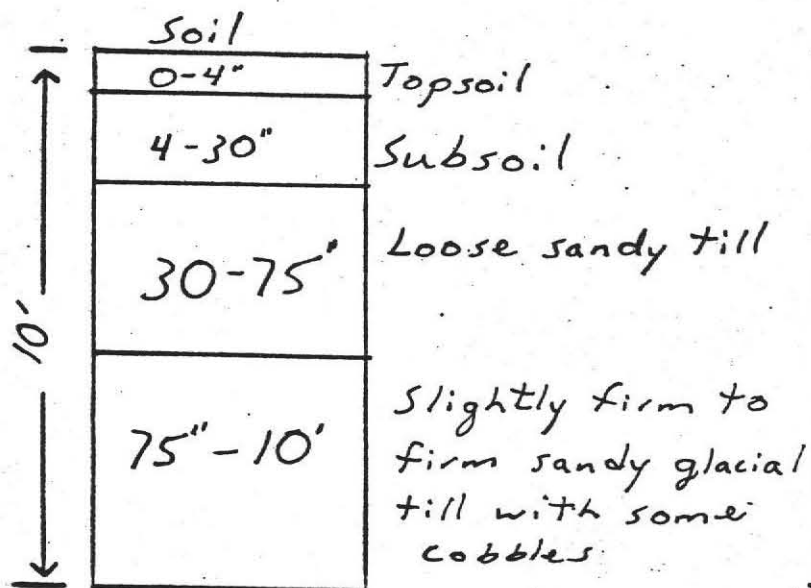

GROUND WATER 10'

GROUND WATER \_\_\_\_\_

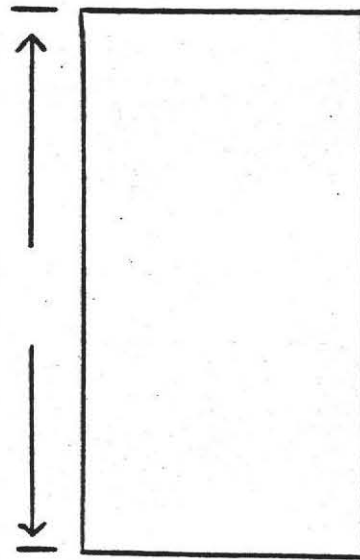
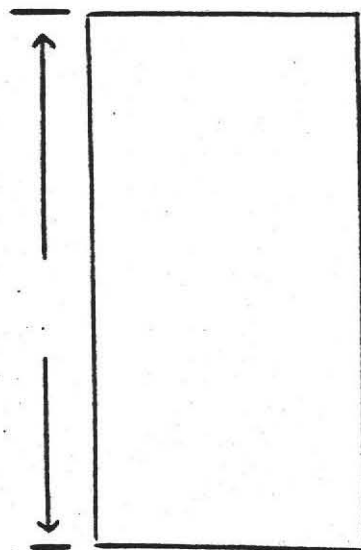

GROUND WATER \_\_\_\_\_

GROUND WATER \_\_\_\_\_

Percolation Rate at 36":

8 min/inch

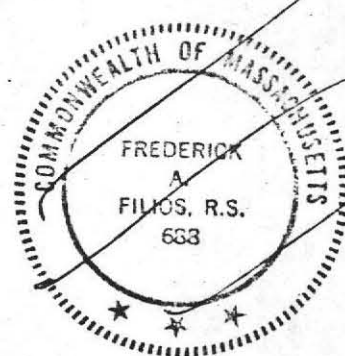

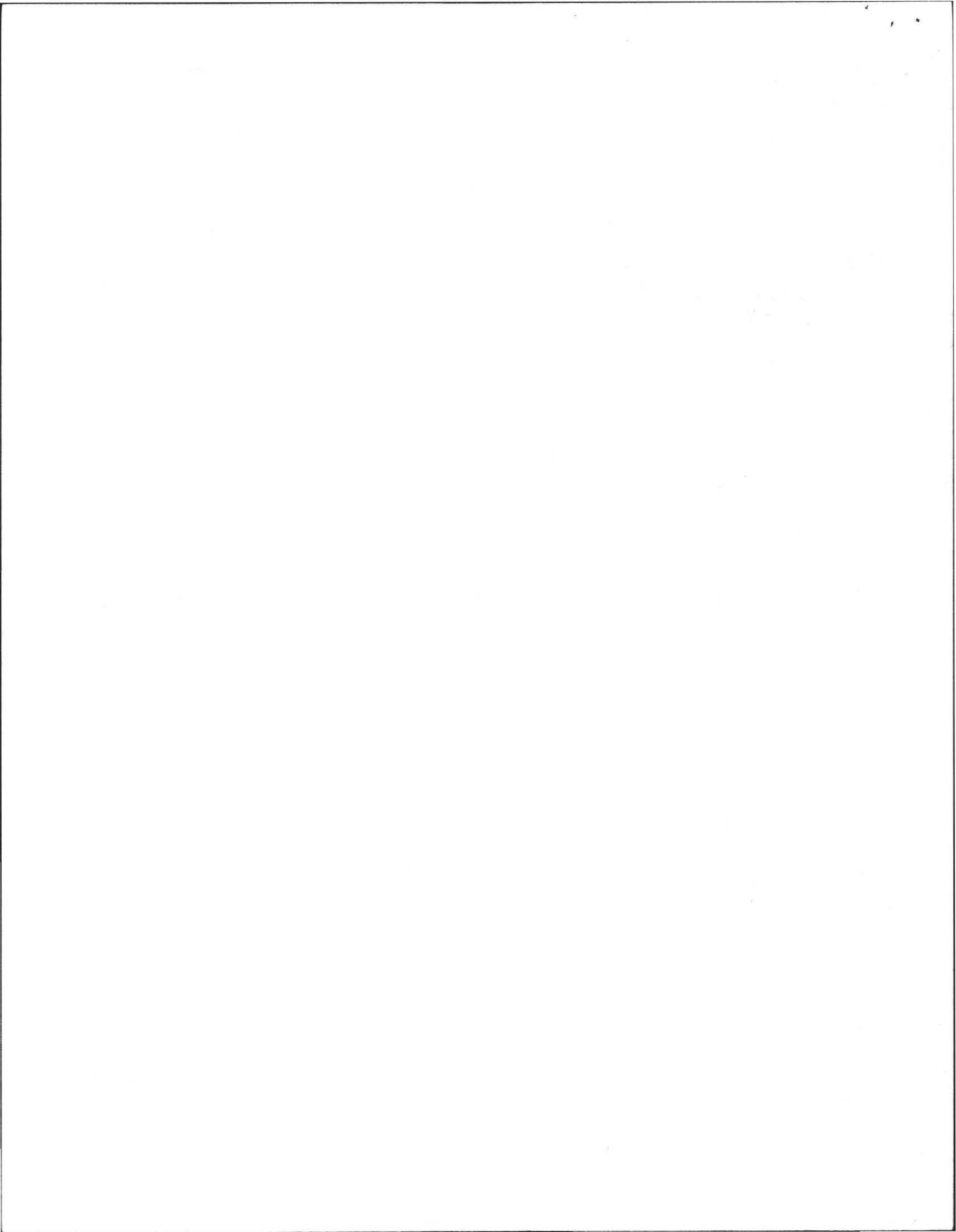

# PERCOLATION TEST LOCATION

For: Amherst Woods Inc.  
4413 Pine St.  
Philadelphia, PA.

Scale: 1" = 40'

By: F.A. Filios

At: Amherst Woods  
Amherst, MA.  
Lot # 66

May 1985

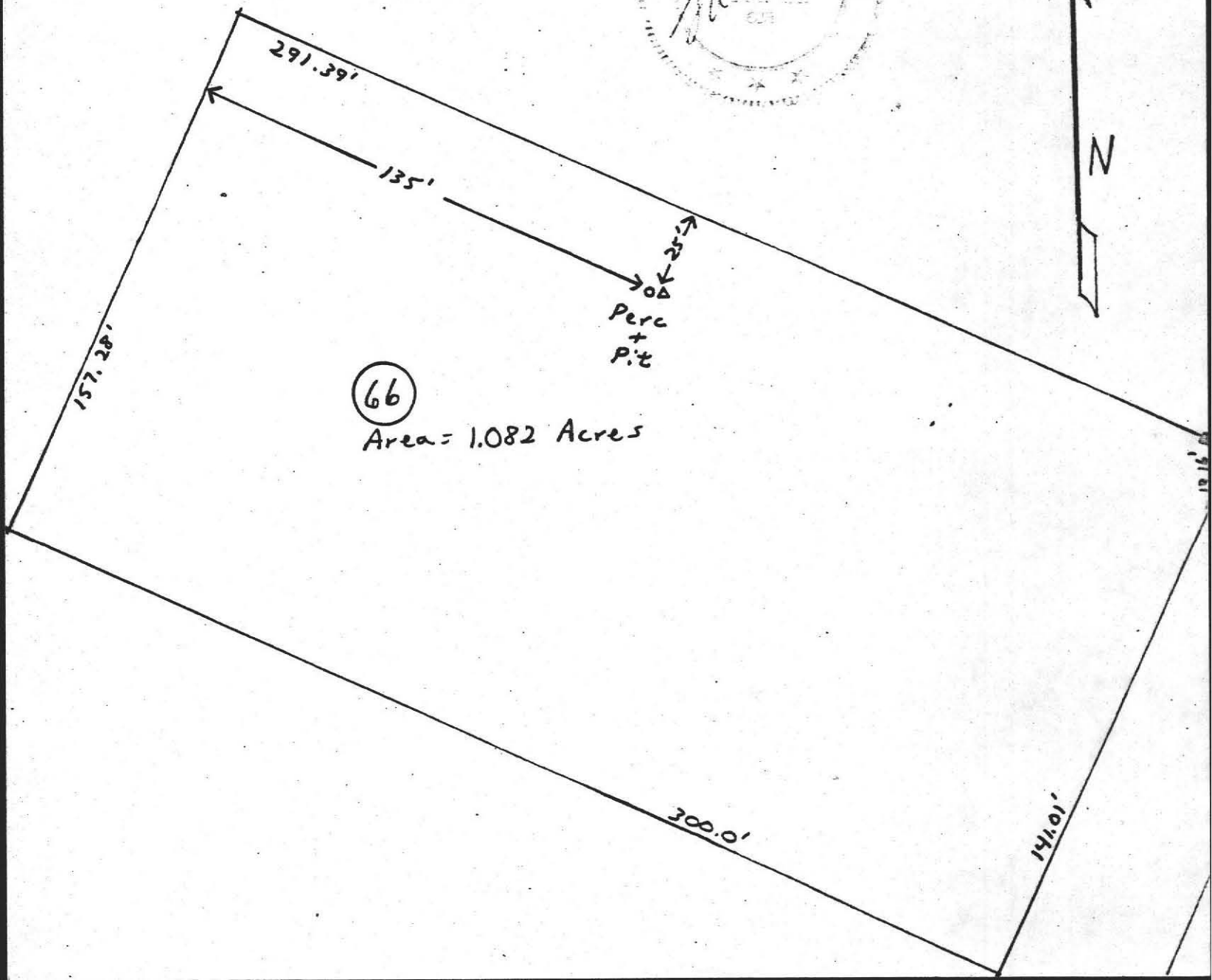

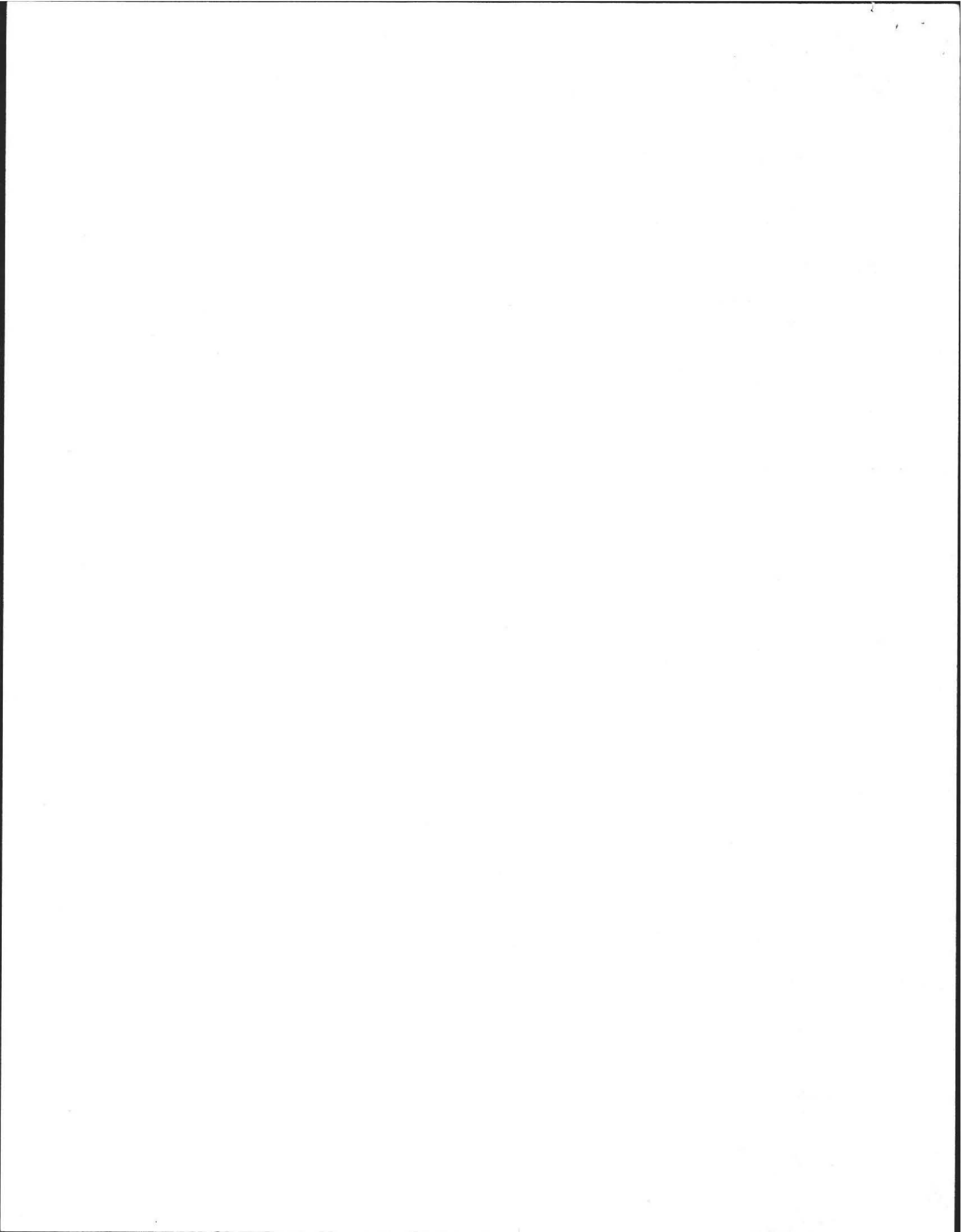

# PLAN SHOWING SEWAGE DISPOSAL

For: Ann Pieroway  
 Killara Construction  
 45-206 Willow Street  
 Springfield, MA. 01103

At: Lot 66  
 Amherst Woods  
 Amherst, MA.  
 By: F.A. Filios, R.S.  
 69 Pelham Road  
 Amherst, MA.

Scale: 1"=40'  
 Sept. 9, 1985

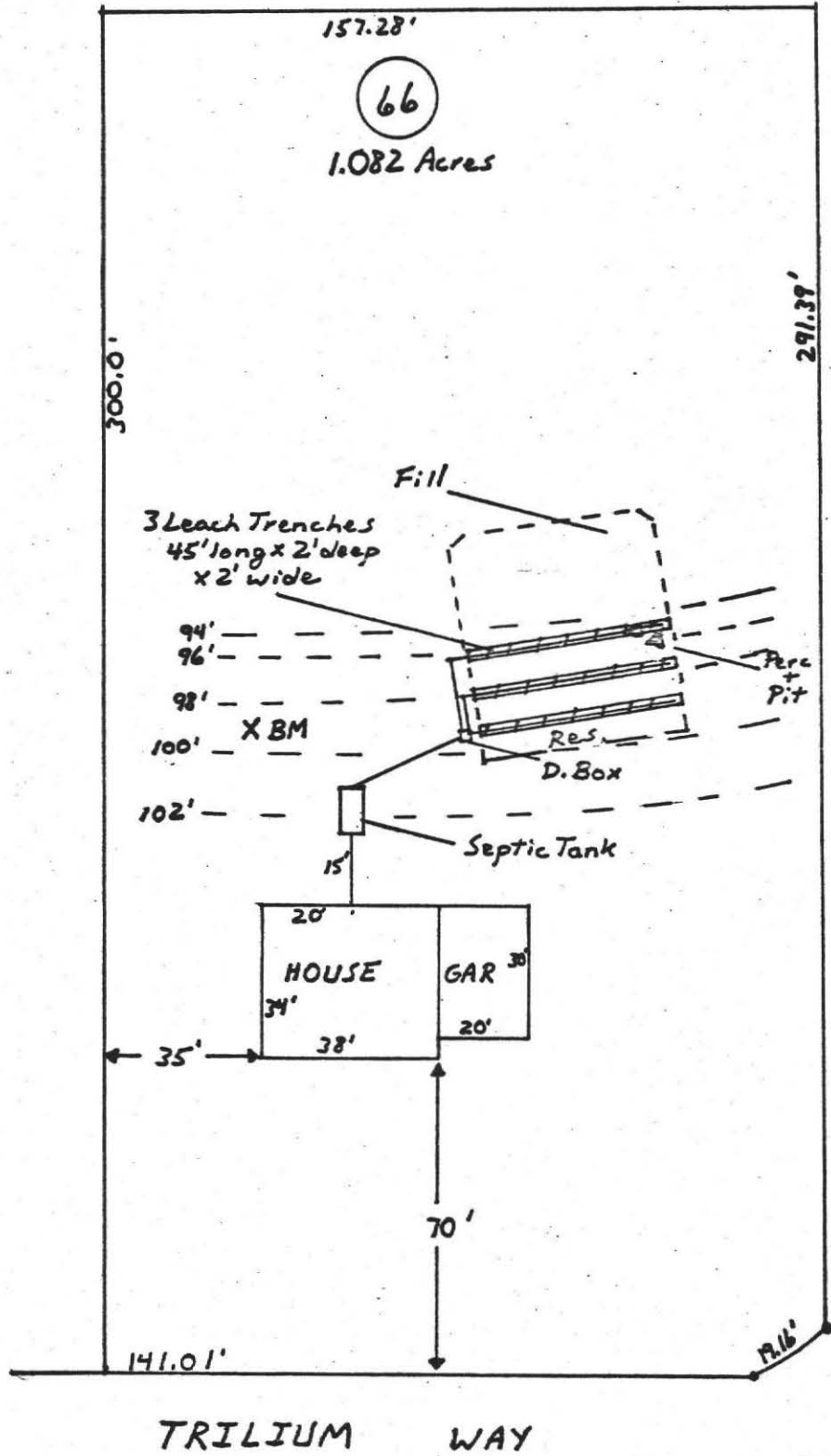

Note: On Town Water  
 no wells within  
 200' of leach.

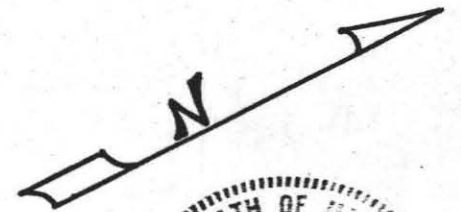

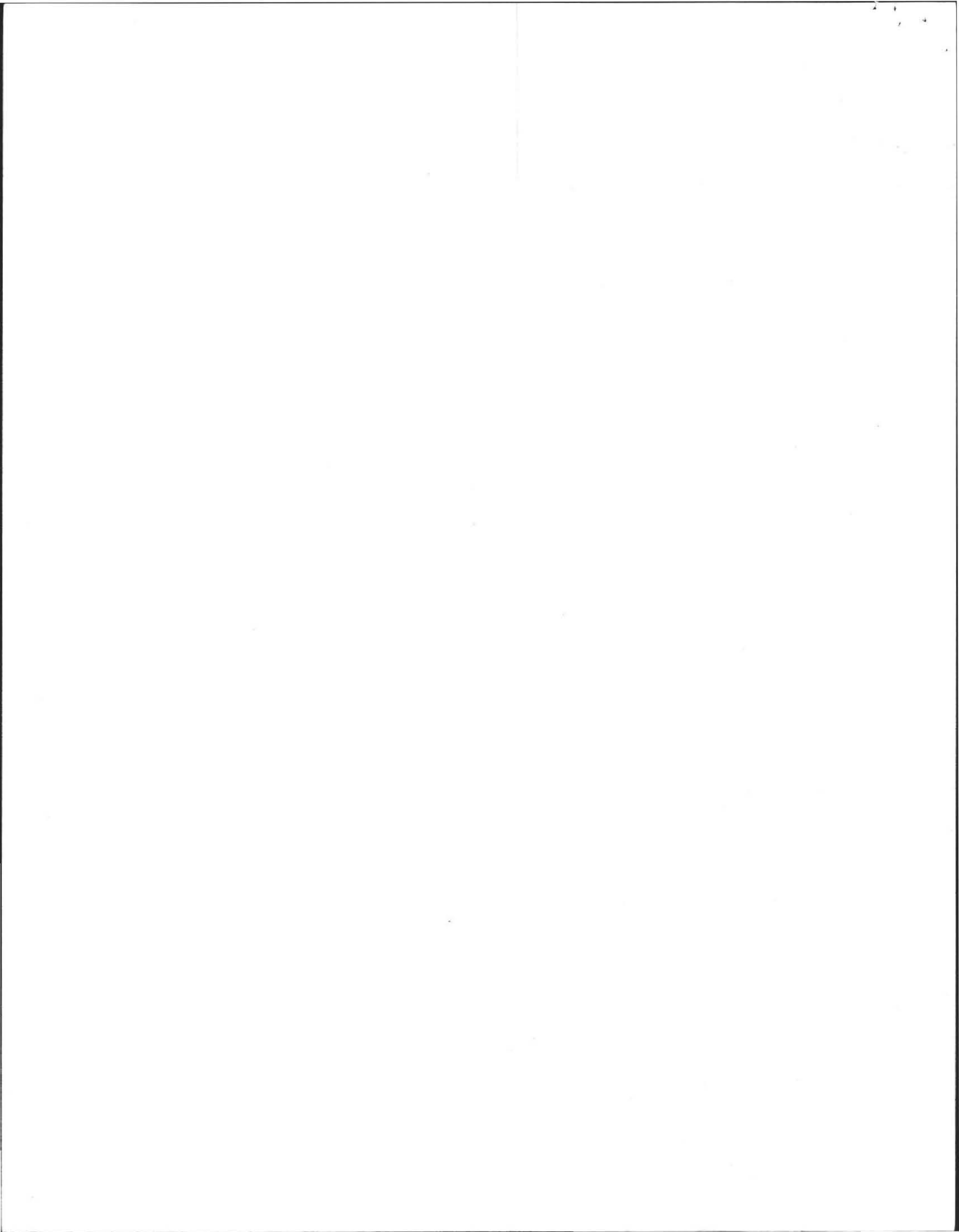



# PROFILE OF SEPTIC SYSTEM

R. Ann Pieroway / Killara Construction  
 45-206 Willow St. Springfield, MA. 01103  
 E. Lot 66 Trilium Way Amherst Woods  
 Amherst, MA.

BY: Frederick A. Filios, W.T.  
 69 Pelham Road  
 Amherst, MA  
 01002

DATE: September 9, 1985  
 SCALE: Horizontal: 1" = 10'  
 Vertical: 1" = 3'

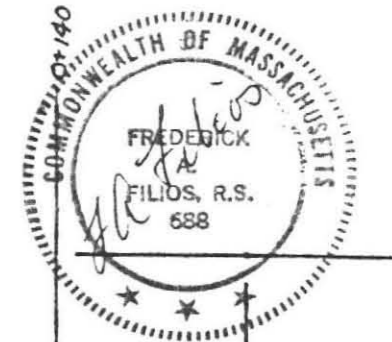
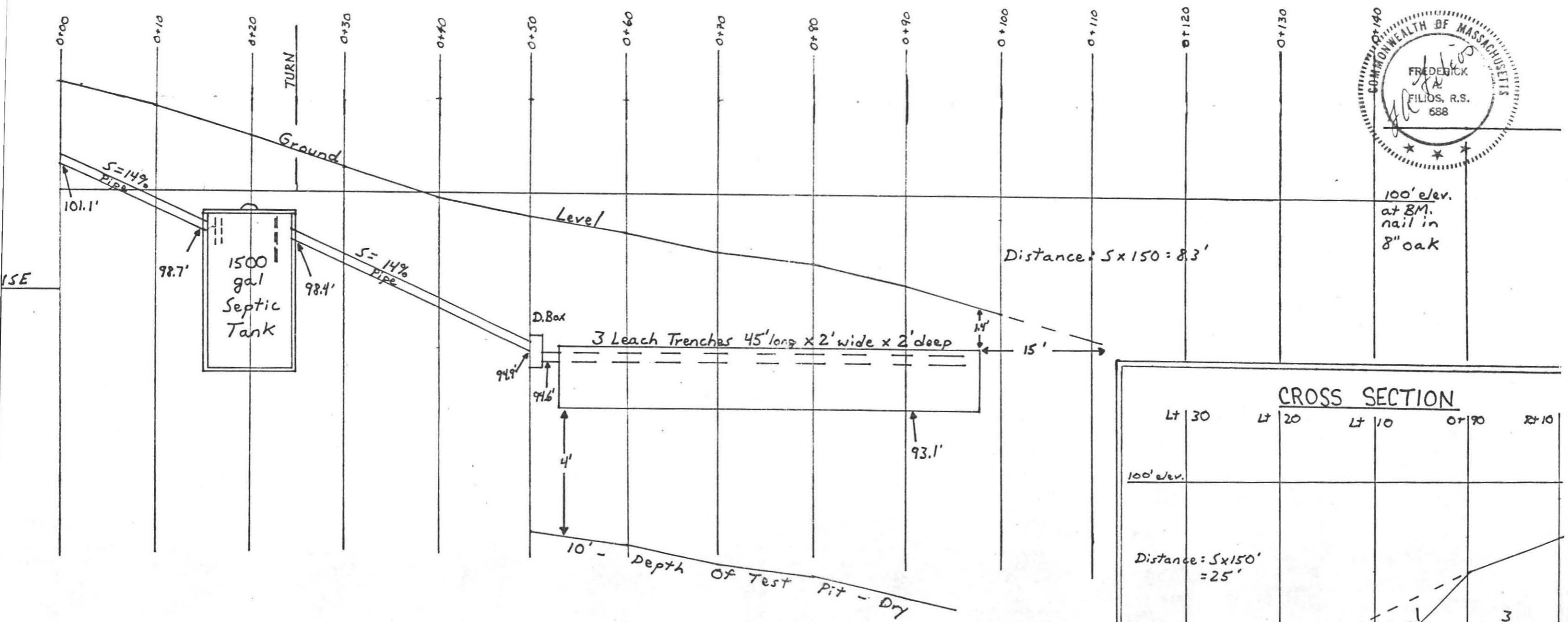

## SPECIFICATIONS

ALL MATERIALS AND CONSTRUCTION WILL BE IN ACCORDANCE WITH COMM. OF MASS. D.E.Q.E. STATE ENVIRONMENTAL CODE TITLE 5.

## CALCULATIONS

4 Balm x 110 = 440 gal.  
 G.G. add 50% = 220 gal.  
 Total = 660 gal req.  
 Rate: 8 min/inch for 3 trenches 45' long:  
 Sides: 3 x 45' long x 1.5' deep x 2 sides x Rate of 1.25 = 506.25  
 Bottom: 3 x 45' long x 2' wide x Rate of .63 = 170.1  
 Total = 676.35 gal.

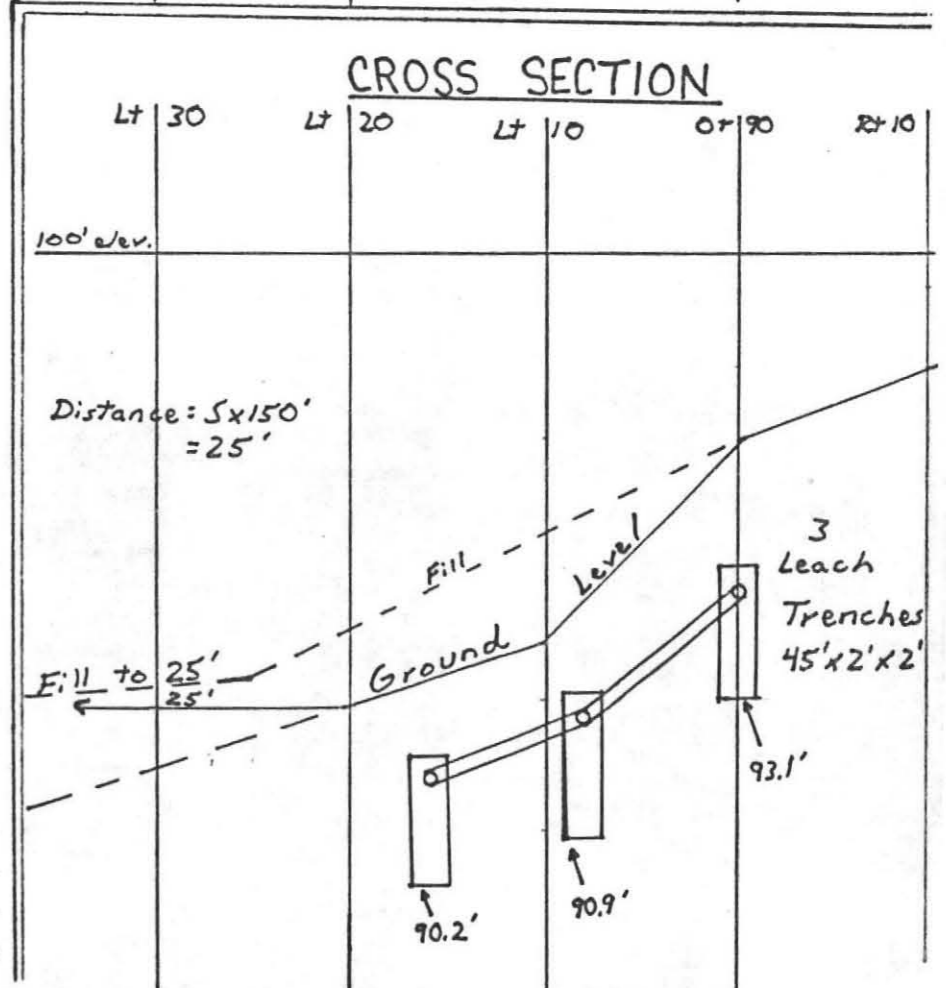

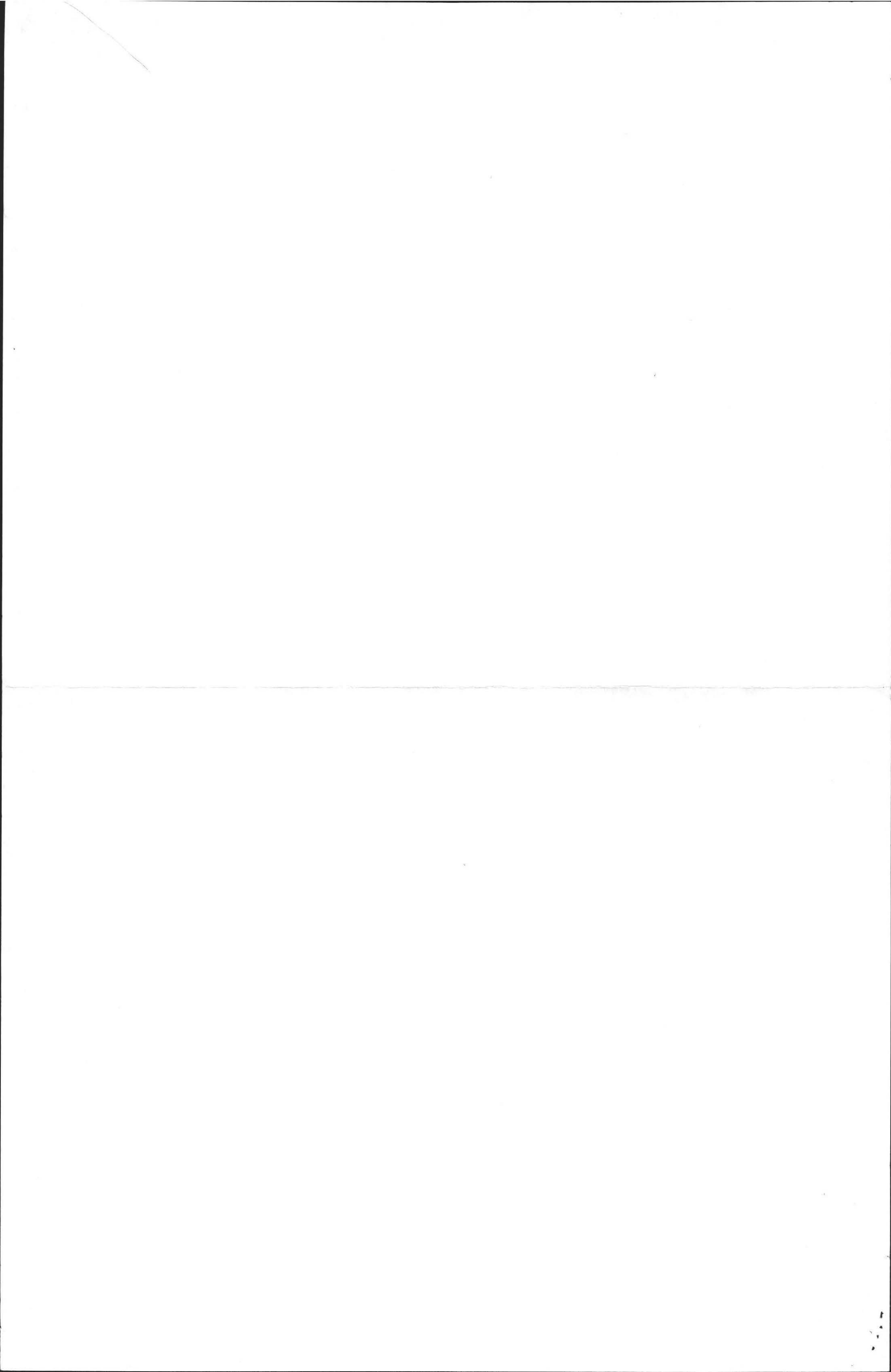

BOARD OF HEALTH

TOWN OF AMHERST, MASSACHUSETTS

Lot #66 TRILLIUM WAY

Important Information Regarding Your Private Sewage Disposal System

DISPLAY THIS DOCUMENT IN A PROMINENT PLACE

Owner ANN PIEROWAY <sup>KILLARA CONST</sup> Address 45-206 WILLOW ST - SPFLD MA.

Installer A. L. BRISTOL Address 50 HADLEY MA.

Date Installation Inspected and Approved 12-18-85

Description of System: Tank Capacity: 1500

Leach Field (X) Bed ( ) Seepage Pit ( ) Square Feet: 270 BOTTOM  
405 SIDES

Garbage Grinder Yes (X) No ( ) No. Bedrooms: 4 No. People 8

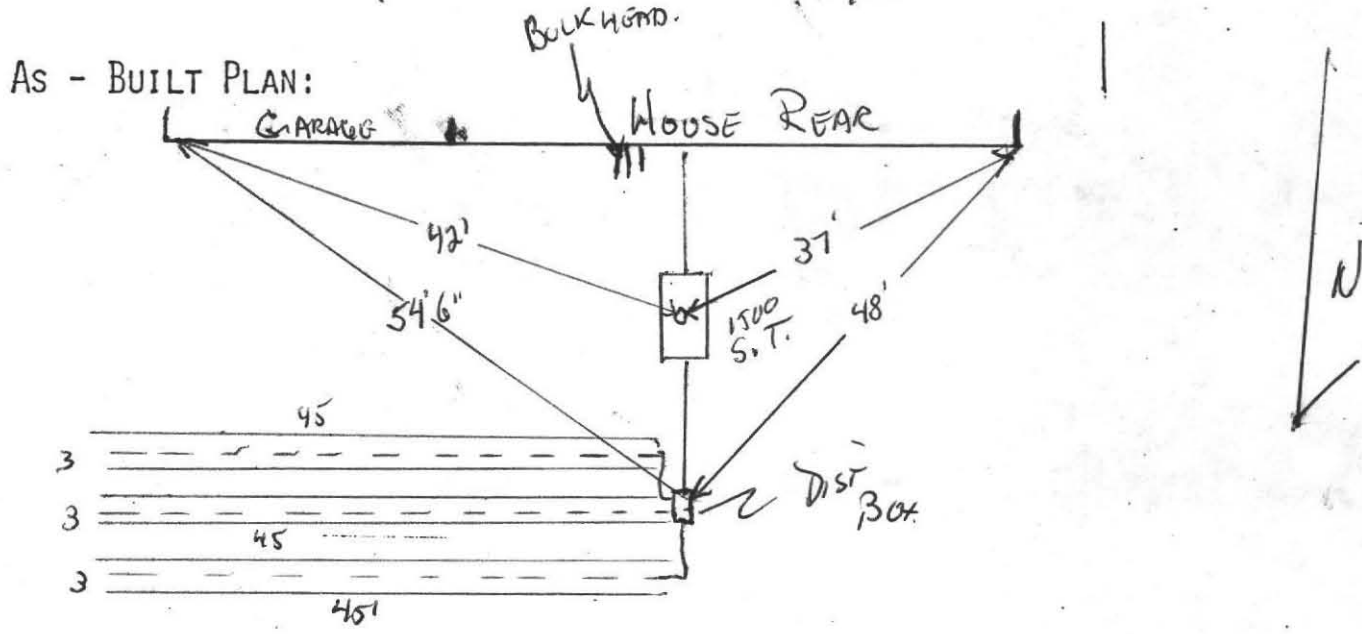

PROPER MAINTENANCE OF YOUR PRIVATE SEWAGE DISPOSAL SYSTEM

1. This system must be inspected periodically and the tank pumped out at an interval not to exceed 3 years.
2. For your protection sanitary pumpers are licensed by the Amherst Board of Health.
3. Regular pumping is crucial to avoid early failure and costly repairs of the system.
4. DO NOT dispose into the system such items as rags, string, sanitary napkins, coffee grounds as they can cause it to clog and fail.
5. Further information can be obtained by contacting your Health Department at 253-7077.

