

SOUTHEAST STREET 87-27

pending

1680

No. 87-27

THE COMMONWEALTH OF MASSACHUSETTS

BOARD OF HEALTH

Town Amherst OF

Application for Disposal Works Construction Permit



Application is hereby made for a Permit to Construct () or Repair (X) an Individual Sewage Disposal System at:

1680 Southeast St.
Location - Address
Charles Thompson
Owner
1680 South east St. Amherst, MA
or Lot No. Address

Type of Building
Dwelling — No. of Bedrooms 4 Expansion Attic () Garbage Grinder (X)
Other — Type of Building _____ No. of persons _____ Showers () — Cafeteria ()
Other fixtures _____

Design Flow 55 gallons per person per day. Total daily flow 440 gallons.
Septic Tank — Liquid capacity 1000 gallons Length 8.5' Width 5' Diameter _____ Depth 5.33'
Disposal Trench — No. _____ Width 18' Total Length 25' Total leaching area 450 sq. ft. Bottom
Seepage Pit No. _____ Diameter _____ Depth below inlet _____ Total leaching area _____ sq. ft.
Other Distribution box (X) Dosing tank ()
Percolation Test Results Performed by Filius Enterprises, Inc. Date Oct. 16, 1987
Test Pit No. 1 2 minutes per inch Depth of Test Pit 7' Depth to ground water 70"
Test Pit No. 2 _____ minutes per inch Depth of Test Pit _____ Depth to ground water _____

Description of Soil Soil log attached

Nature of Repairs or Alterations — Answer when applicable _____

Agreement:

The undersigned agrees to install the aforescribed Individual Sewage Disposal System in accordance with the provisions of TITLE 5 of the State Sanitary Code — The undersigned further agrees not to place the system in operation until a Certificate of Compliance has been issued by the board of health.

Signed _____ Date _____

Application Approved By _____ Date _____

Application Disapproved for the following reasons: _____ Date _____

Permit No. _____ Issued _____ Date _____

THE COMMONWEALTH OF MASSACHUSETTS

BOARD OF HEALTH

Town Amherst OF

Certificate of Compliance

THIS IS TO CERTIFY, That the Individual Sewage Disposal System constructed () or Repaired (X) by _____

at 1680 South east St. Installer _____

has been installed in accordance with the provisions of TITLE 5 of The State Sanitary Code as described in the application for Disposal Works Construction Permit No. _____ dated _____

THE ISSUANCE OF THIS CERTIFICATE SHALL NOT BE CONSTRUED AS A GUARANTEE THAT THE SYSTEM WILL FUNCTION SATISFACTORY.

DATE _____ Inspector _____

CHECK OR FILL IN WHERE APPLICABLE

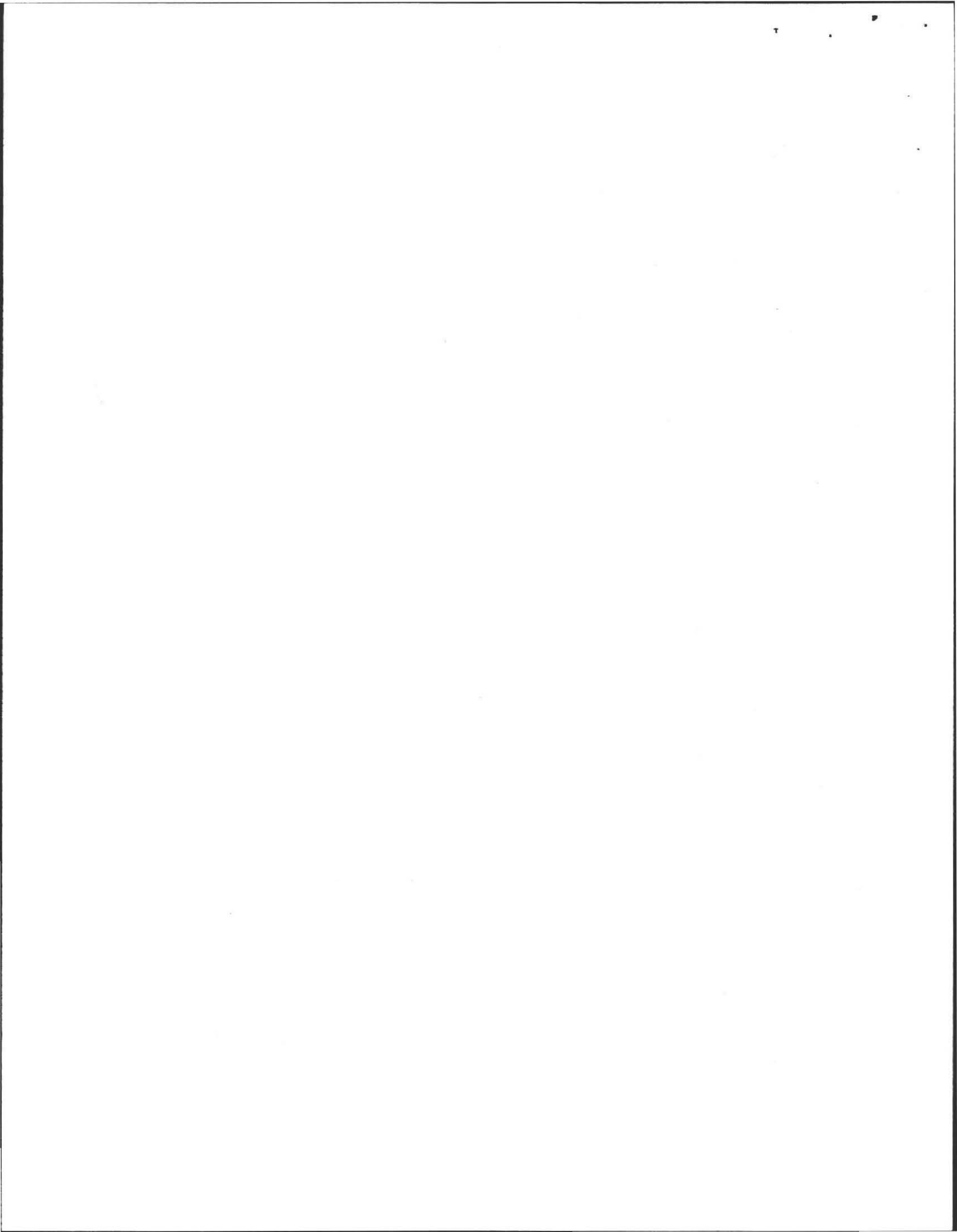

DEEP SOIL LOGS

OWNER CHARLES THOMPSON

DATE OCT. 16, 1987

LOCATION 1650 S. EAST ST.
AMHERST, MA

OBSERVER F. FILIOS

B of H Peter KOLODIEZ

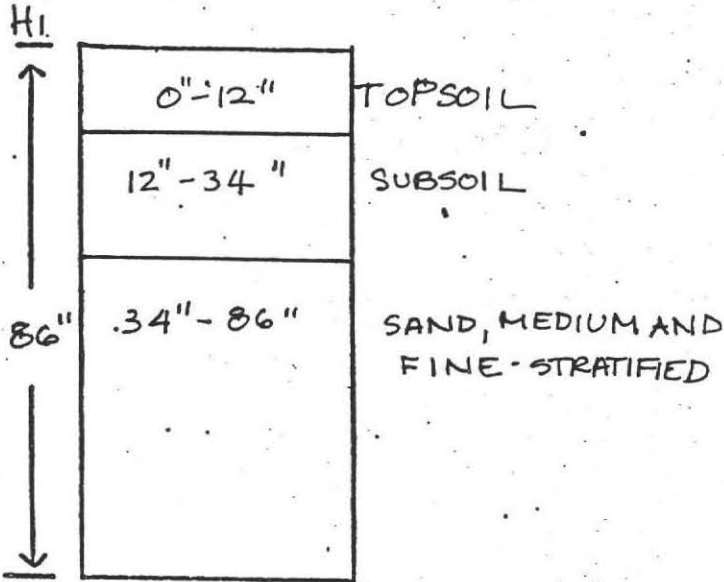

GROUND WATER 70"

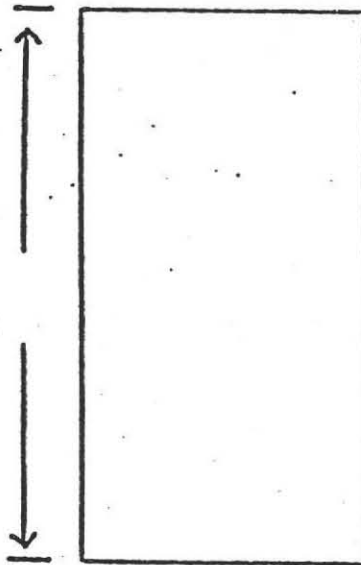

GROUND WATER _____

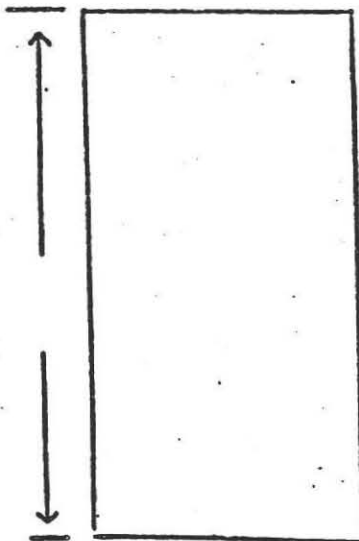

GROUND WATER _____

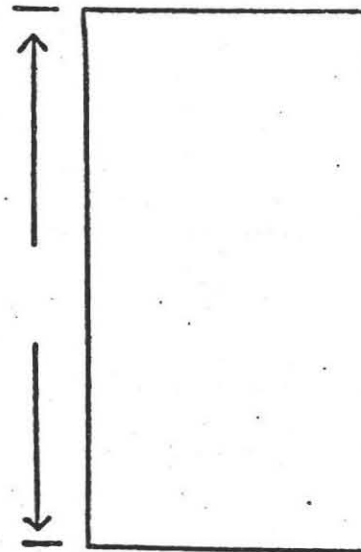

GROUND WATER _____

PERCOLATION RATE AT 55:

2 min./inch



Filios Enterprises Inc.

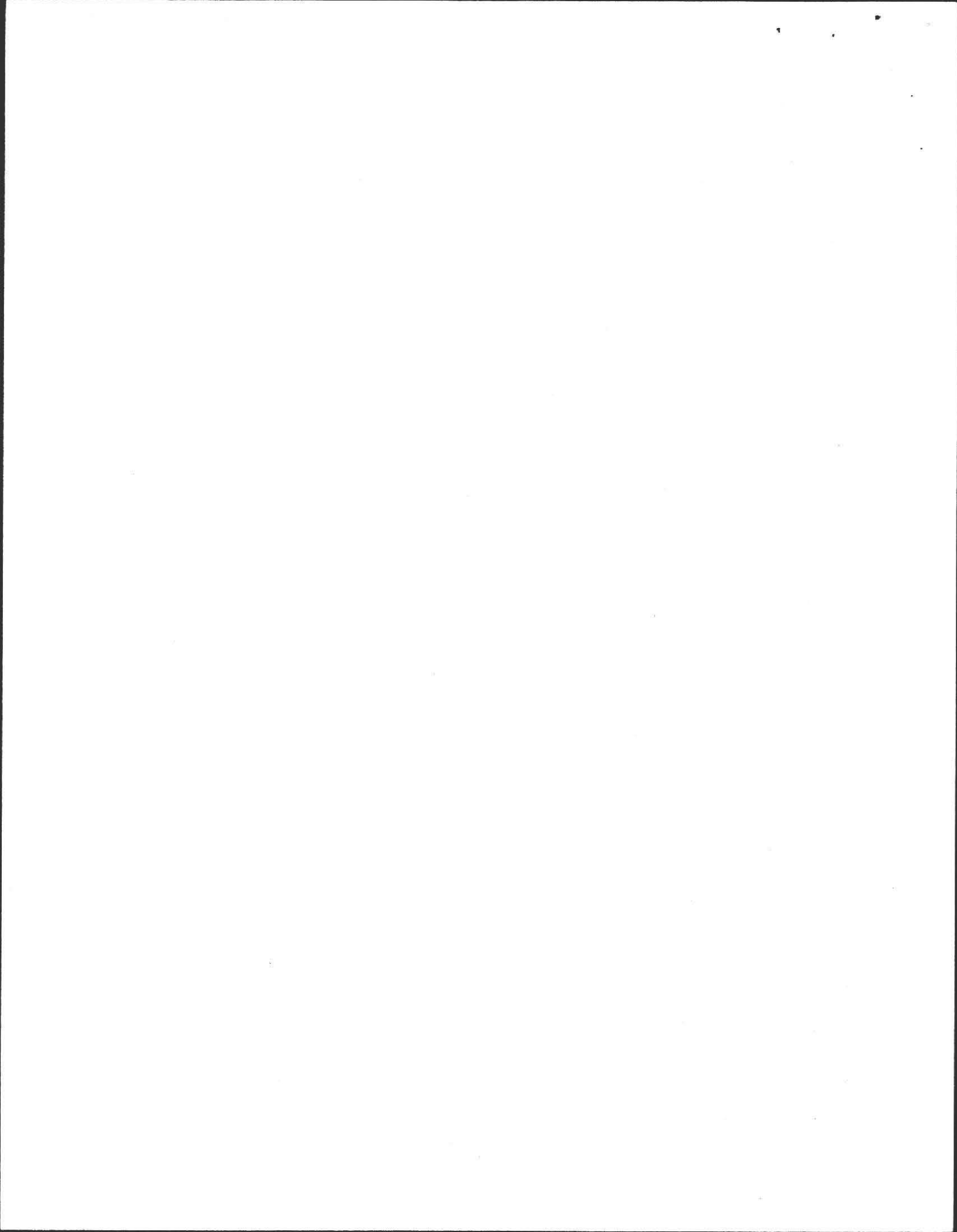

PLAN SHOWING SEWAGE DISPOSAL

For: Charles Thompson
 1680 South East St.
 Amherst, MA 01002

FILIOS ENTERPRISES INC.
 69 PELHAM RD.
 AMHERST, MA 01002

Date: 10.28.87
 Scale: 1" = 30'



L.Z.

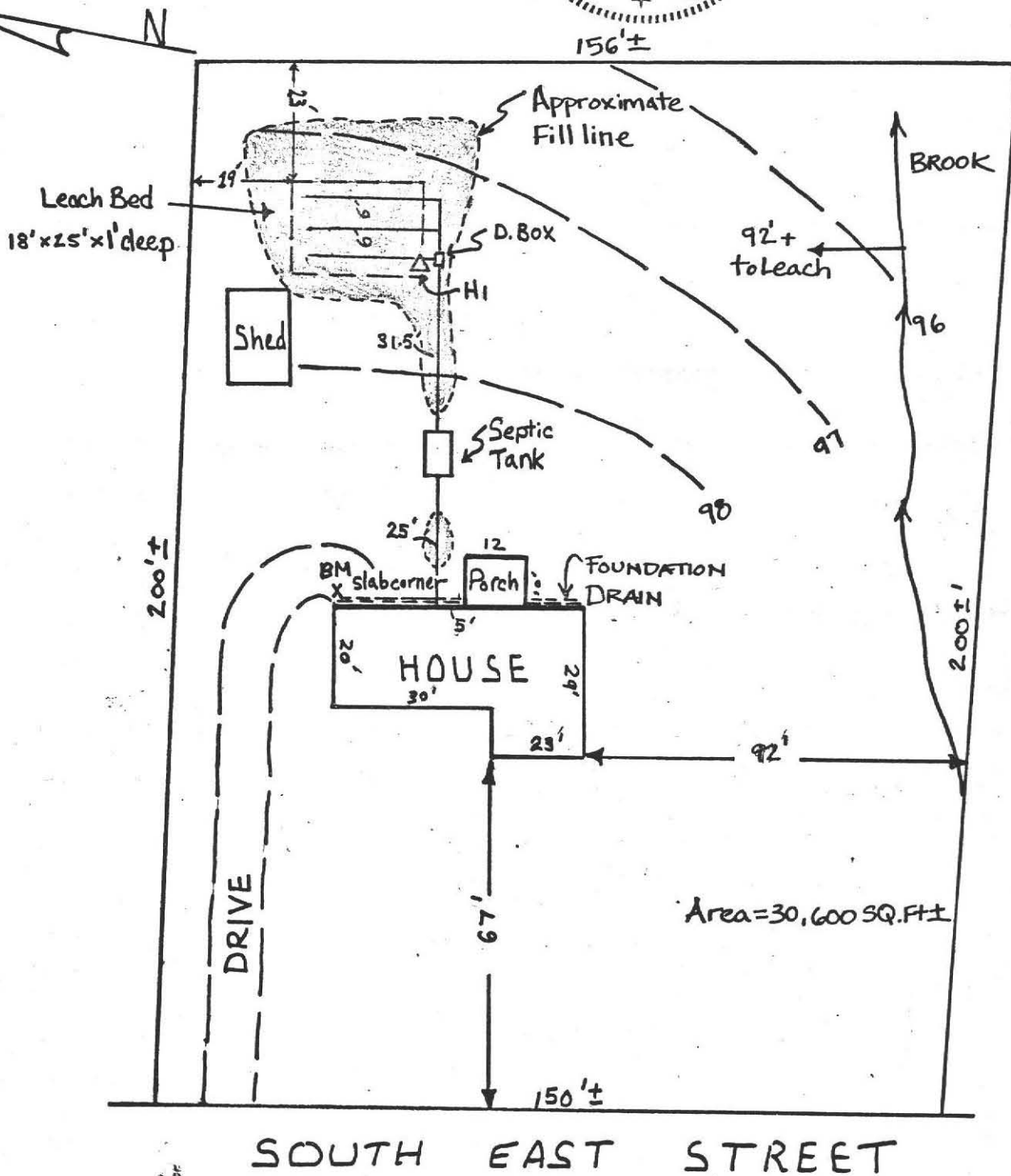

Note: TOWN WATER AVAILABLE

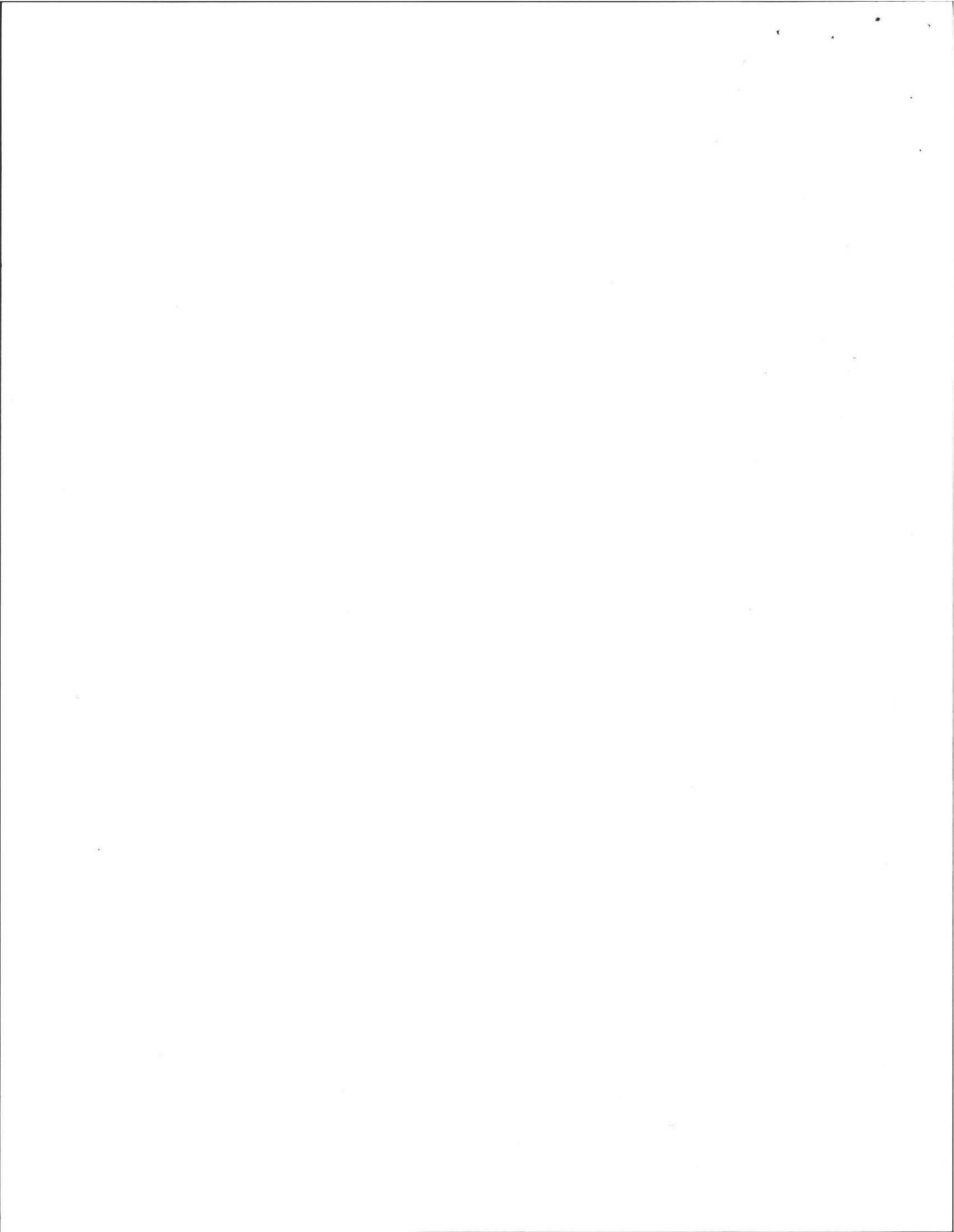

PROFILE OF SEPTIC SYSTEM

BY: FILIOS ENTERPRISES INC.
 69 PELHAM RD.
 AMHERST MA 01002
 I.Z.

DATE: 10.28.87
 SCALE: Horizontal 1" = 10'
 Vertical 1" = 3'

FOR: CHARLES THOMPSON
 SITE: 1680 SOUTHEAST ST.
 AMHERST, MA 01002

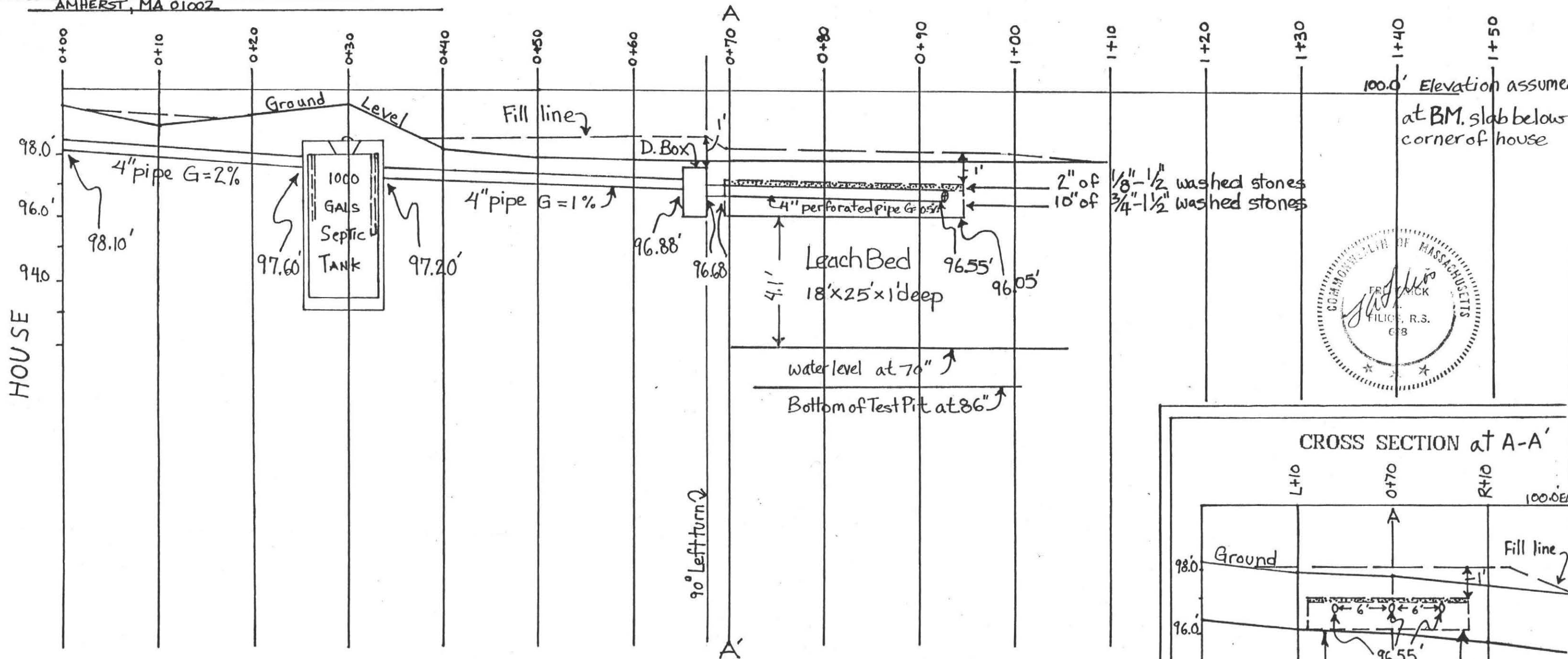

SPECIFICATIONS

All materials and construction will be in accordance with Commonwealth of MA D. E. Q. E. State Environmental Code Title 5.

CALCULATIONS

4 Bedroom @ 110 = 440 Gals/day Required
 Perc. Rate = 2 min./inch
 Leach Bed 18' x 25' x 1' deep
 Bottom area 18 x 25 = 450 SQ. FT.
 450 x 1.0 = 450 Gals/day Available

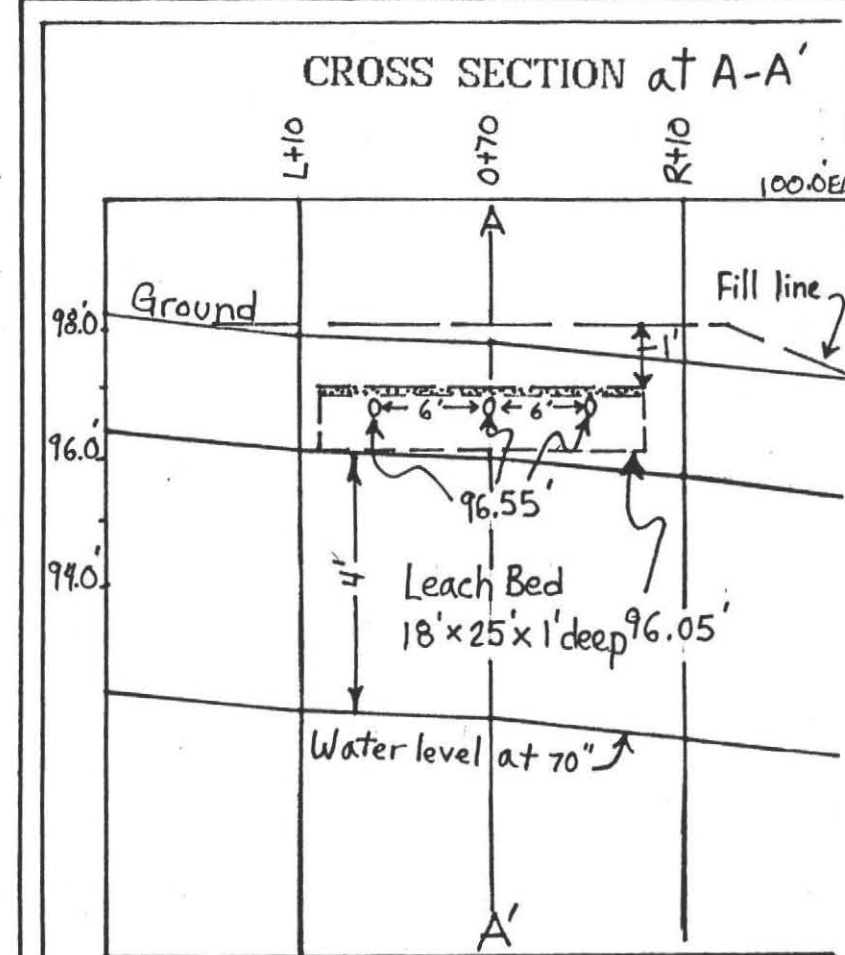

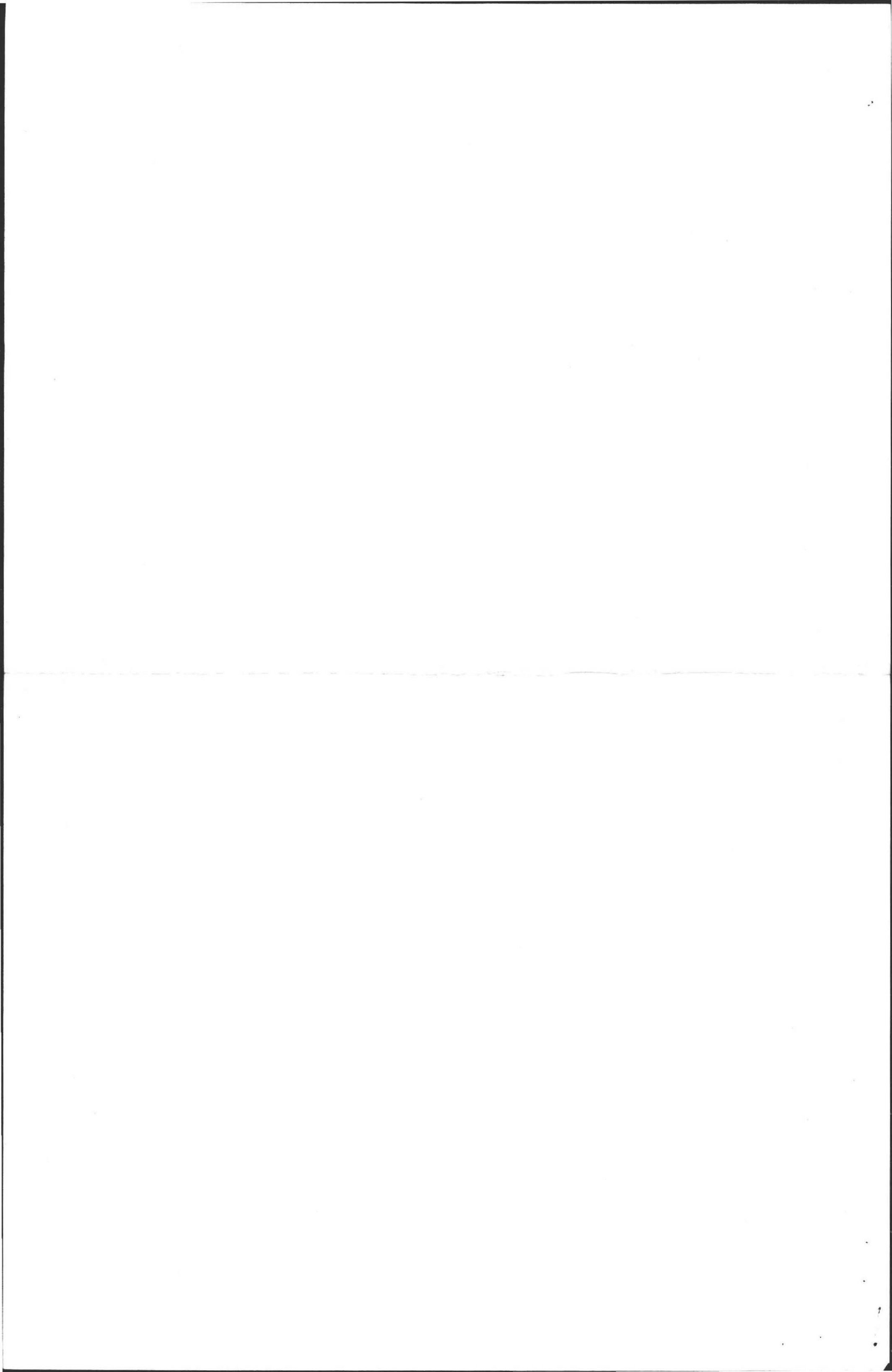

No. 87-27

THE COMMONWEALTH OF MASSACHUSETTS
BOARD OF HEALTH

Town OF Amherst

Application for Disposal Works Construction Permit



Application is hereby made for a Permit to Construct () or Repair (X) an Individual Sewage Disposal System at:

1680 Southeast St.
Charles Thompson
1680 South east St. Amherst, MA

Type of Building Dwelling — No. of Bedrooms 4 Expansion Attic () Garbage Grinder (X)
Other — Type of Building No. of persons Showers () — Cafeteria ()
Other fixtures

Design Flow 55 gallons per person per day. Total daily flow 440 gallons.
Septic Tank — Liquid capacity 1000 gallons Length 8.5' Width 5' Diameter Depth 5.33'
Disposal Trench — No. Width 18' Total Length 25' Total leaching area 4.50 sq. ft. Bottom
Seepage Pit No. Diameter Depth below inlet Total leaching area sq. ft.
Other Distribution box (X) Dosing tank ()
Percolation Test Results Performed by Filias Enterprises, Inc. Date Oct. 16, 1987
Test Pit No. 1 2 minutes per inch Depth of Test Pit 7' Depth to ground water 70"
Test Pit No. 2 minutes per inch Depth of Test Pit Depth to ground water

Description of Soil Soil log attached
Nature of Repairs or Alterations — Answer when applicable

Agreement:
The undersigned agrees to install the aforescribed Individual Sewage Disposal System in accordance with the provisions of TITLE 5 of the State Sanitary Code — The undersigned further agrees not to place the system in operation until a Certificate of Compliance has been issued by the board of health.

Signed _____ Date _____
Application Approved By _____ Date _____
Application Disapproved for the following reasons: _____ Date _____
Permit No. _____ Issued _____ Date _____

THE COMMONWEALTH OF MASSACHUSETTS
BOARD OF HEALTH

Town OF Amherst

Certificate of Compliance

THIS IS TO CERTIFY, That the Individual Sewage Disposal System constructed () or Repaired (X) by _____ Installer _____ at 1680 South east St. has been installed in accordance with the provisions of TITLE 5 of The State Sanitary Code as described in the application for Disposal Works Construction Permit No. _____ dated _____

THE ISSUANCE OF THIS CERTIFICATE SHALL NOT BE CONSTRUED AS A GUARANTEE THAT THE SYSTEM WILL FUNCTION SATISFACTORY.
DATE _____ Inspector _____

CHECK OR FILL IN WHERE APPLICABLE

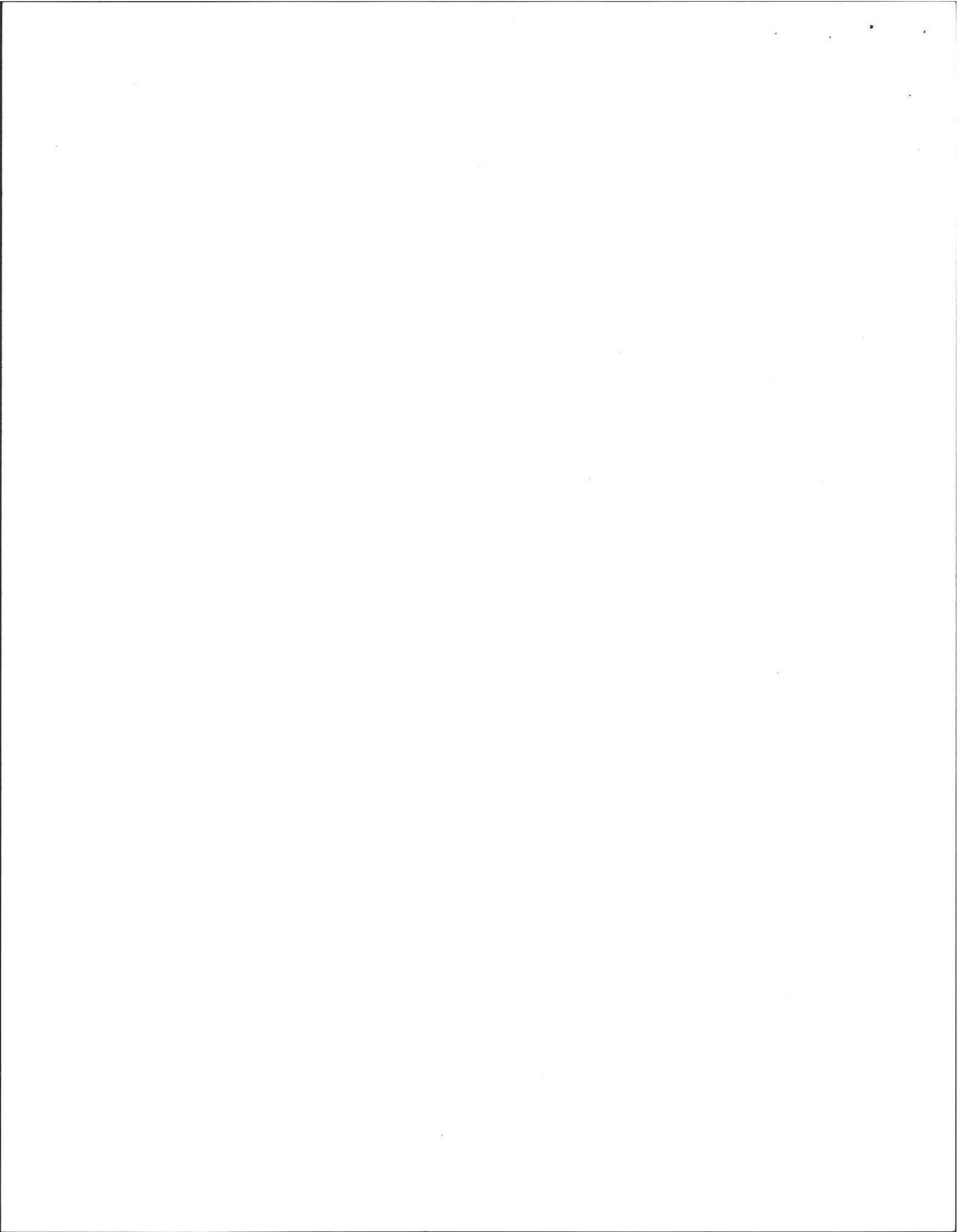

DEEP SOIL LOGS

OWNER CHARLES THOMPSON

DATE OCT. 16, 1987

LOCATION 1650 S. EAST ST.
AMHERST, MA

OBSERVER F. FILIOS

B of H Peter Kolotiez

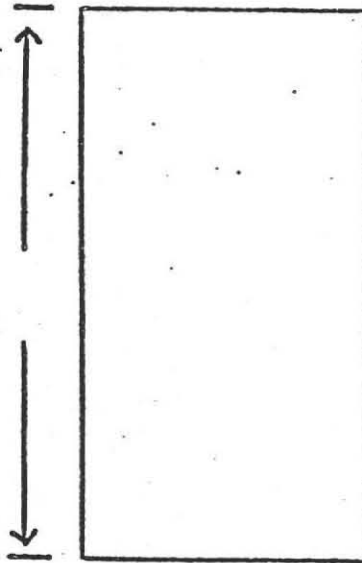
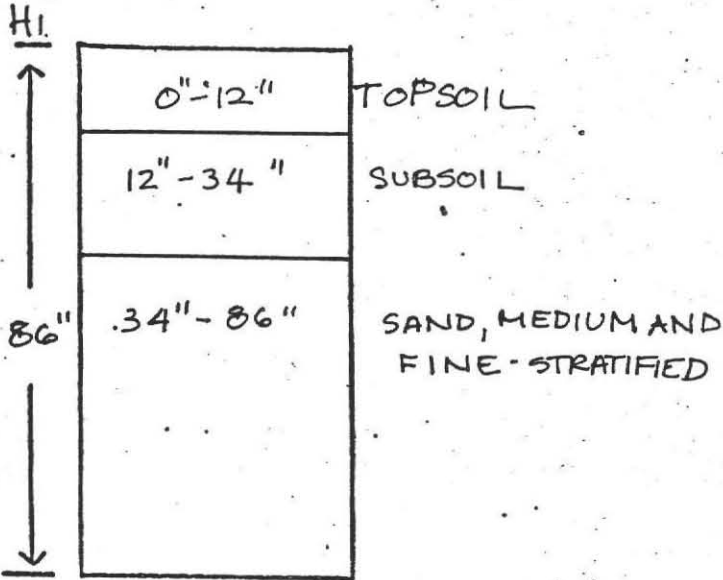

GROUND WATER 70"

GROUND WATER _____

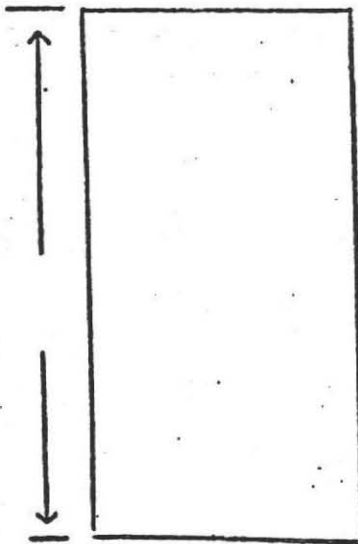

GROUND WATER _____

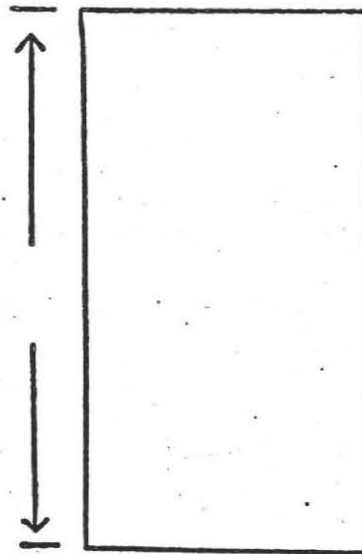

GROUND WATER _____

PERCOLATION RATE AT 55:

2 min./inch



Filios Enterprises Inc.

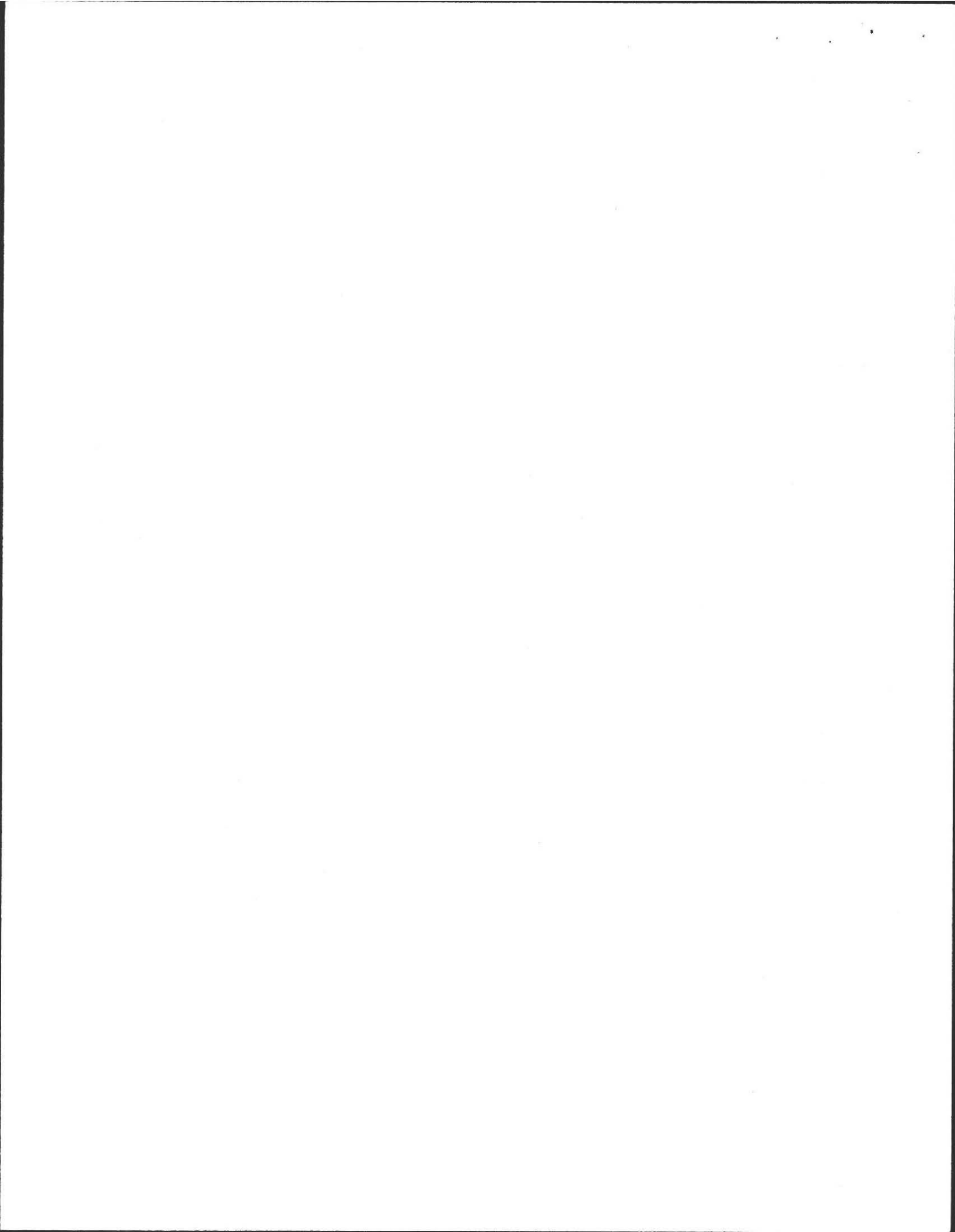

PLAN SHOWING SEWAGE DISPOSAL

For: Charles Thompson
 1680 South East St.
 Amherst, MA 01002

FILIOS ENTERPRISES INC.
 69 PELHAM RD.
 AMHERST, MA 01002 L.Z.

Date: 10.28.87
 Scale: 1" = 30'

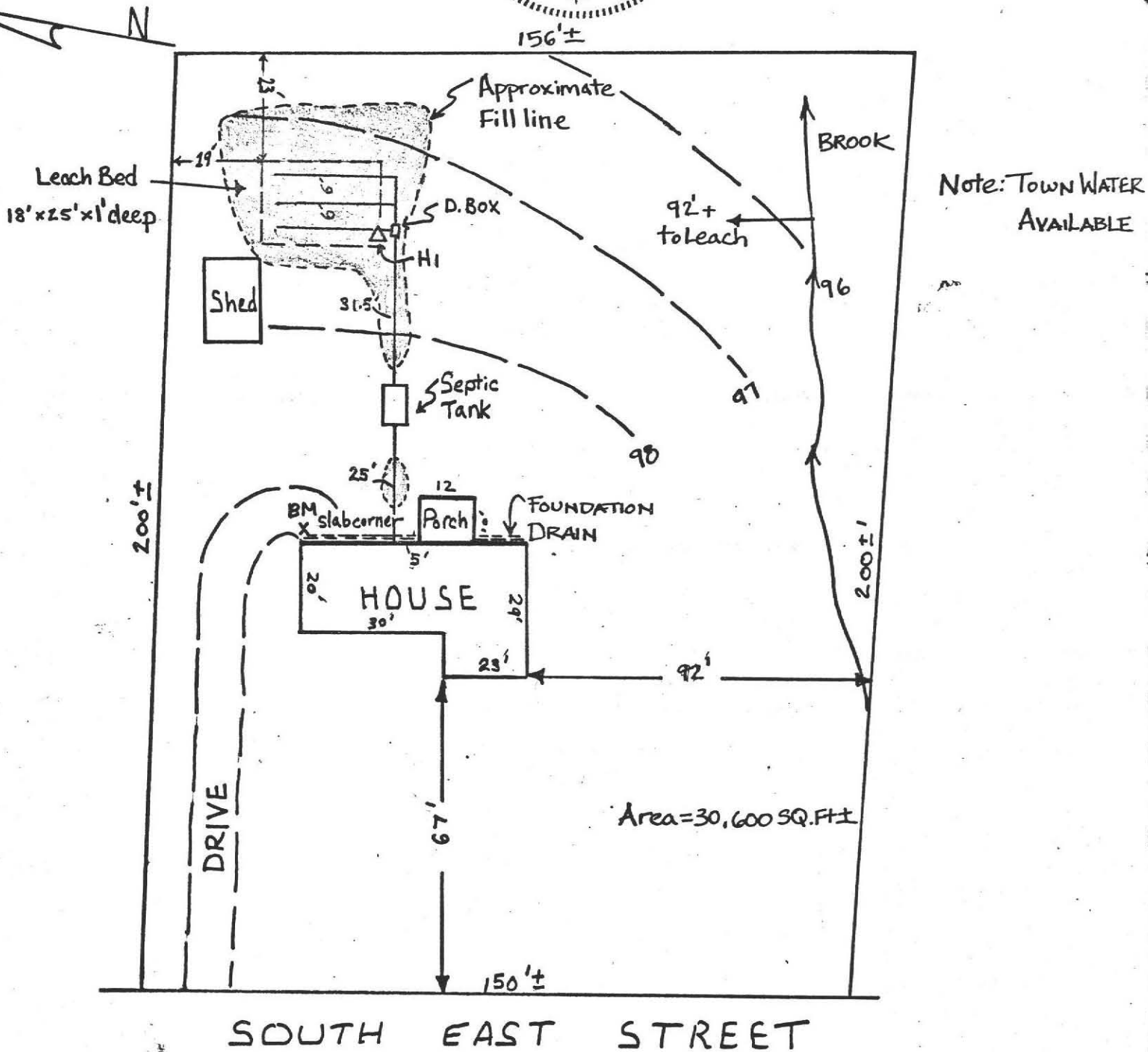

Note: TOWN WATER AVAILABLE

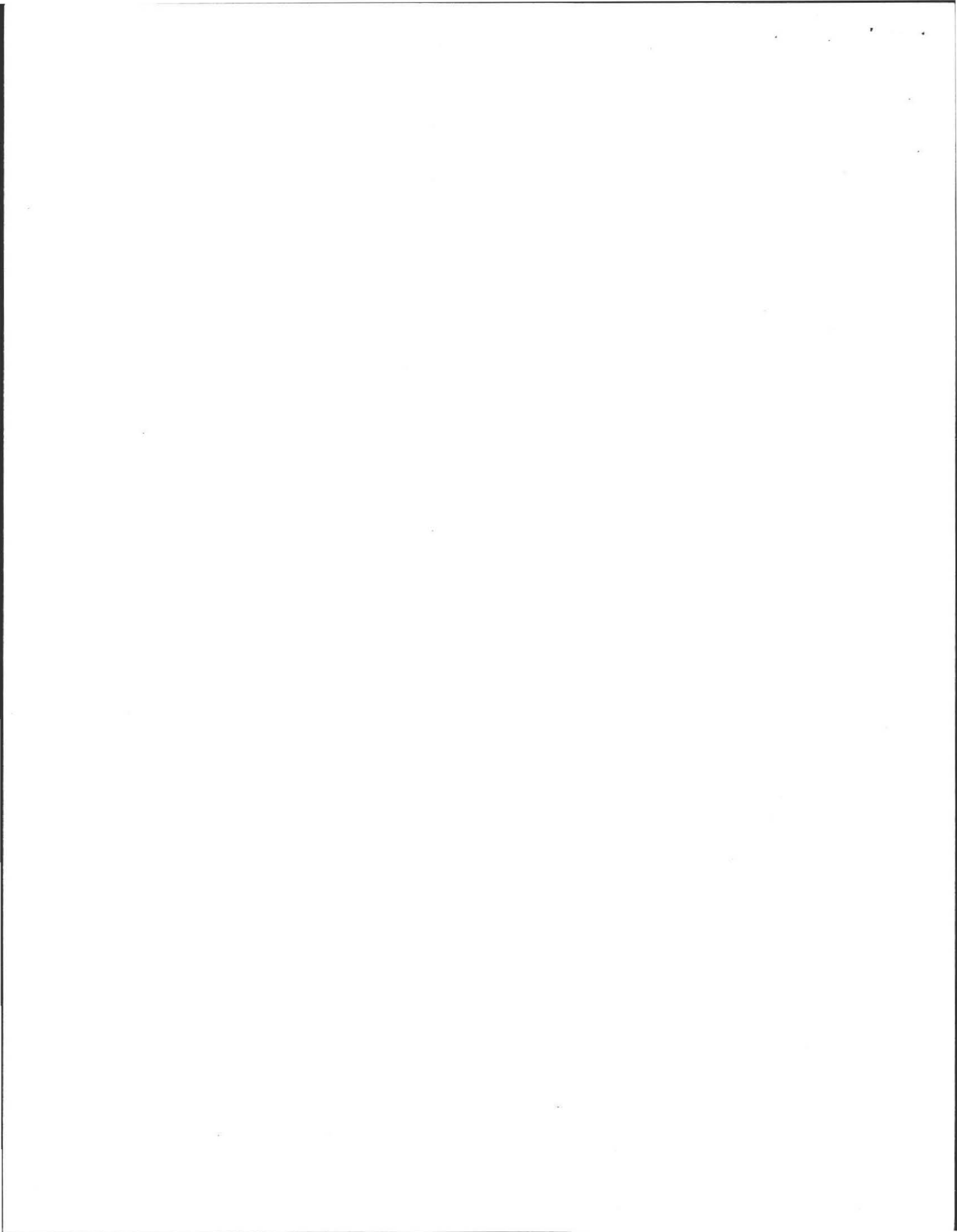

PROFILE OF SEPTIC SYSTEM

BY: FILIOS ENTERPRISES INC.
 69 PELHAM RD.
 AMHERST MA 01002
 I.Z.

DATE: 10.28.87
 SCALE: Horizontal 1" = 10'
 Vertical 1" = 3'

FOR: CHARLES THOMPSON
 SITE: 1680 SOUTHEAST ST.
 AMHERST, MA 01002

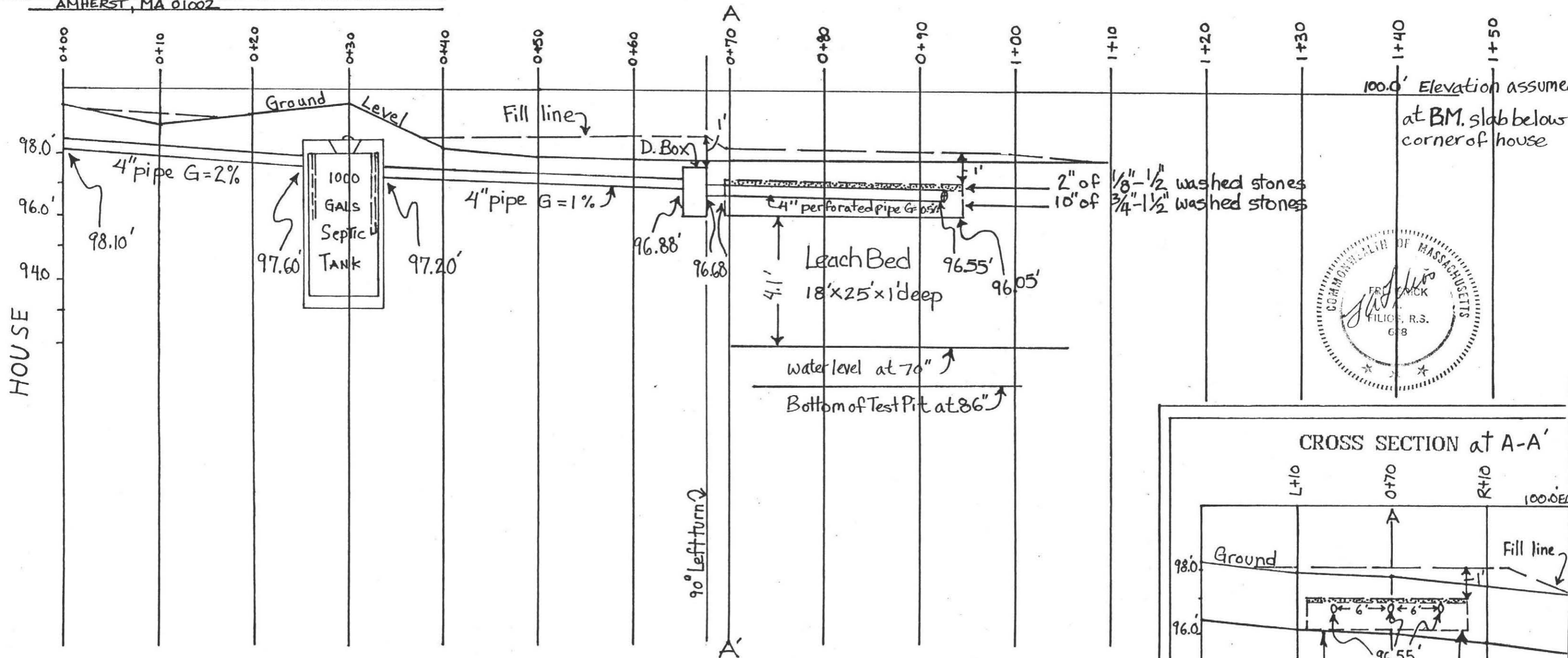

SPECIFICATIONS

All materials and construction will be in accordance with Commonwealth of MA D. E. Q. E. State Environmental Code Title 5.

CALCULATIONS

4 Bedroom @ 110 = 440 Gals/day Required
 Perc. Rate = 2 min./inch
 Leach Bed 18'x25'x1'deep
 Bottom area 18x25 = 450 SQ. FT.
 450 x 1.0 = 450 Gals/day Available

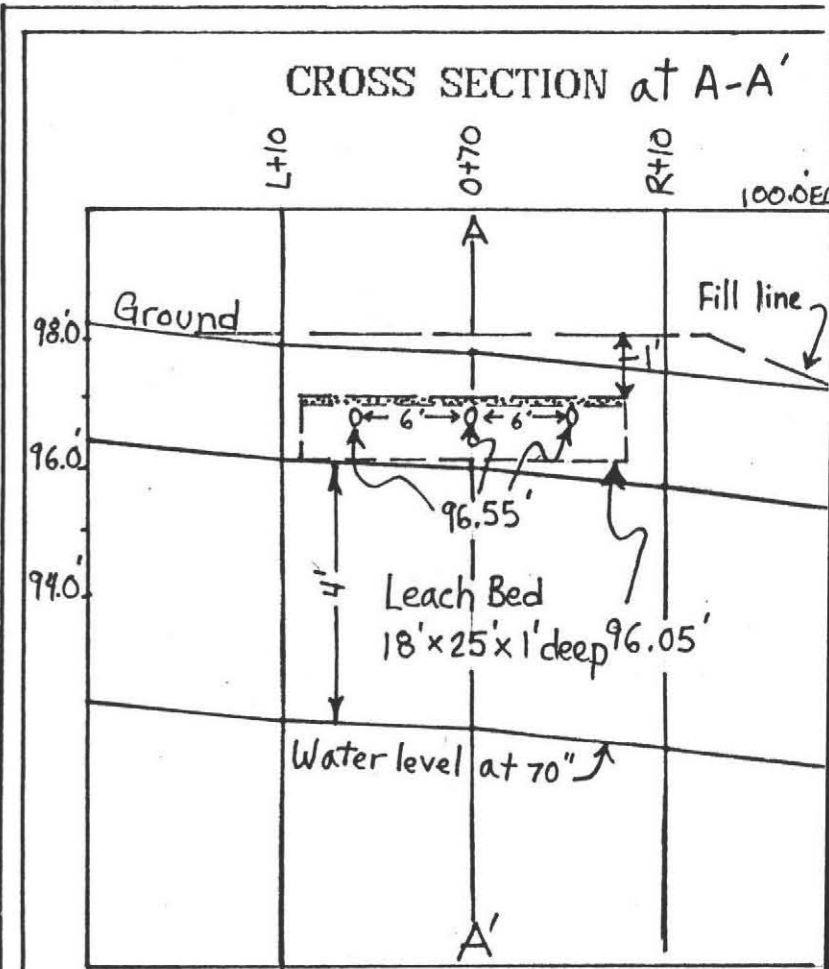

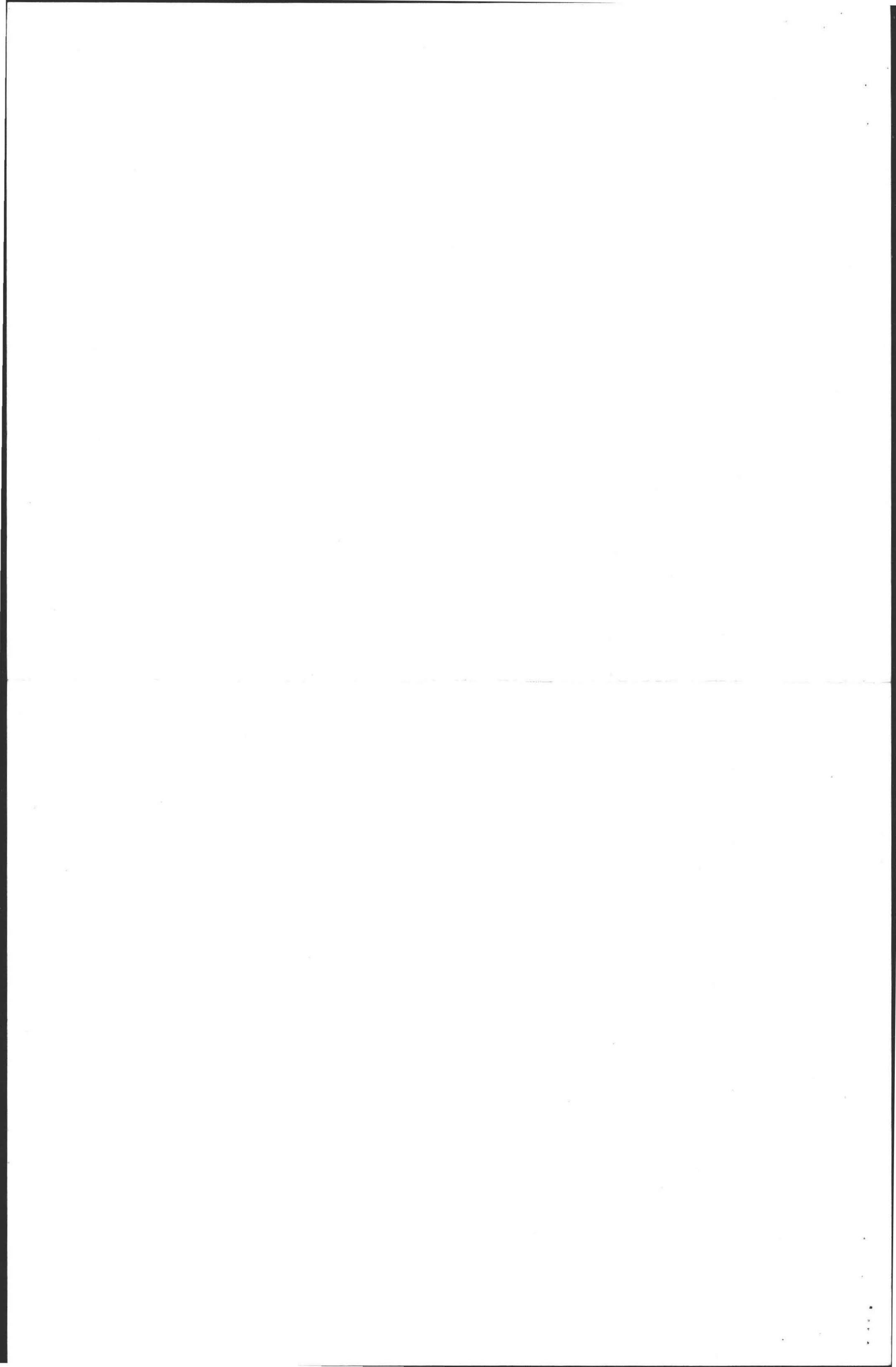

File

NOV 12 1987

Nov. 12, 1987

Board of Health
Town of Amherst
Amherst, Ma.

To the Board of Health:

I am requesting a variance from the 6 foot groundwater separation regulation that applies to septic system installation. My leach field has failed. Filios Enterprises has redesigned the system. Their plans are in your possession. Thank you for your prompt attention to this. I have notified abutters of my request. I have also spoken with Pete Westover who has indicated that the system appears to be exempt from Conservation Commission regulations under Ch. 131. I will provide the Conservation Commission with a copy of the septic system plans.

Sincerely,

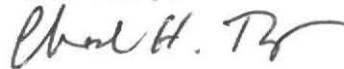

Charles H. Thompson
1680 Southeast St.
Amherst

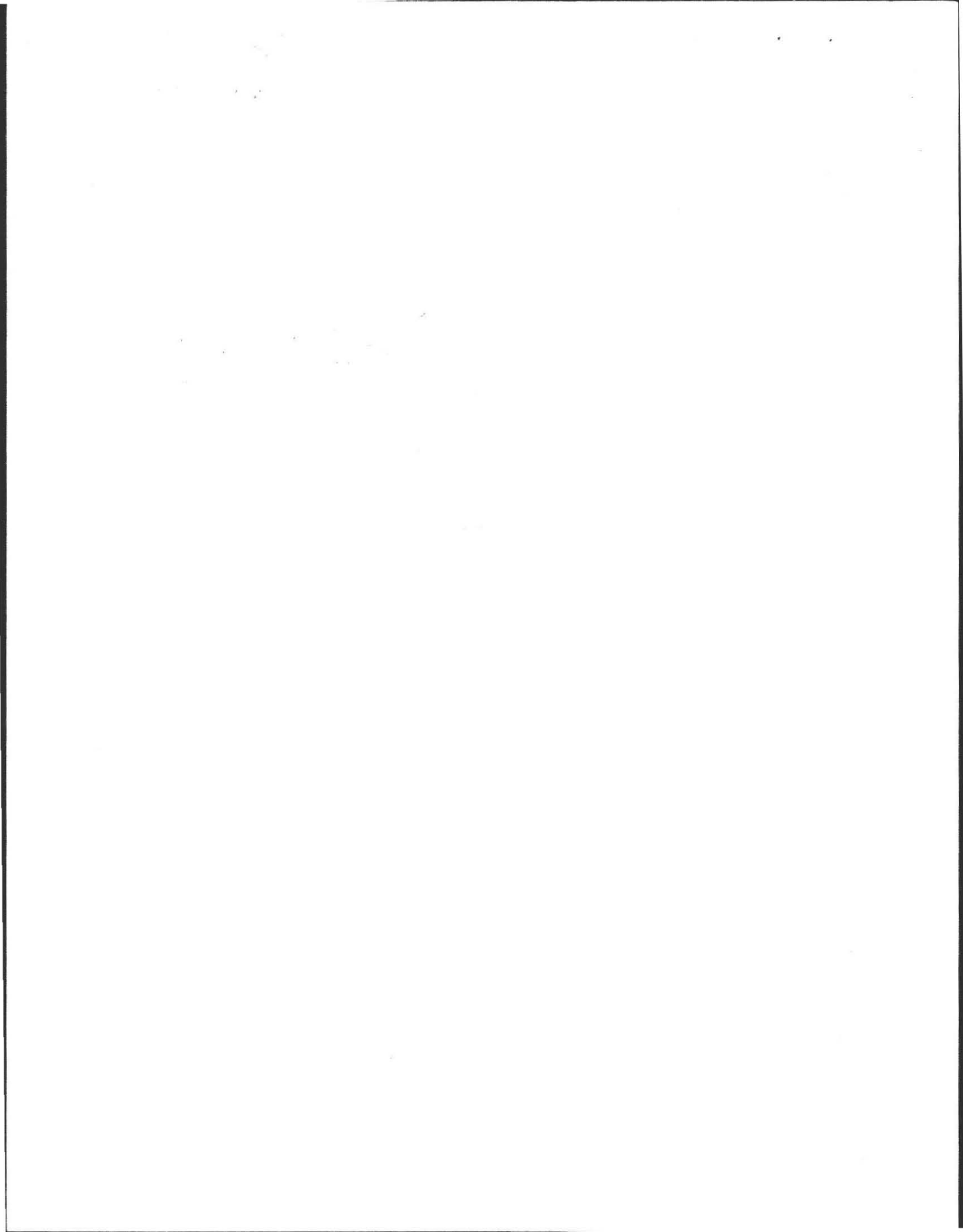

Town of



AMHERST

Massachusetts

Bettye Anderson Frederic, Director

AMHERST HEALTH DEPARTMENT
70 BOLTWOOD WALK
AMHERST, MA 01002-2128
(413) 253-7077

November 20, 1987

COPY

Charles Thompson
1680 South East Street
Amherst, MA 01002

Dear Mr. Thompson:

I have again discussed your septic variance with our Interim Sanitarian. Together we have concluded that a variance is NOT needed due to the fact that your situation involves an existing system in need of repair or replacement. Kindly call when you are ready for your final system inspection.

Thank you for your assistance in this matter.

Sincerely,

Bettye Anderson Frederic

Bettye Anderson Frederic
Health Director

Charles Thompson 1680 Southeast St

This is a repair existing system failing;
need variance to ground water separation Amherst
Board of Health and review also necessary by
Conservation Commission.

Variance necessary to eliminate existing potential
health hazard.

Noted
Need variance Request Conservation Review

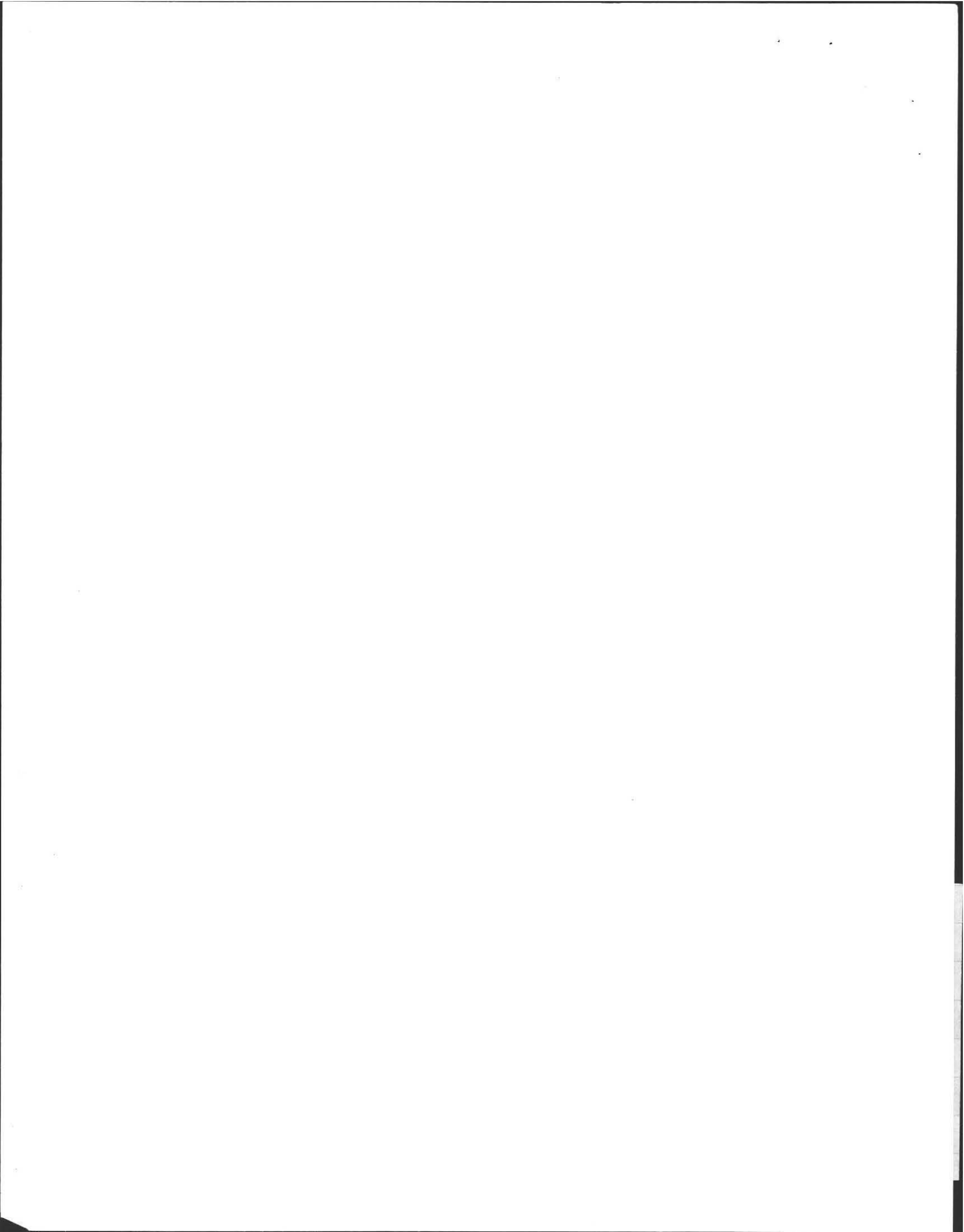

NOV 20 1987

Town of



AMHERST *Massachusetts*

TOWN HALL
4 BOLTWOOD AVENUE
AMHERST, MA. 01002-2351

CONSERVATION COMMISSION
AND
CONSERVATION DIRECTOR
(413) 256-0413

MEMORANDUM TO: Bettye Anderson Frederic

FROM: Ineke Dickman, for Pete Westover, *I.D.*
Conservation Director

SUBJ: Request for a Title V Permit

DATE: November 19, 1987

I checked out 1680 South East Street and roughly measured distances from wetland & brook.

The distance from leach field to brook seems less than 92 feet, but is definitely more than the required 50 feet. So it looks OK.

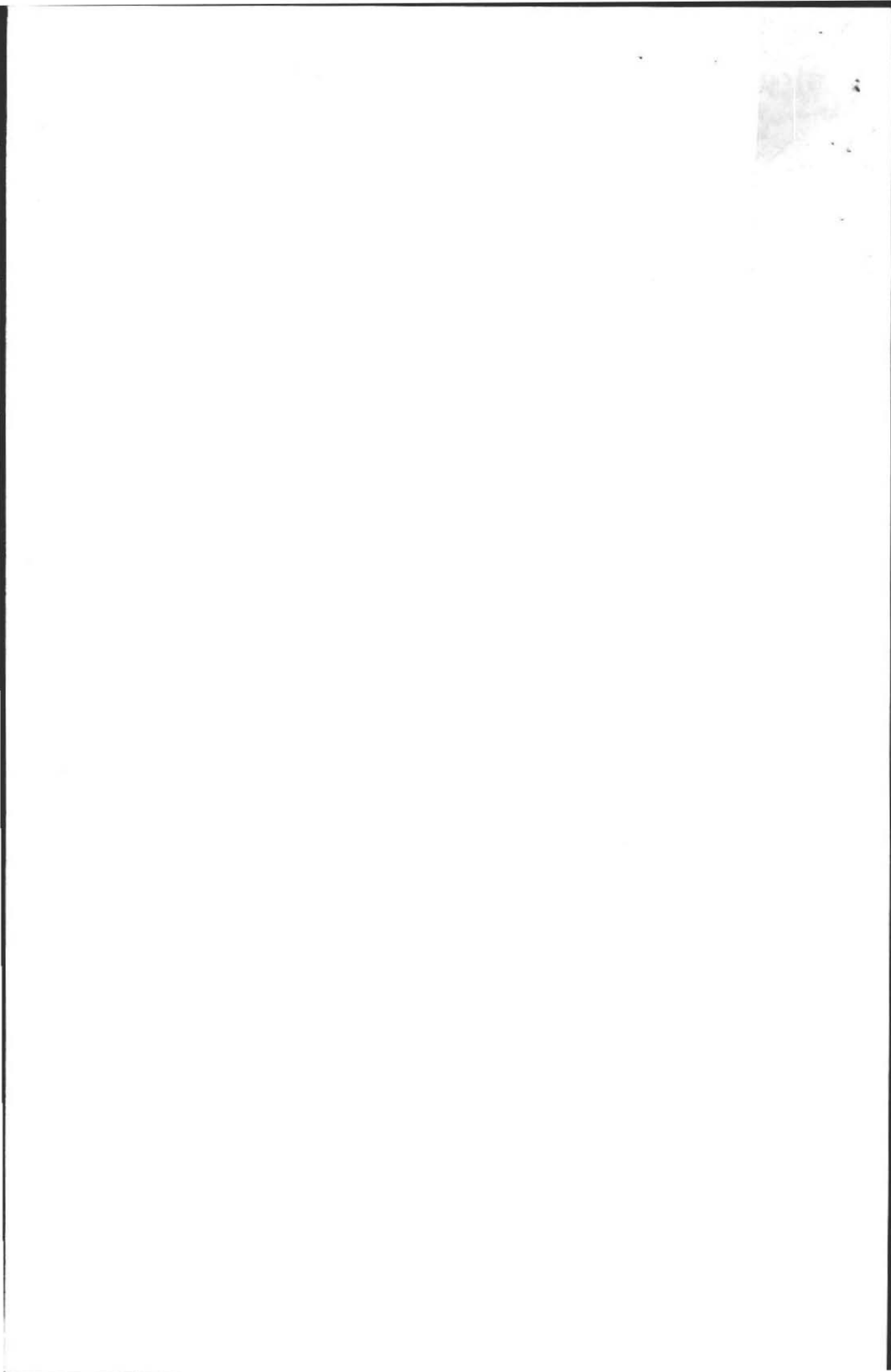

Town of



AMHERST

NOV 20 1987

Massachusetts

AMHERST HEALTH DEPARTMENT
(413) 253-7077

November 12, 1987

To: Peter Westover

From: Bettye Anderson Frederic *BAF*

Re: Request for a Title V Permit

The Health Department has been requested to grant a Title V Permit to Mr. Charles Thompson at 1680 South East Street due to a failing septic system. Our inspector had some concerns regarding the closeness of this project to the Wetland Buffer. Could you check this out and let us know.

Thank you.

Copy of plan attached.

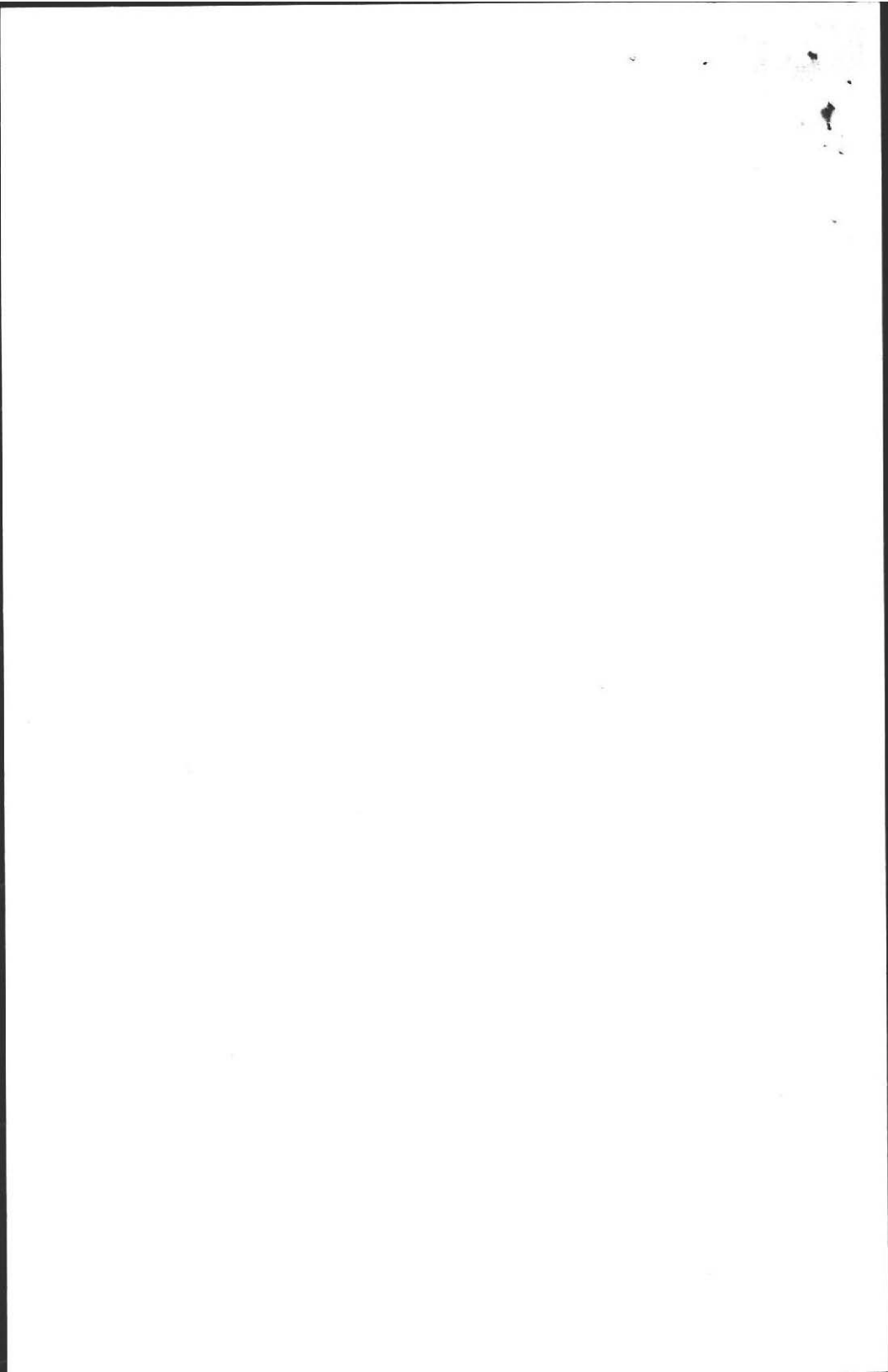

Charles Thompson
1680 South East St.
Amherst, MA 01002

FILIOS ENTERPRISES INC.
69 PELHAM RD.
AMHERST, MA 01002

NOV 20 1987

Date: 10.28.87
Scale: 1" = 30'

