

No. 86-2

#337

FEE

\$90

pd

ck

#746

THE COMMONWEALTH OF MASSACHUSETTS

BOARD OF HEALTH

Town OF Amherst, MA. 01002

Application for Disposal Works Construction Permit

Application is hereby made for a Permit to Construct (✓) or Repair () an Individual Sewage Disposal System at:

Shutesbury Road

Edward M. IENTKA

Location - Address

161 Chestnut St Amherst, MA 01002

or Lot No.

Richard M. Ientka

Owner

Belcourt Rd Amherst

Address

D.M.O. Const

Installer

Address

Type of Building

Size Lot 1.2 Acres Sq. feet

Dwelling - No. of Bedrooms 3 Expansion Attic ()

Garbage Grinder (✓)

Other - Type of Building FRAME No. of persons MAX. 6

Showers () - Cafeteria ()

Other fixtures

Design Flow 55 gallons per person per day. Total daily flow 330 gallons.

Septic Tank - Liquid capacity 1000 gallons Length 10' Width 5' Diameter - Depth 5' 300 sq. ft.

Disposal Trench - No. Field Width 3' Total Length 150' Total leaching area 450 sq. ft.

Seepage Pit No. Diameter 3' Depth below inlet - Total leaching area 450 sq. ft.

Other Distribution box (x) Dosing tank ()

Percolation Test Results Performed by Frederick A. Filios, R.S. Date 1/26/83

Test Pit No. 1 5.66 minutes per inch Depth of Test Pit 40" Depth to ground water 6.5'

Test Pit No. 2 - minutes per inch Depth of Test Pit 7.0' Depth to ground water 6.5'

C. Drake Observer for the Town.

Description of Soil See Soil logs attached

Nature of Repairs or Alterations - Answer when applicable

Agreement:

The undersigned agrees to install the aforescribed Individual Sewage Disposal System in accordance with the provisions of TITLE 5 of the State Sanitary Code - The undersigned further agrees not to place the system in operation until a Certificate of Compliance has been issued by the board of health.

Signed Edward M. Ientka 2/14/86

Application Approved By C. Drake Jr. 2-14-86

Application Disapproved for the following reasons:

Permit No. 86-2

Issued 2-14-86 Date

THE COMMONWEALTH OF MASSACHUSETTS

BOARD OF HEALTH

OF

Certificate of Compliance

THIS IS TO CERTIFY, That the Individual Sewage Disposal System constructed () or Repaired () by

Installer

at

has been installed in accordance with the provisions of TITLE 5 of The State Sanitary Code as described in the application for Disposal Works Construction Permit No. dated

THE ISSUANCE OF THIS CERTIFICATE SHALL NOT BE CONSTRUED AS A GUARANTEE THAT THE SYSTEM WILL FUNCTION SATISFACTORY.

DATE Inspector

THE COMMONWEALTH OF MASSACHUSETTS

BOARD OF HEALTH

No. 86-2

Town OF Amherst

FEE

\$90

Disposal Works Construction Permit

Permission is hereby granted Ed M. Ientka by DMO Const to Construct (x) or Repair () an Individual Sewage Disposal System

at No. Lot 100 Shutesbury Street

as shown on the application for Disposal Works Construction Permit No. 86-2 Dated 2-14-86

DATE 2-14-86 Board of Health

CHECK OR FILL IN WHERE APPLICABLE

Amberley, 1914

1914

Amberley, 1914

Amberley, 1914

1914

1914

1914

1914

1914

1914

1914

1914

1914

1914

X

1914

1914

1914

1914

1914

SHUTESBURY ROAD

150.00

IRON BAR FOUND
10.24'

HENRY B. &
KATHARINE H. SCHOE

1.202 Ac.

other Land
of W.D. Cowls, Inc.

441.03'

283.56'

Mag N

Pit + Perc

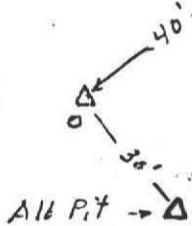

All Pit ->

167.46'

IP in stones

PLATION TEST
TION

Cowls Inc.
eque Rd
erst Mass
0'
erick Filios

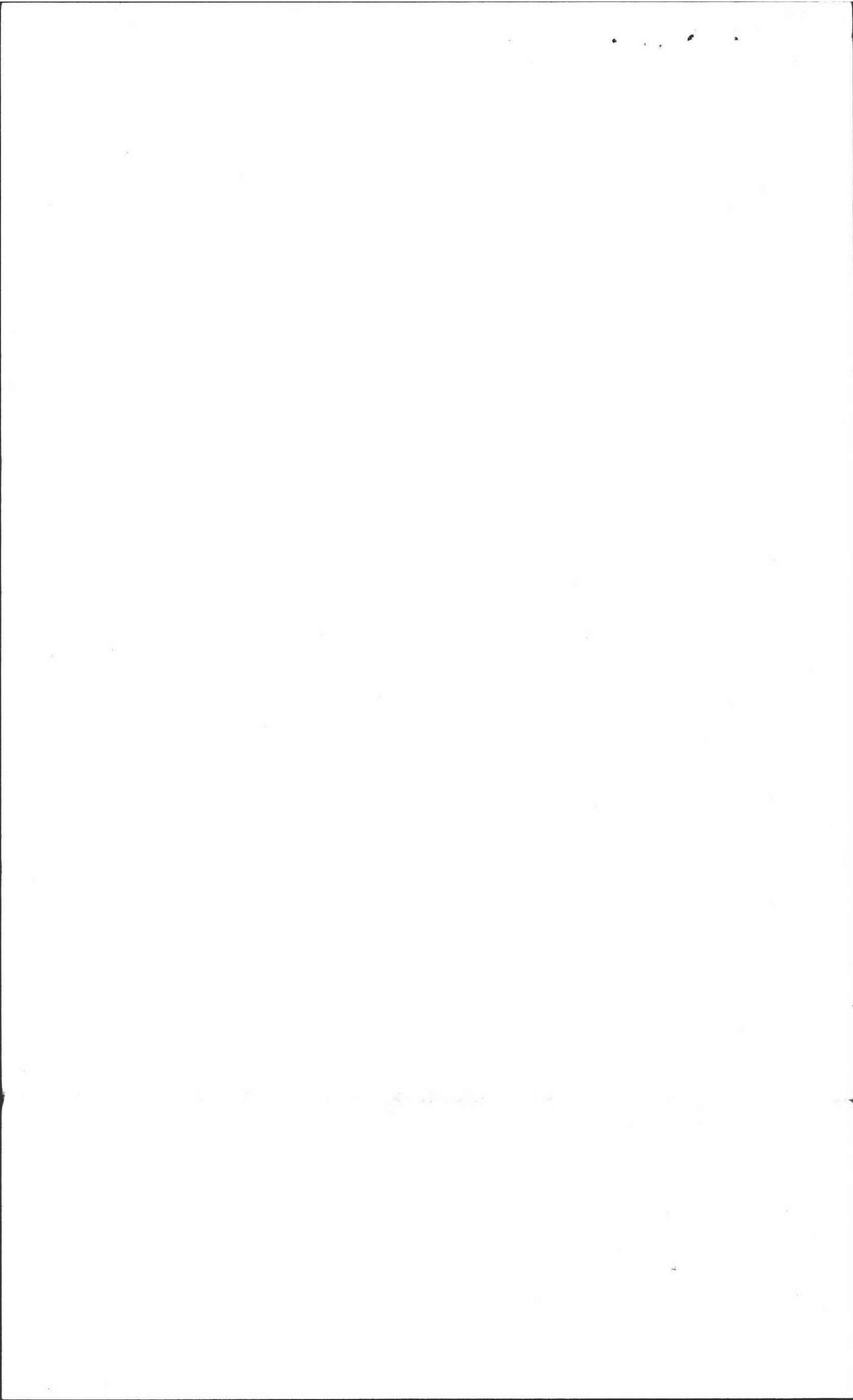

ESBURY ROAD
 HIGHWAY LAYOUT ~ 2 RODS WIDE

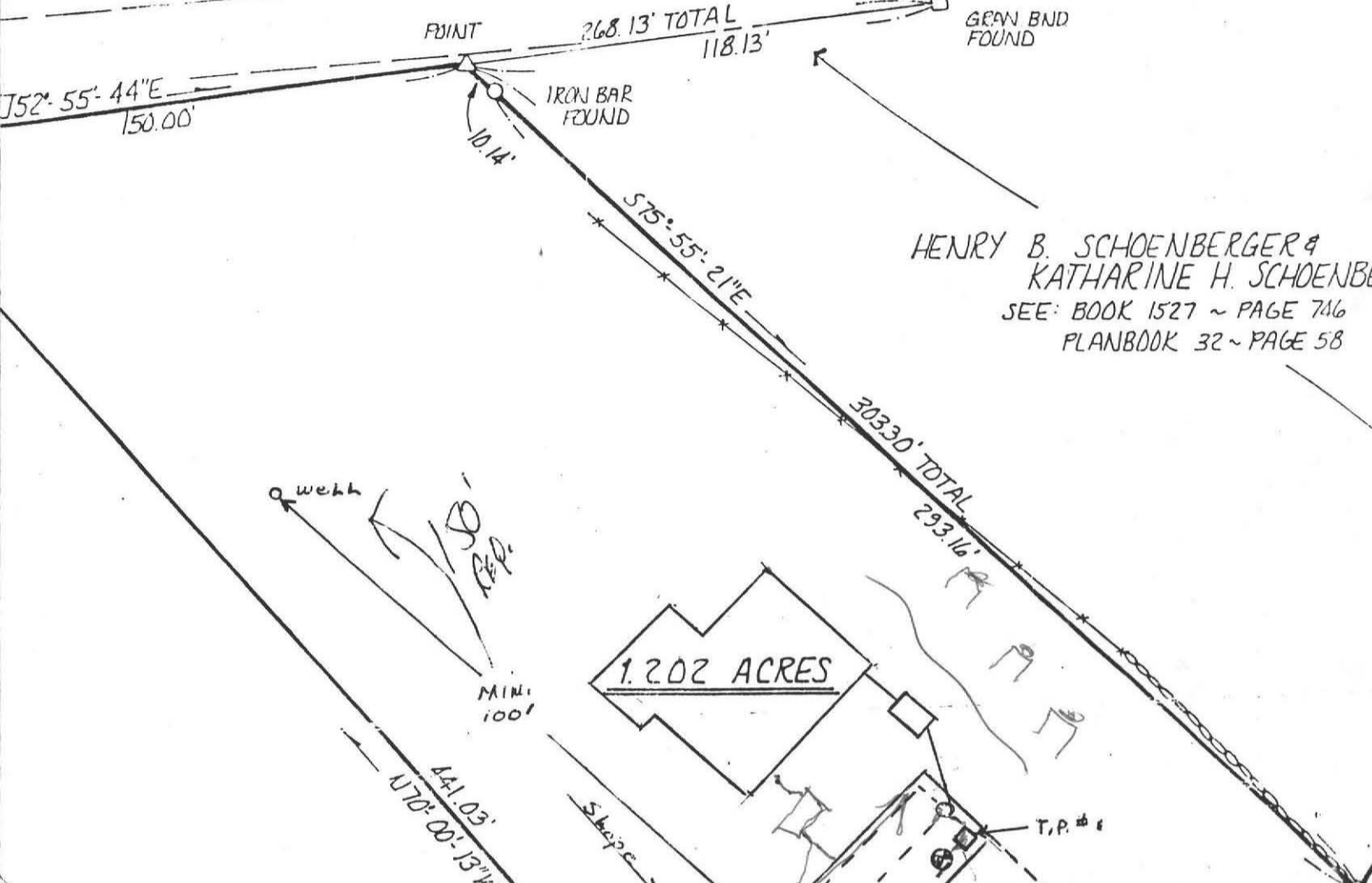

HENRY B. SCHOENBERGER &
 KATHARINE H. SCHOENBERGER
 SEE: BOOK 1527 ~ PAGE 716
 PLANBOOK 32 ~ PAGE 58

OTHER LAND OF
 D. COWLES, INC.
 BOOK 1213 ~ PAGE 346
 WESTERST CADASTRE
 SHEET 9-B ~ PARCEL 11

1.202 ACRES

Change to
 3 TRENCHES x 50'
 FOLLOWING CONTOUR

Needs:

- 1 - 1000 GAL. SEPTIC TANK.
- 1 - DIST. BOX
- 3 - Leach TRENCHES x 50'

DATA:

- ☐ = Test Pit - See notes
- ⊕ = PERK TEST @ 40" 1" / 5.66 MINS.

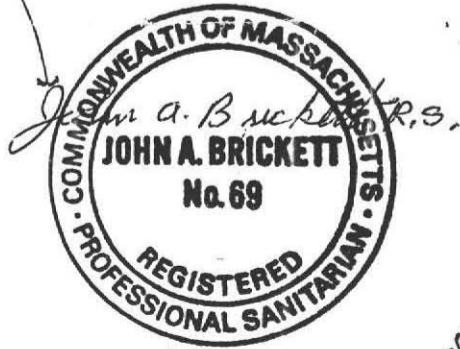

2/7/86
 1" = 40'

APPROXIMATE
 TOWN LINE

WALTER M. BANFIELD &
 HERTHA M. BANFIELD
 SEE: BOOK 1110 ~ PAGE 461
 TRACT 1

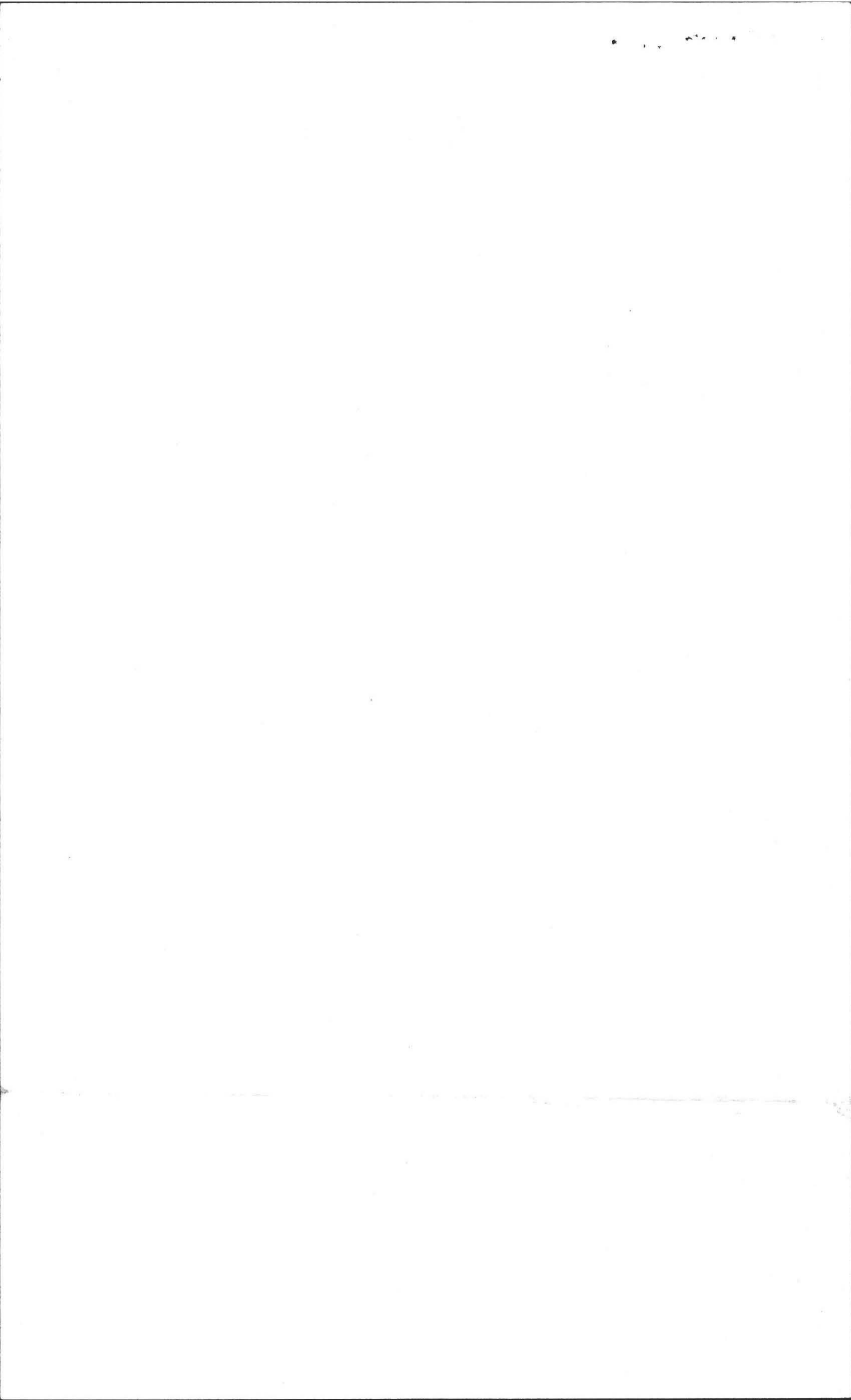

BOARD OF HEALTH

TOWN OF AMHERST, MASSACHUSETTS

33.7 SAUTESBURY RD

Important Information Regarding Your Private Sewage Disposal System

DISPLAY THIS DOCUMENT IN A PROMINENT PLACE

Owner E.J. MIENYKA Address 161 Chestnut St Amherst

Installer DMD Const. Address BELLEVILLE RD Amherst

Date Installation Inspected and Approved 8/21/86

Description of System: Tank Capacity: 1000

Leach Field () Bed () Seepage Pits (2) Square Feet: 300 Bottom 200 Sides

Garbage Grinder Yes () - No (X) No. Bedrooms: 3 No. People 6

AS - BUILT PLAN:

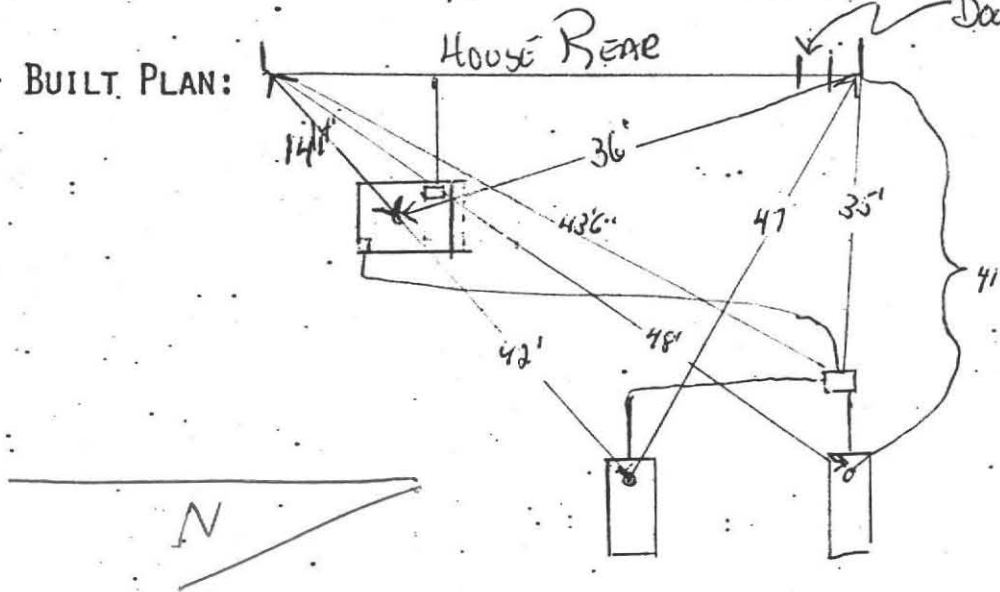

PROPER MAINTENANCE OF YOUR PRIVATE SEWAGE DISPOSAL SYSTEM

1. This system must be inspected periodically and the tank pumped out at an interval not to exceed 3 years.
2. For your protection sanitary pumpers are licensed by the Amherst Board of Health.
3. Regular pumping is crucial to avoid early failure and costly repairs of the system.
4. DO NOT dispose into the system such items as rags, string, sanitary napkins, coffee grounds as they can cause it to clog and fail.
5. Further information can be obtained by contacting your Health Department at 253-7077.

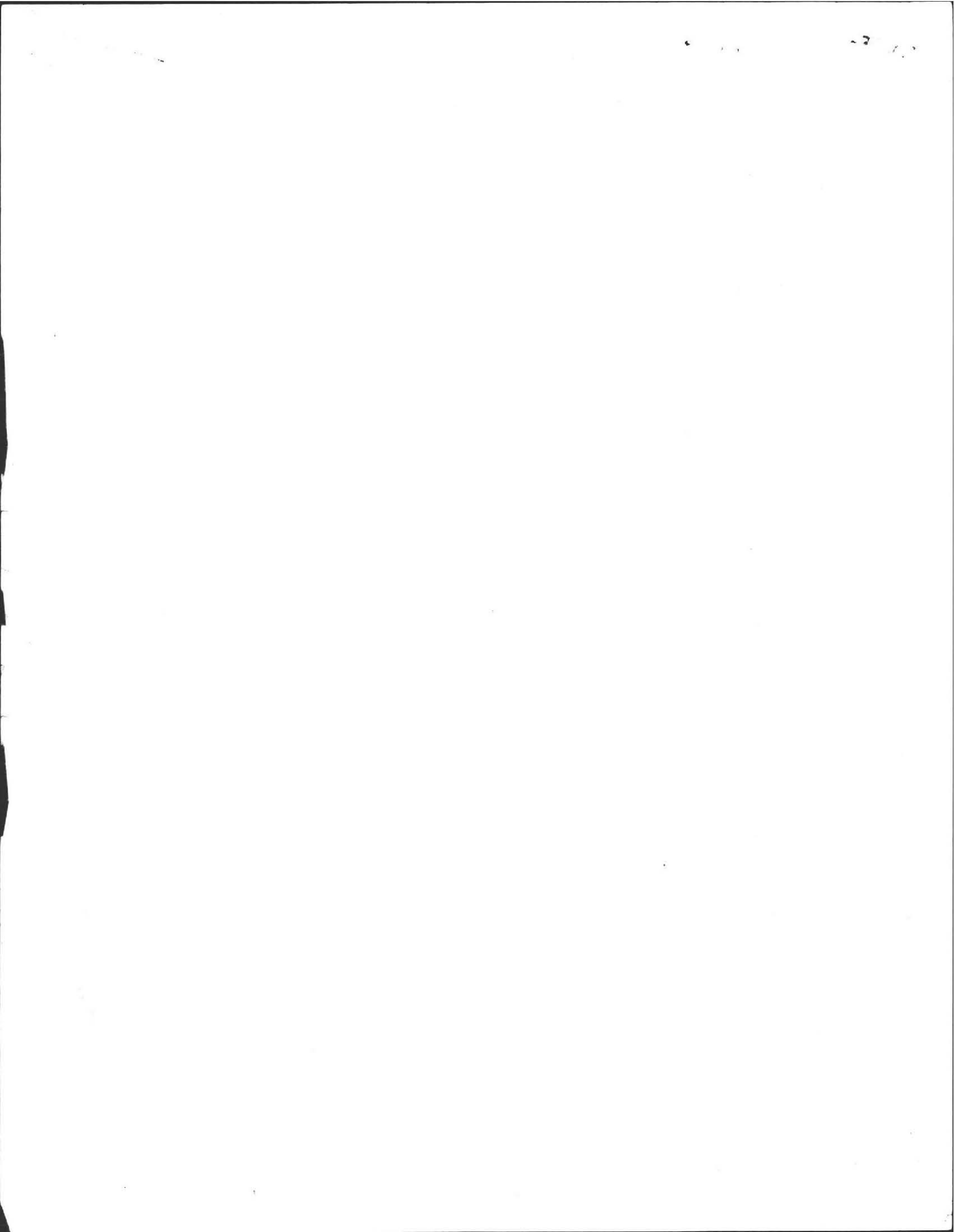

BOARD OF HEALTH

TOWN OF AMHERST, MASSACHUSETTS

337 SAUTESBURY RD.

Important Information Regarding Your Private Sewage Disposal System

DISPLAY THIS DOCUMENT IN A PROMINENT PLACE

Owner E.J. MIENKA Address 161 CHESTNUT ST AMHERST

Installer DMD CONST. Address BELMONT RD AMHERST

Date Installation Inspected and Approved 8/21/86

Description of System: Tank Capacity: 1000

Leach Field () Bed () Seepage Pits (2) Square Feet: 300 Bottom 200 Sides

Garbage Grinder Yes () - No (X) No. Bedrooms: 3 No. People 6

AS - BUILT PLAN:

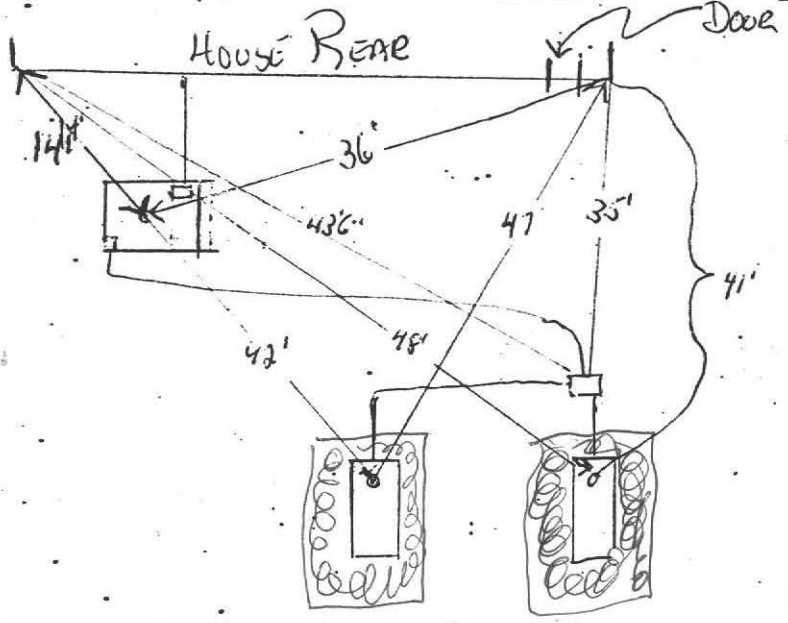

PROPER MAINTENANCE OF YOUR PRIVATE SEWAGE DISPOSAL SYSTEM

1. This system must be inspected periodically and the tank pumped out at an interval not to exceed 3 years.
2. For your protection sanitary pumpers are licensed by the Amherst Board of Health.
3. Regular pumping is crucial to avoid early failure and costly repairs of the system.
4. DO NOT dispose into the system such items as rags, string, sanitary napkins, coffee grounds as they can cause it to clog and fail.
5. Further information can be obtained by contacting your Health Department at 253-7077.

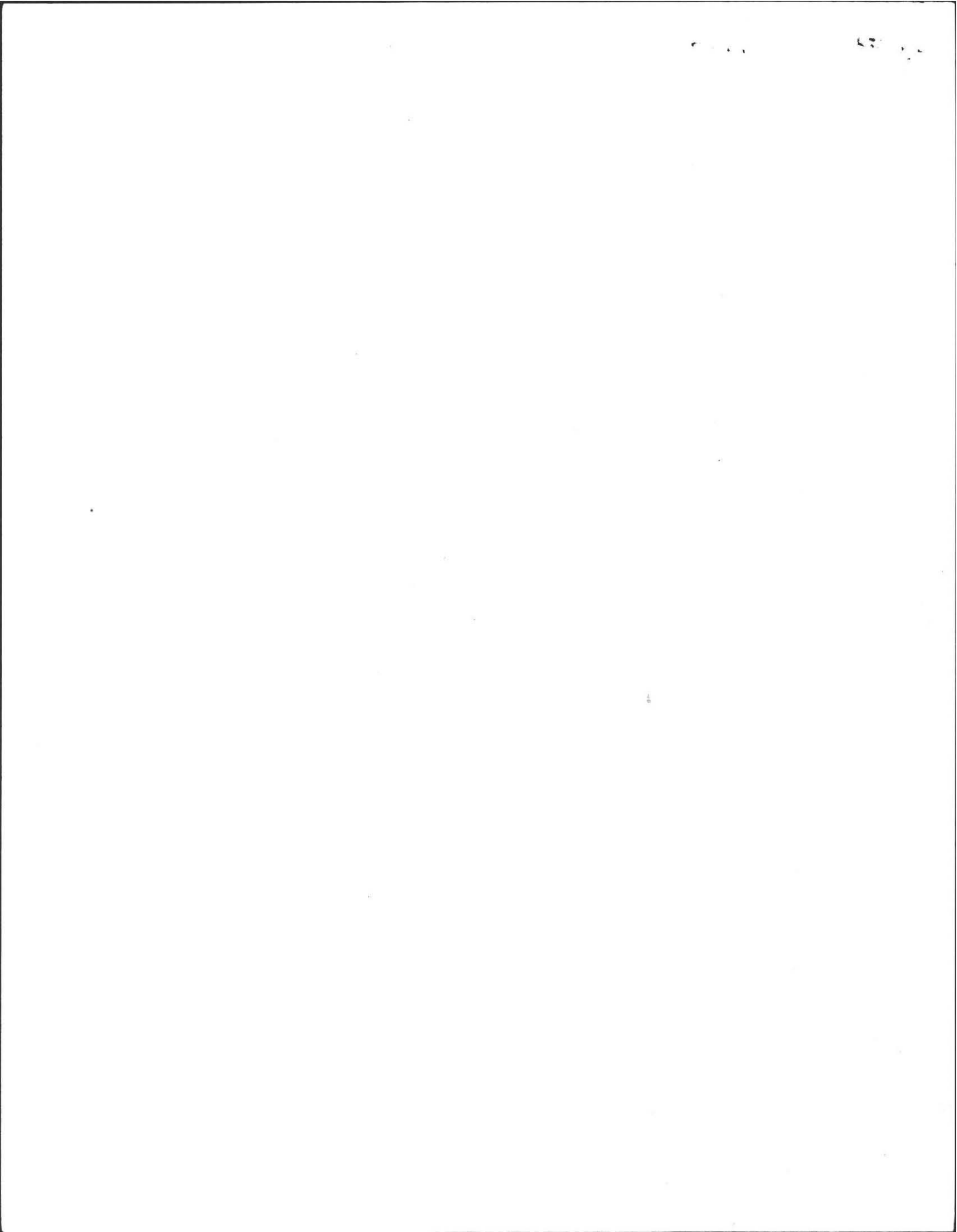

BOARD OF HEALTH

TOWN OF AMHERST, MASSACHUSETTS

SKUTESBORO ROAD

Important Information Regarding Your Private Sewage Disposal System

DISPLAY THIS DOCUMENT IN A PROMINENT PLACE

Owner L. J. MIENYKA Address CHESTNUT ST AMHERST

Installer DMO CONSTRUCTION Address BELMONT RD AMHERST

Date Installation Inspected and Approved 8/21/86

Description of System: Tank Capacity: 1000 300 SIDES

Leach Field () Bed () 2 Seepage Pits (X). Square Feet: 300 BOTTOM

Garbage Grinder Yes () No (X) No. Bedrooms: 3 No. People 6

AS - BUILT PLAN:

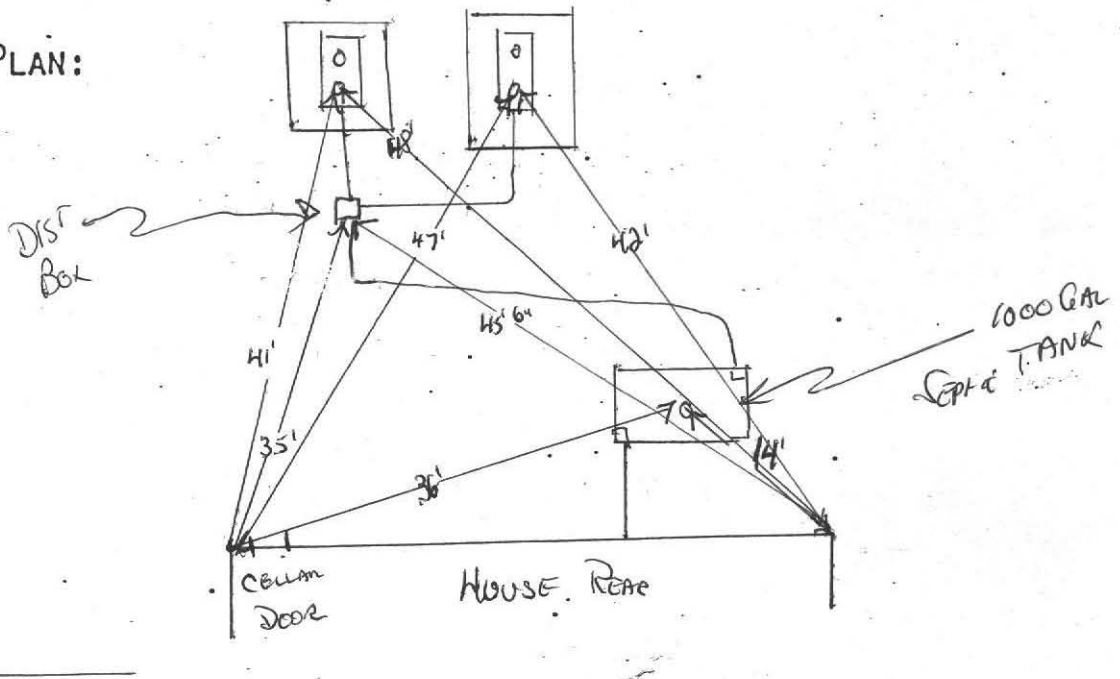

PROPER MAINTENANCE OF YOUR PRIVATE SEWAGE DISPOSAL SYSTEM

1. This system must be inspected periodically and the tank pumped out at an interval not to exceed 3 years.
2. For your protection sanitary pumpers are licensed by the Amherst Board of Health.
3. Regular pumping is crucial to avoid early failure and costly repairs of the system.
4. DO NOT dispose into the system such items as rags, string, sanitary napkins, coffee grounds as they can cause it to clog and fail.
5. Further information can be obtained by contacting your Health Department at 253-7077.

