

BOARD OF HEALTH, AMHERST, MASSACHUSETTS

#333

APPLICATION FOR DISPOSAL WORKS CONSTRUCTION PERMIT

No. 72-38 Date 11/10/72 Fee \$3.00 Date Rec'd. 11/10/72 By DGF

Application is hereby made for a permit to Construct (✓) or Repair () an Individual Sewage Disposal System at:

Location—Address SHAY ST. or Lot No. PAR #1

Owner GERALD D. McLELLAN Address 40 LEXINGTON ST.

Contractor Address

Type of Building Dimensions Size Lot 83,149 SF

Dwelling—No. of Bedrooms 5 Expansion Attic () Garbage Grinder (✓)

Other No. of persons Showers ()

Other fixtures

Town Water? YES Type of Well

Design Flow 50 gallons per person per day. Total daily flow 500 gallons

Septic Tank—Liquid capacity 1500 gallons Dimensions: L 10'-6" W 5'-8" D 5'-4"

Disposal Trench—No. 4 Width 3'-0" Total Length 333' Total leaching area 1000 sq. ft.

Disposal Bed—No. Diameter Depth below inlet Total leaching area sq. ft.

Dry Well—No. Diameter Depth below inlet Dimensions: x x

Other: Distribution box () No. Dosing tank ()

(Depth of Soil Line Below finished grade at foundation)

Percolation Test Results Performed by J. HART - HUNTLEY ENGR. Date 11/7/72

Test Pit No. 1 2 minutes per inch Depth of Test Pit 5'-6"

Test Pit No. 2 15 minutes per inch Depth of Test Pit 6'-6"

Description of Soil GRAVEL & GLACIAL TILL Depth to Ground Water NONE

Will disposal area be filled? Cut down?

(On reverse side or separate sheet, show plot plan with building. Include dimensions, distances from all boundaries. Show location of wells, streams, ledge, large trees, etc.)

AGREEMENT: The undersigned agrees to construct the aforescribed individual sewage disposal system in accordance with the provisions of Article XI of the Sanitary Code and regulations of the Amherst Board of Health. The undersigned further agrees not to place the system in operation until a Certificate of Compliance has been issued by this board of health.

Application Approved by [Signature]

Owner or builder

11-7-72 date
11-13-72 date

Application Disapproved for the following reasons:

BOARD OF HEALTH, AMHERST, MASSACHUSETTS

CERTIFICATE OF COMPLIANCE

THIS IS TO CERTIFY, That the individual Sewage Disposal System installed () or repaired () by at has been constructed in accordance with the provisions of

INSTALLER

Article XI of the State Sanitary Code as described in the application for Disposal Works Construction Permit No. dated

The issuance of this certificate shall not be construed as a guarantee that the system will function satisfactorily.

DATE Inspector

BOARD OF HEALTH, AMHERST, MASSACHUSETTS

DISPOSAL WORKS CONSTRUCTION PERMIT

No. 72-38 Permission is hereby granted GERALD D. McLELLAN to construct (✓) or repair () an Individual Sewage Disposal System at SHAYS ST as shown on the application for Disposal Works Construction Permit No. 72-38

This permit is issued with the understanding that future alterations or additions will be made if necessary. This permit shall not be construed as permission to create or maintain any sewage nuisance and in the issuance of this permit the Board of Health assumes no responsibility for the future operation or maintenance of the system.

DATE 11-13-72

[Signature] Board of Health

1000

1000

1000

1000

1000

1000

1000

1000

1000

1000

1000

1000

1000

1000

1000

1000

1000

1000

1000

BLAIR & ALICE LOW WILSON BLAIR
Book 1086, Page 334

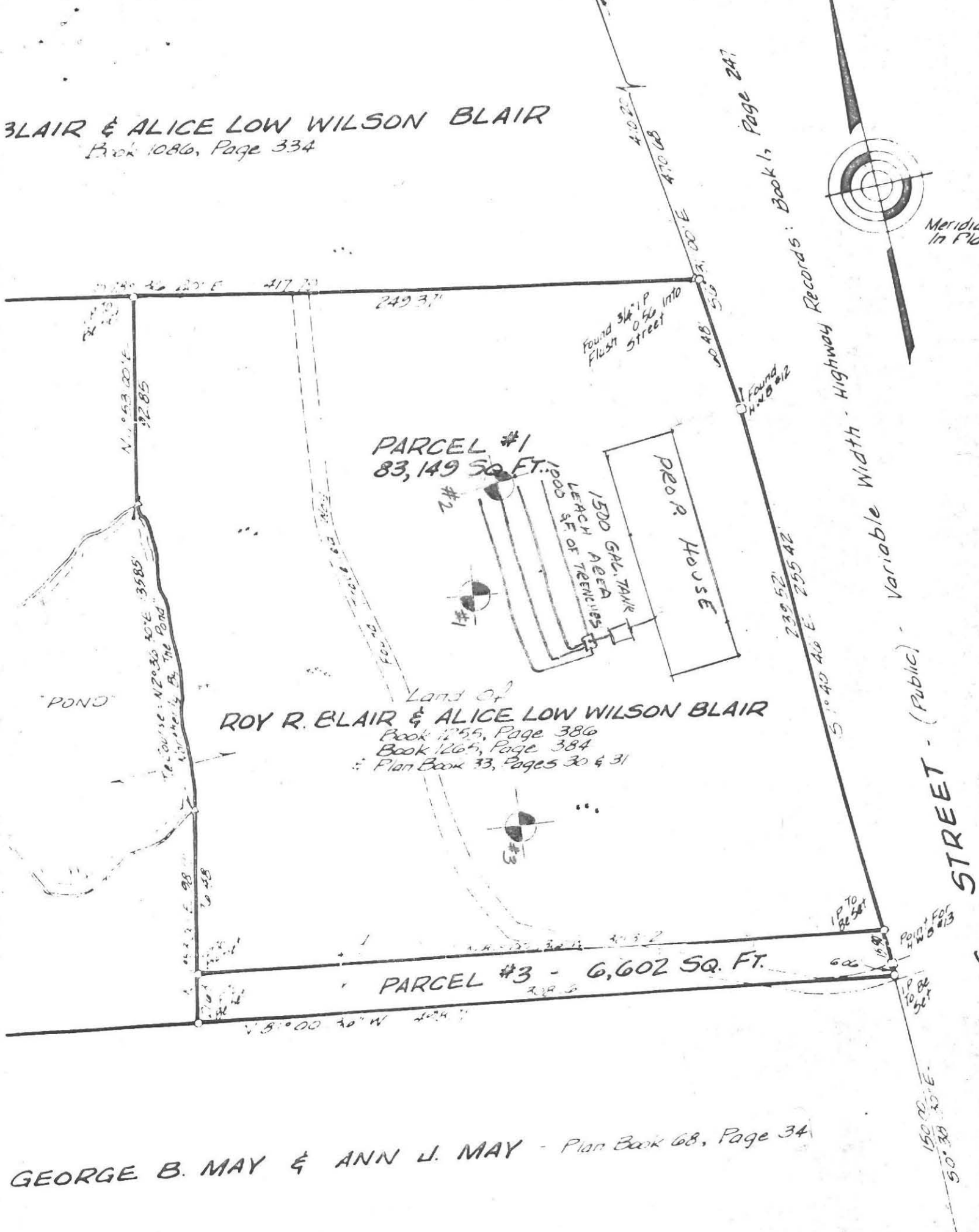

PARCEL #1
83,149 SQ. FT.

Land of
ROY R. BLAIR & ALICE LOW WILSON BLAIR
Book 1255, Page 386
Book 1264, Page 384
Plan Book 33, Pages 30 & 31

PARCEL #3 - 6,602 SQ. FT.

GEORGE B. MAY & ANN J. MAY - Plan Book 68, Page 34

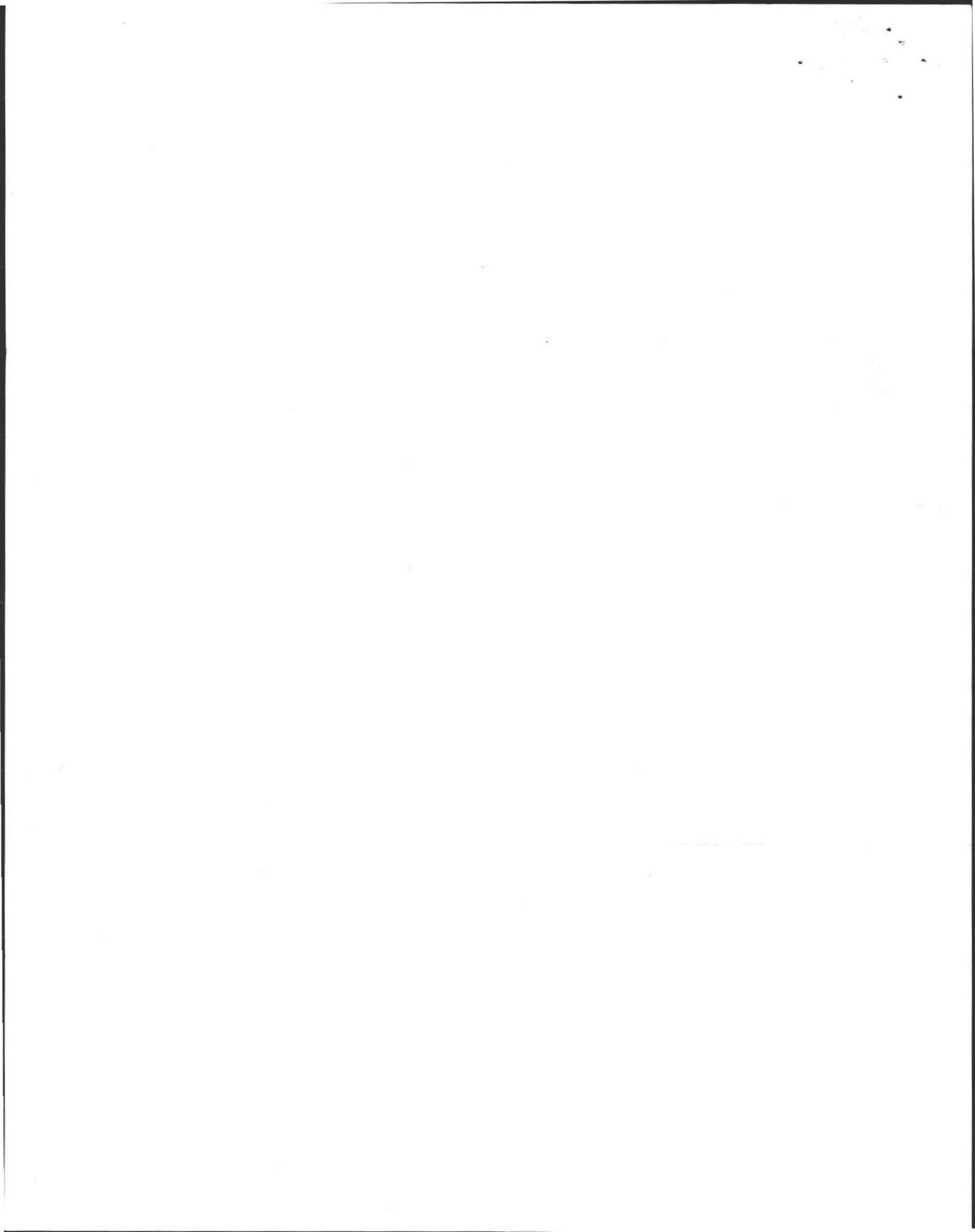

OBSERVATION PIT

REQUESTED BY: GERALD D. McLELLAN

DATE: 11/7/72

LOCATION: SHAY ST. AMHERST.

OBSERVER: J. HART

MAIL ADDRESS: 40 LEXINGTON ST HOLYOKE 01000

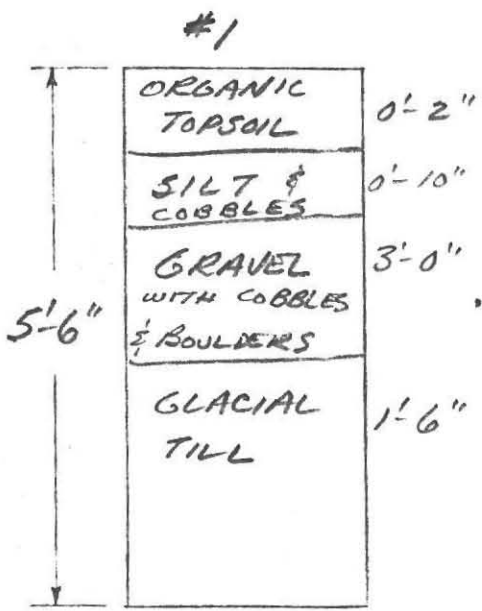

GROUND WATER NONE

PERC. RATE = 2 MIN./IN.

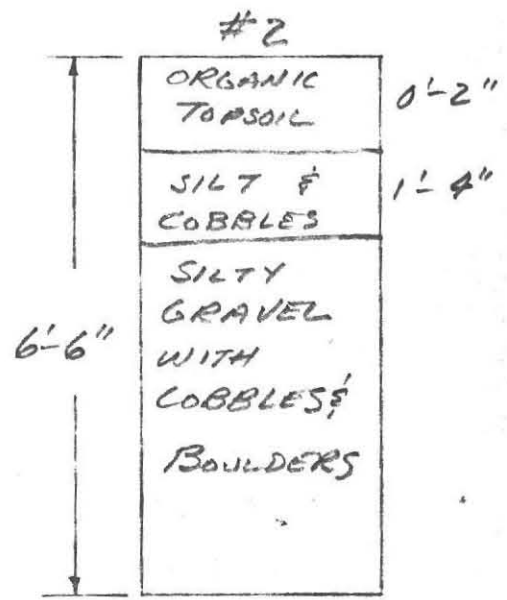

GROUND WATER NONE

PERC. RATE = 15 MIN./IN.

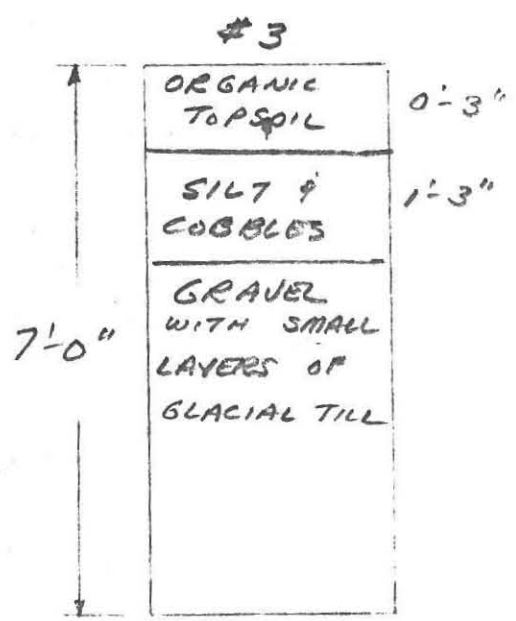

GROUND WATER NONE

PERC. RATE = 50+ MIN./IN.

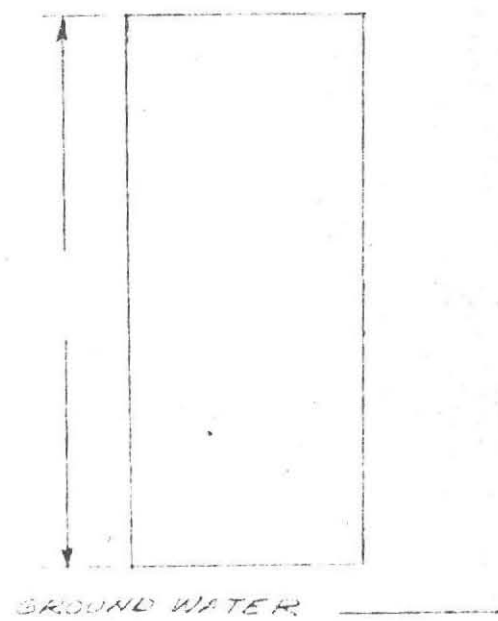

GROUND WATER _____

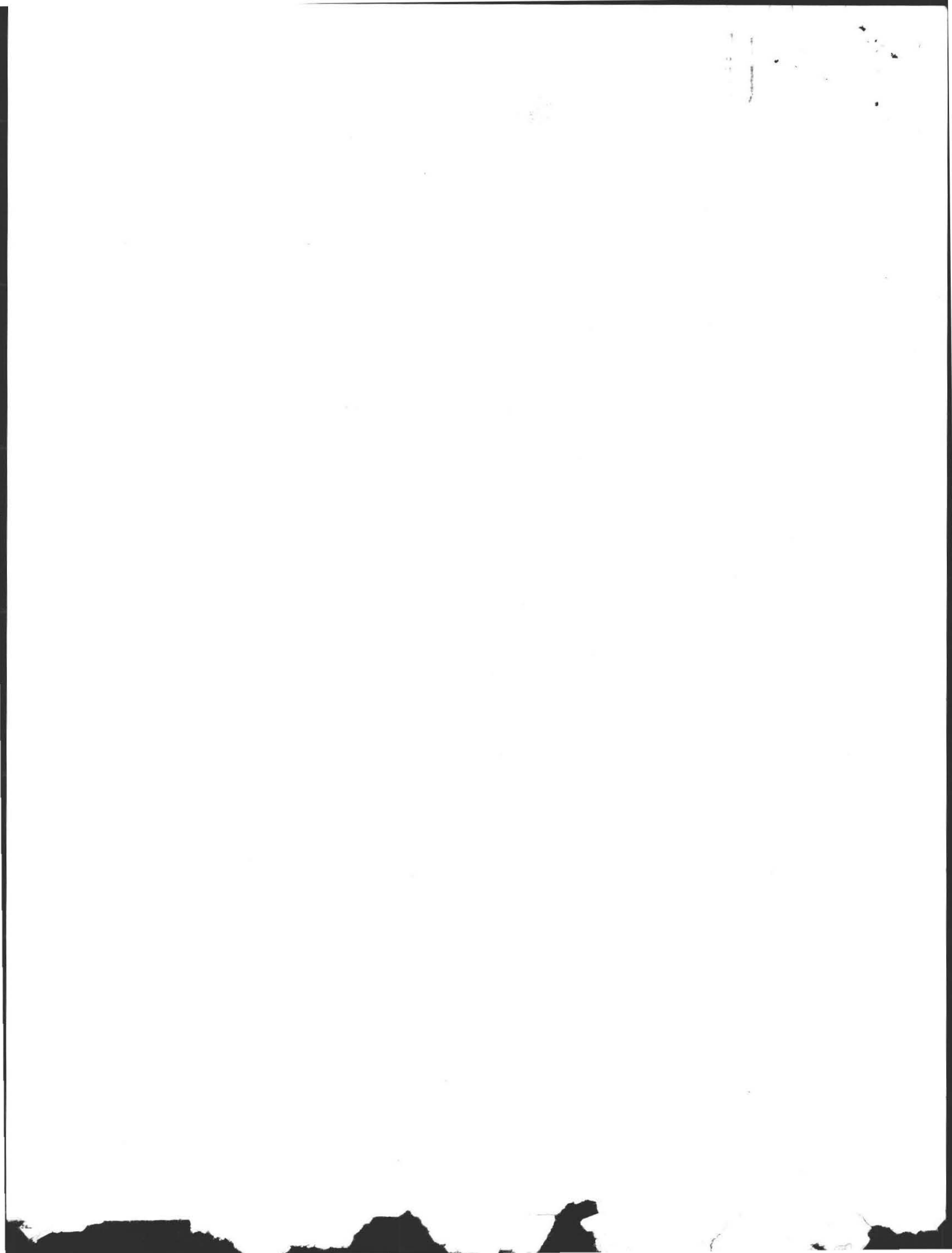

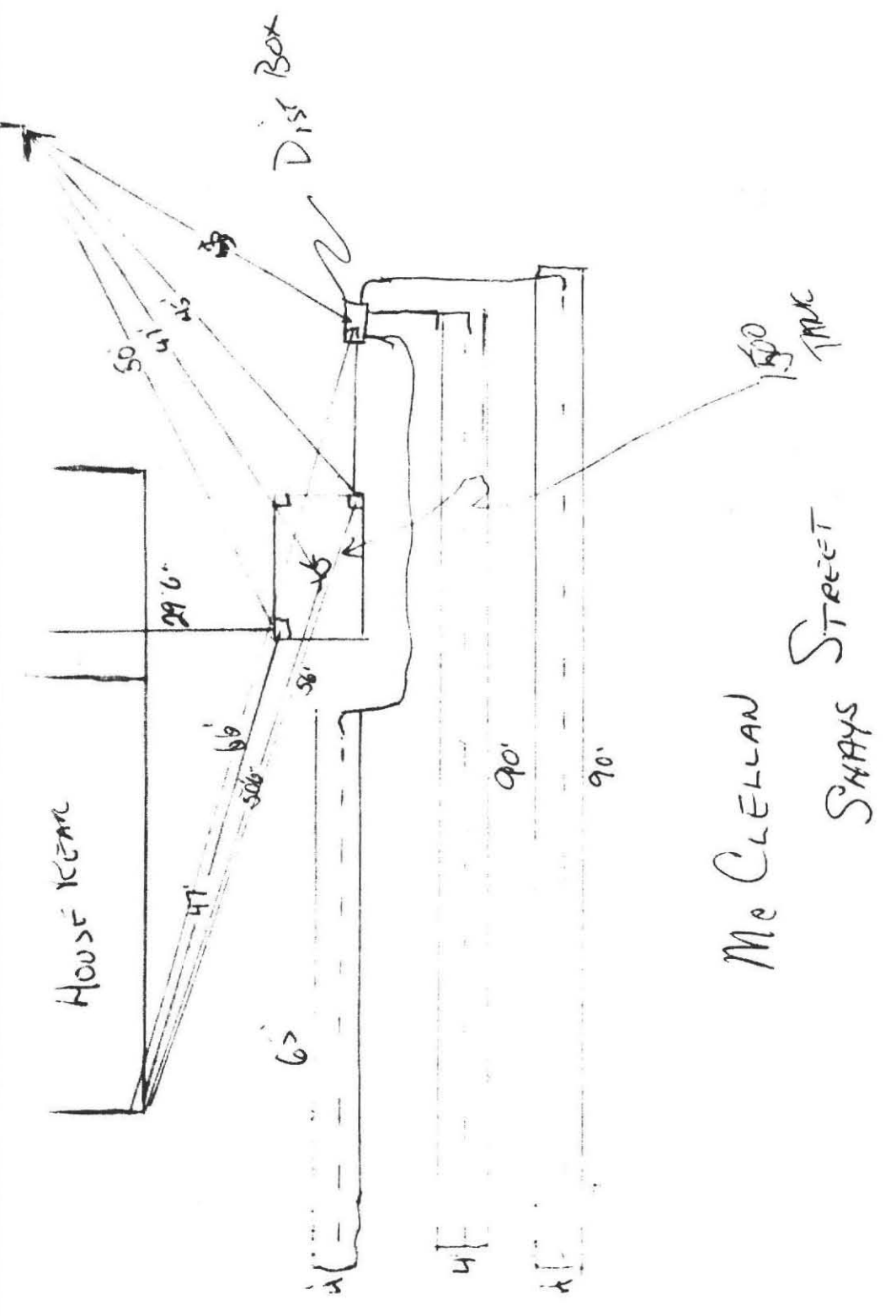

Mc CLELLAN
STAYS STREET

