

#53

**BOARD OF HEALTH, AMHERST, MASSACHUSETTS**  
**APPLICATION FOR DISPOSAL WORKS CONSTRUCTION PERMIT**

No. 69-7 Date July 8, 1969 Fee 3.00 Date Rec'd. July 8, 1969 By [Signature]

Application is hereby made for a permit to Construct (X) or Repair ( ) an Individual Sewage Disposal System at:

Location—Address 55 Mechanic St. or Lot No. \_\_\_\_\_

Owner William R. Doherty Address 65 Mechanic St.

Contractor William R. Doherty Address 65 Mechanic St.

Type of Building \_\_\_\_\_ Dimensions \_\_\_\_\_ Size Lot 30,000 sq plus

Dwelling—No. of Bedrooms 3 Expansion Attic ( ) Garbage Grinder (X)

Other \_\_\_\_\_ No. of persons \_\_\_\_\_ Showers ( )

Other fixtures \_\_\_\_\_

Town Water? Yes Type of Well \_\_\_\_\_

Design Flow 25 gallons per person per day. Total daily flow 450 gallons

Septic Tank—Liquid capacity 1800 gallons Dimensions: L \_\_\_\_\_ W \_\_\_\_\_ D \_\_\_\_\_

Disposal Trench—No. \_\_\_\_\_ Width \_\_\_\_\_ Total Length \_\_\_\_\_ Total leaching area \_\_\_\_\_ sq. ft.

Disposal Bed—No. 1 Diameter 18 Depth below inlet 30-40 Total leaching area 450 sq. ft.

Dry Well—No. \_\_\_\_\_ Diameter \_\_\_\_\_ Depth below inlet \_\_\_\_\_ Dimensions: \_\_\_\_\_ x \_\_\_\_\_

Other: Distribution box ( ) No. \_\_\_\_\_ Dosing tank ( )

(Depth of Soil Line Below finished grade at foundation \_\_\_\_\_)

Percolation Test Results Performed by \_\_\_\_\_ Date \_\_\_\_\_

Test Pit No. 1 \_\_\_\_\_ minutes per inch Depth of Test Pit \_\_\_\_\_

Test Pit No. 2 \_\_\_\_\_ minutes per inch Depth of Test Pit \_\_\_\_\_

Description of Soil GRAVEL Depth to Ground Water Not Found 12'

Will disposal area be filled? No Cut down? No

(On reverse side or separate sheet, show plot plan with building. Include dimensions, distances from all boundaries. Show location of wells, streams, ledge, large trees, etc.)

AGREEMENT: The undersigned agrees to construct the aforescribed individual sewage disposal system in accordance with the provisions of Article XI of the Sanitary Code and regulations of the Amherst Board of Health. The undersigned further agrees not to place the system in operation until a Certificate of Compliance has been issued by this board of health.

Application Approved by [Signature] William R. Doherty 6/3/69  
 Owner or builder date  
 Application Disapproved for the following reasons: \_\_\_\_\_ date

**BOARD OF HEALTH, AMHERST, MASSACHUSETTS**  
**CERTIFICATE OF COMPLIANCE**

THIS IS TO CERTIFY, That the individual Sewage Disposal System installed ( ) or repaired ( ) by \_\_\_\_\_ at \_\_\_\_\_ has been constructed in accordance with the provisions of

INSTALLER  
 Article XI of the State Sanitary Code as described in the application for Disposal Works Construction Permit No. \_\_\_\_\_ dated \_\_\_\_\_

The issuance of this certificate shall not be construed as a guarantee that the system will function satisfactorily.

DATE \_\_\_\_\_ Inspector \_\_\_\_\_

**BOARD OF HEALTH, AMHERST, MASSACHUSETTS**  
**DISPOSAL WORKS CONSTRUCTION PERMIT**

No. 69-7  
 Permission is hereby granted Wm. R. Doherty to construct (X) or repair ( ) an Individual Sewage Disposal System at 55 MECHANIC ST as shown on the application for Disposal Works Construction Permit No. 69-7

This permit is issued with the understanding that future alterations or additions will be made if necessary. This permit shall not be construed as permission to create or maintain any sewage nuisance and in the issuance of this permit the Board of Health assumes no responsibility for the future operation or maintenance of the system.

DATE July 8, 1969 [Signature]  
 Board of Health

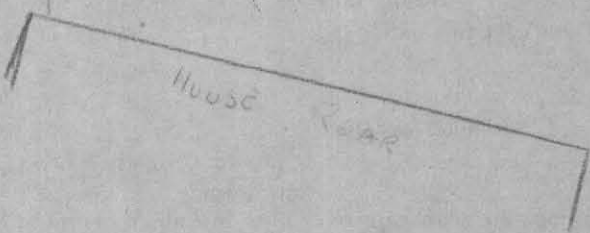
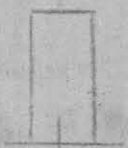
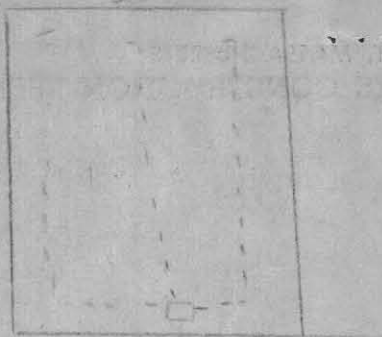

MECHANIC ST

#55

BOARD OF HEALTH, AMHERST, MASSACHUSETTS  
APPLICATION FOR DISPOSAL WORKS CONSTRUCTION PERMIT

No. 73-28 Date 5/4/73 Fee \$3.00 Date Rec'd. 5/8/73 By DGF

Application is hereby made for a permit to Construct (X) or Repair ( ) an Individual Sewage Disposal System at:

Location—Address Mechanic St or Lot No. \_\_\_\_\_  
Owner Wm. R. Doherty Address 55 Mechanic St.  
Contractor Wm. R. Doherty Address 55 Mechanic St.  
Type of Building Frame Home Dimensions 30' x 50' Size Lot 150' x 215'  
Dwelling—No. of Bedrooms 3 Expansion Attic (X) Garbage Grinder (X) yes  
Other \_\_\_\_\_ No. of persons 4 Showers ( ) \_\_\_\_\_  
Other fixtures \_\_\_\_\_  
Town Water? YES Type of Well \_\_\_\_\_

Design Flow 50 gallons per person per day. Total daily flow 300 gallons  
Septic Tank—Liquid capacity 1200 gallons Dimensions: L \_\_\_\_\_ W \_\_\_\_\_ D \_\_\_\_\_  
Disposal Trench—No. 2 Width 3.0 Total Length 64 Total leaching area 384 sq. ft.  
Disposal Bed—No. 1 Diameter 10 x 40 Depth below inlet \_\_\_\_\_ Total leaching area 400 sq. ft.  
Dry Well—No. \_\_\_\_\_ Diameter \_\_\_\_\_ Depth below inlet \_\_\_\_\_ Dimensions: \_\_\_\_\_ x \_\_\_\_\_ x \_\_\_\_\_  
Other: Distribution box (X) No. \_\_\_\_\_ Dosing tank ( ) \_\_\_\_\_

(Depth of Soil Line Below finished grade at foundation 1 mile J. Hubler)  
Percolation Test Results Performed by Miles J. Hubler PE Date 5/3/73  
Test Pit No. 1 2 minutes per inch Depth of Test Pit 7.0'  
Test Pit No. 2 \_\_\_\_\_ minutes per inch Depth of Test Pit \_\_\_\_\_  
Description of Soil clean loose sand Depth to Ground Water 5.0  
Will disposal area be filled? No Cut down? No  
(On reverse side or separate sheet, show plot plan with building. Include dimensions, distances from all boundaries. Show location of wells, streams, ledge, large trees, etc.)

AGREEMENT: The undersigned agrees to construct the aforescribed individual sewage disposal system in accordance with the provisions of Article XI of the Sanitary Code and regulations of the Amherst Board of Health. The undersigned further agrees not to place the system in operation until a Certificate of Compliance has been issued by this board of health.

Keeps system High -  
Application Approved by William R. Doherty Owner or builder Date 5/4/73  
C. D. Doherty Date 5-9-73

Application Disapproved for the following reasons:

BOARD OF HEALTH, AMHERST, MASSACHUSETTS  
CERTIFICATE OF COMPLIANCE

THIS IS TO CERTIFY, That the individual Sewage Disposal System installed ( ) or repaired ( ) by \_\_\_\_\_ at \_\_\_\_\_ has been constructed in accordance with the provisions of \_\_\_\_\_ INSTALLER Article XI of the State Sanitary Code as described in the application for Disposal Works Construction Permit No. \_\_\_\_\_ dated \_\_\_\_\_ The issuance of this certificate shall not be construed as a guarantee that the system will function satisfactorily.  
DATE \_\_\_\_\_ Inspector \_\_\_\_\_

BOARD OF HEALTH, AMHERST, MASSACHUSETTS  
DISPOSAL WORKS CONSTRUCTION PERMIT

No. 73-28  
Permission is hereby granted Wm. R. Doherty to construct (X) or repair ( ) an Individual Sewage Disposal System at Lot Mechanic St as shown on the application for Disposal Works Construction Permit No. 73-28

This permit is issued with the understanding that future alterations or additions will be made if necessary. This permit shall not be construed as permission to create or maintain any sewage nuisance and in the issuance of this permit the Board of Health assumes no responsibility for the future operation or maintenance of the system.

DATE MAY 9, 1973 Board of Health

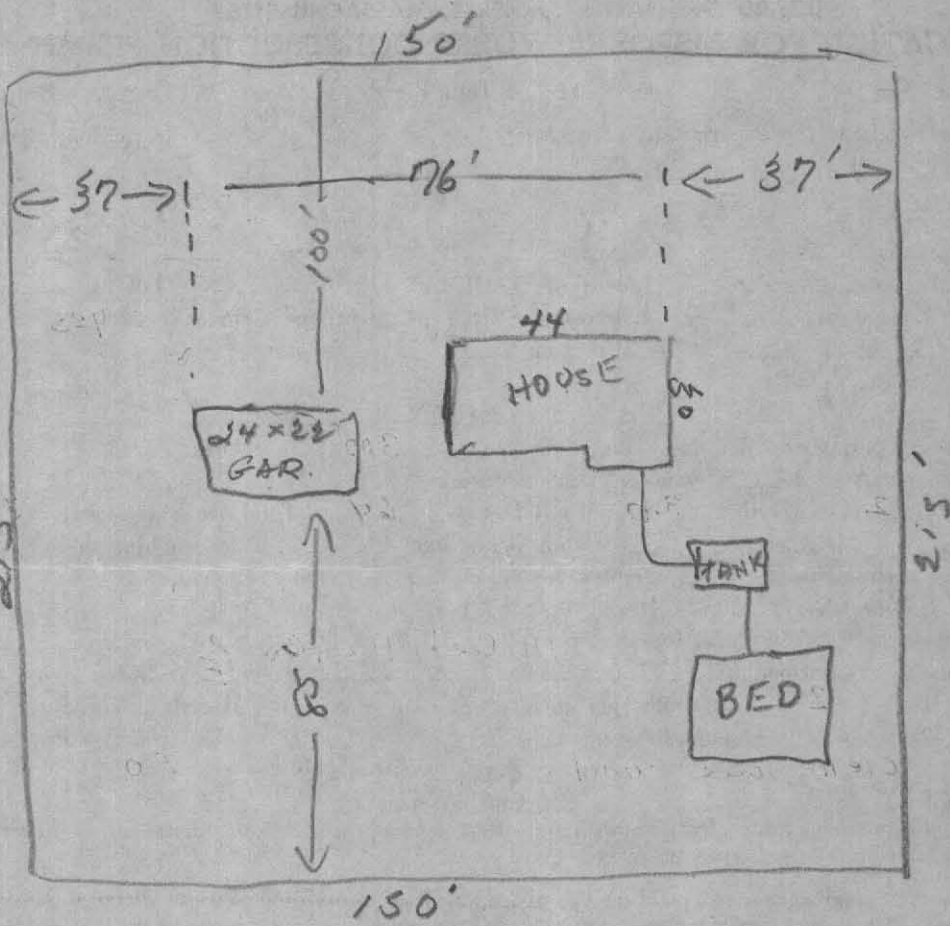

MECHANIC ST.

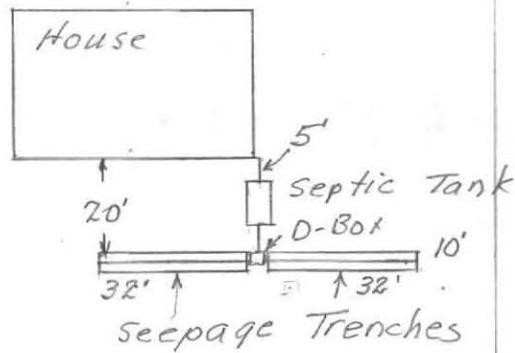

To Amherst Center      Mechanic St.

Note: See "The State Sanitary Code" Art. XI for trench specifications.

Plan Showing Sanitary Sewage Disposal for Lot on Mechanic St.

1" = 40'

5-3-73

by M.J. Hubler

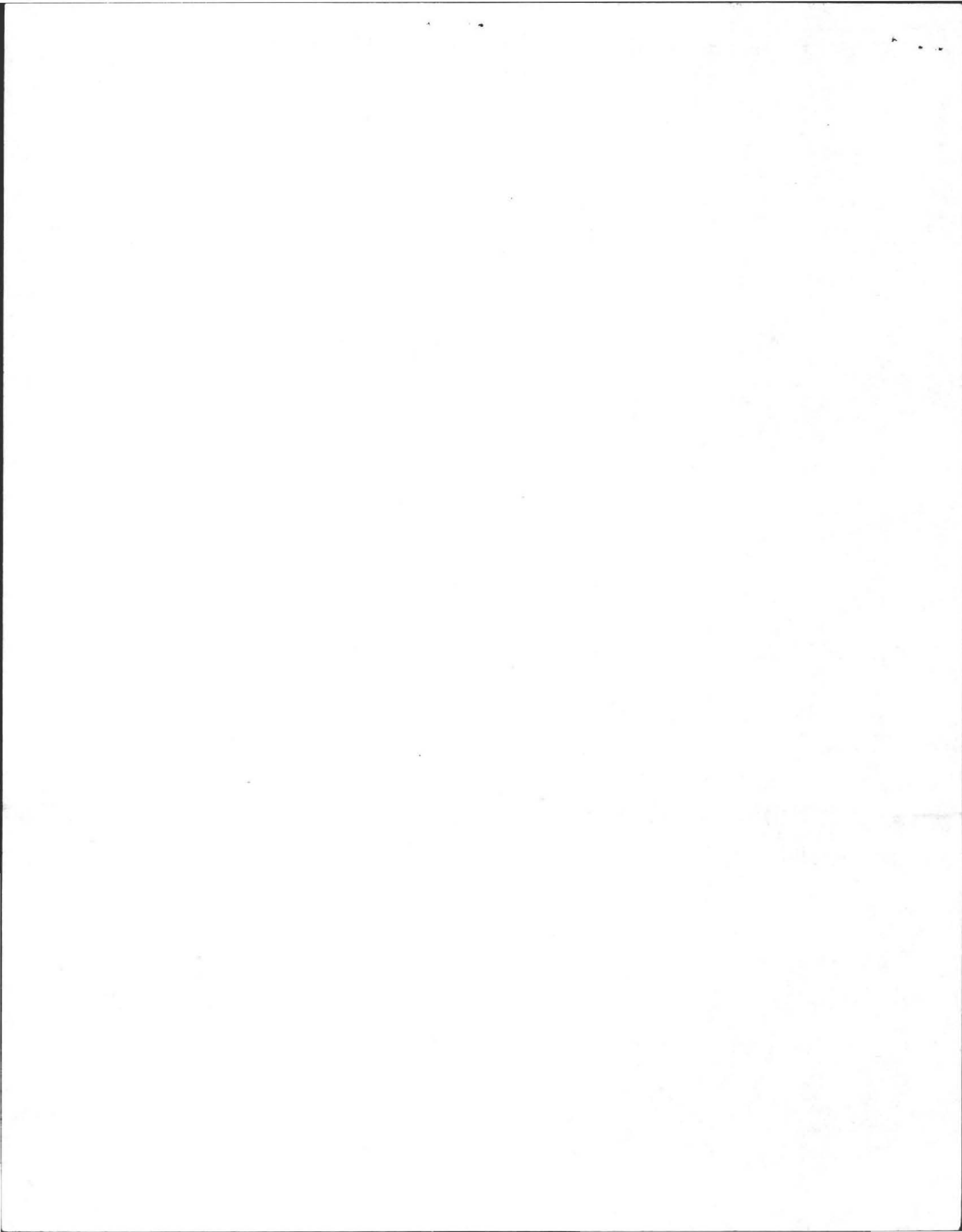

# DEEP SOIL LOGS

OWNER William Doherty

DATE 4-21-73

LOCATION Mechanic St

OBSERVER Drake

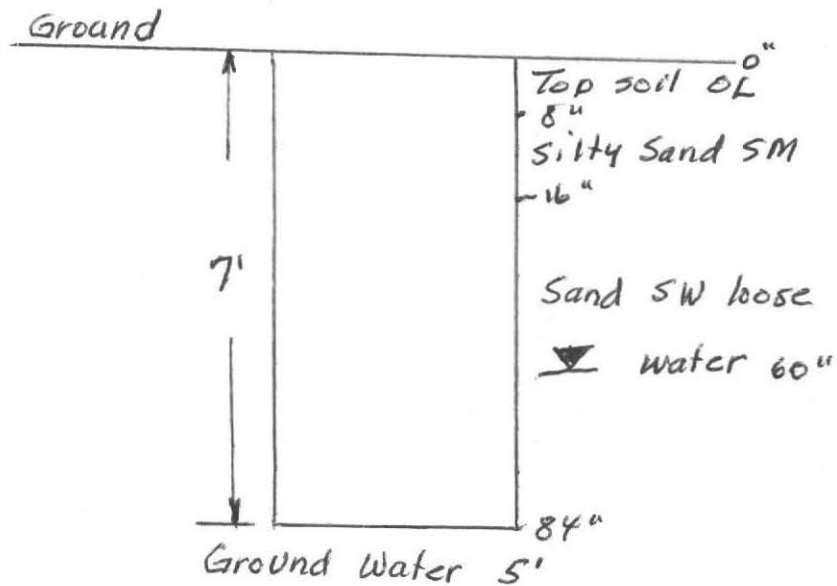

1. THE STATE OF TEXAS

COUNTY OF ...

LOCATION ...

...



...

...