

84-20

#8

FEE \$90

THE COMMONWEALTH OF MASSACHUSETTS

BOARD OF HEALTH

Town OF Amherst, Mass.

Application for Disposal Works Construction Permit

Application is hereby made for a Permit to Construct (x) or Repair ( ) an Individual Sewage Disposal System at:

Indian Pipe Lane Lot # 34
Location - Address or Lot No.
Plantation Valley Homes, Inc. Box 7, Florence, Ma. 01060
Owner Address
Edward B. Savally & Son, Inc. 541 Ryan Rd., Florence, MA 01060
Installer Address

Type of Building
Dwelling - No. of Bedrooms 3 Expansion Attic ( ) Garbage Grinder (x)
Other - Type of Building Frame No. of persons Max. 6 Showers ( ) - Cafeteria ( )
Other fixtures

Design Flow 55 gallons per person per day. Total daily flow 330 gallons.
Septic Tank - Liquid capacity 1500 gallons Length 10' Width 6' Diameter Depth 5'
Disposal Trench - No. Width Total Length Total leaching area sq. ft.
Seepage Pit No. 2 Diameter 7.50 gal Depth below inlet 2 1/2' Total leaching area 800 sq. ft.

Other Distribution box (x) Dosing tank ( )
Percolation Test Results Performed by Fred Filios R.S. Date 5/84
Test Pit No. 1 2 minutes per inch Depth of Test Pit 32" Depth to ground water None
Test Pit No. 2 ----- minutes per inch Depth of Test Pit 132" Depth to ground water None

Description of Soil 0" to 6" topsoil - 6" to 18" subsoil - 18" to 36" mixed gravel - 36" to 114" gravel - 114" to 132" sand - no water at 132"

Nature of Repairs or Alterations - Answer when applicable
MAY USE 1-1000 GAL TANK

Agreement:
The undersigned agrees to install the aforescribed Individual Sewage Disposal System in accordance with the provisions of TITLE 5 of the State Sanitary Code - The undersigned further agrees not to place the system in operation until a Certificate of Compliance has been issued by the board of health.

Signed ORIGINAL SIGNED BY 6/1/84
Application Approved By [Signature] 1-BLAUERT 6-7-84
Date

Application Disapproved for the following reasons:

Permit No. 84-20 Issued 6-7-84
Date

THE COMMONWEALTH OF MASSACHUSETTS

BOARD OF HEALTH

OF

Certificate of Compliance

THIS IS TO CERTIFY, That the Individual Sewage Disposal System constructed ( ) or Repaired ( ) by
Installer

at
has been installed in accordance with the provisions of TITLE 5 of The State Sanitary Code as described in the application for Disposal Works Construction Permit No. dated

THE ISSUANCE OF THIS CERTIFICATE SHALL NOT BE CONSTRUED AS A GUARANTEE THAT THE SYSTEM WILL FUNCTION SATISFACTORY.

DATE Inspector

THE COMMONWEALTH OF MASSACHUSETTS

BOARD OF HEALTH

No. 84-20 TOWN OF Amherst FEE \$90

Disposal Works Construction Permit

Permission is hereby granted Plantation Valley Homes
to Construct (X) or Repair ( ) an Individual Sewage Disposal System
at No. Lot 34 Amherst Mass Indian Pipe Lane
Street

as shown on the application for Disposal Works Construction Permit No. 84-20 Dated 6-7-84

DATE 6-7-84 [Signature] Board of Health

CHECK OR FILL IN WHERE APPLICABLE

BISIEWICZ  
INDIA PIRE

256-8468

744-3399

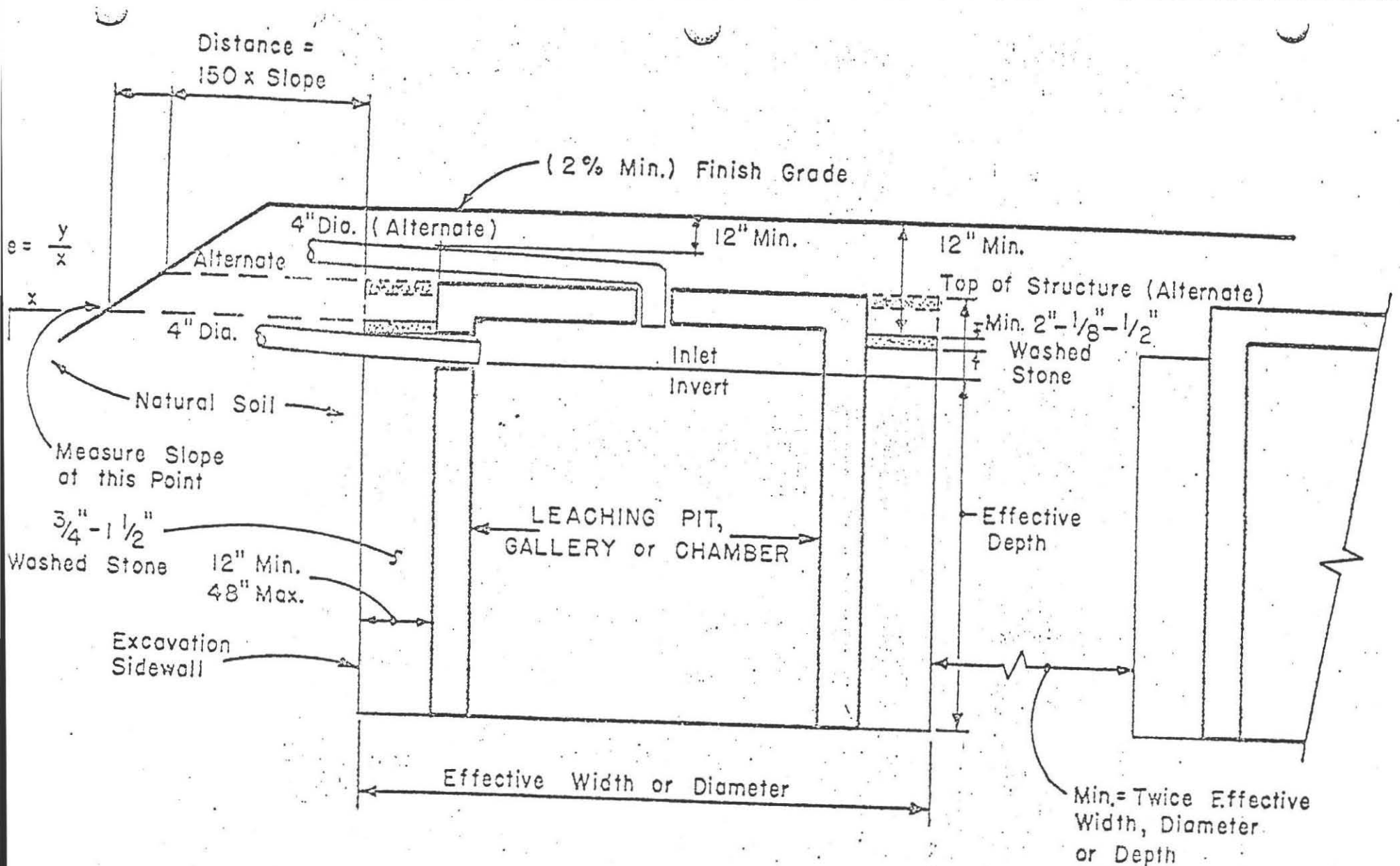

**LEACHING PITS, GALLERIES, CHAMBERS**

No Scale

Illustration A

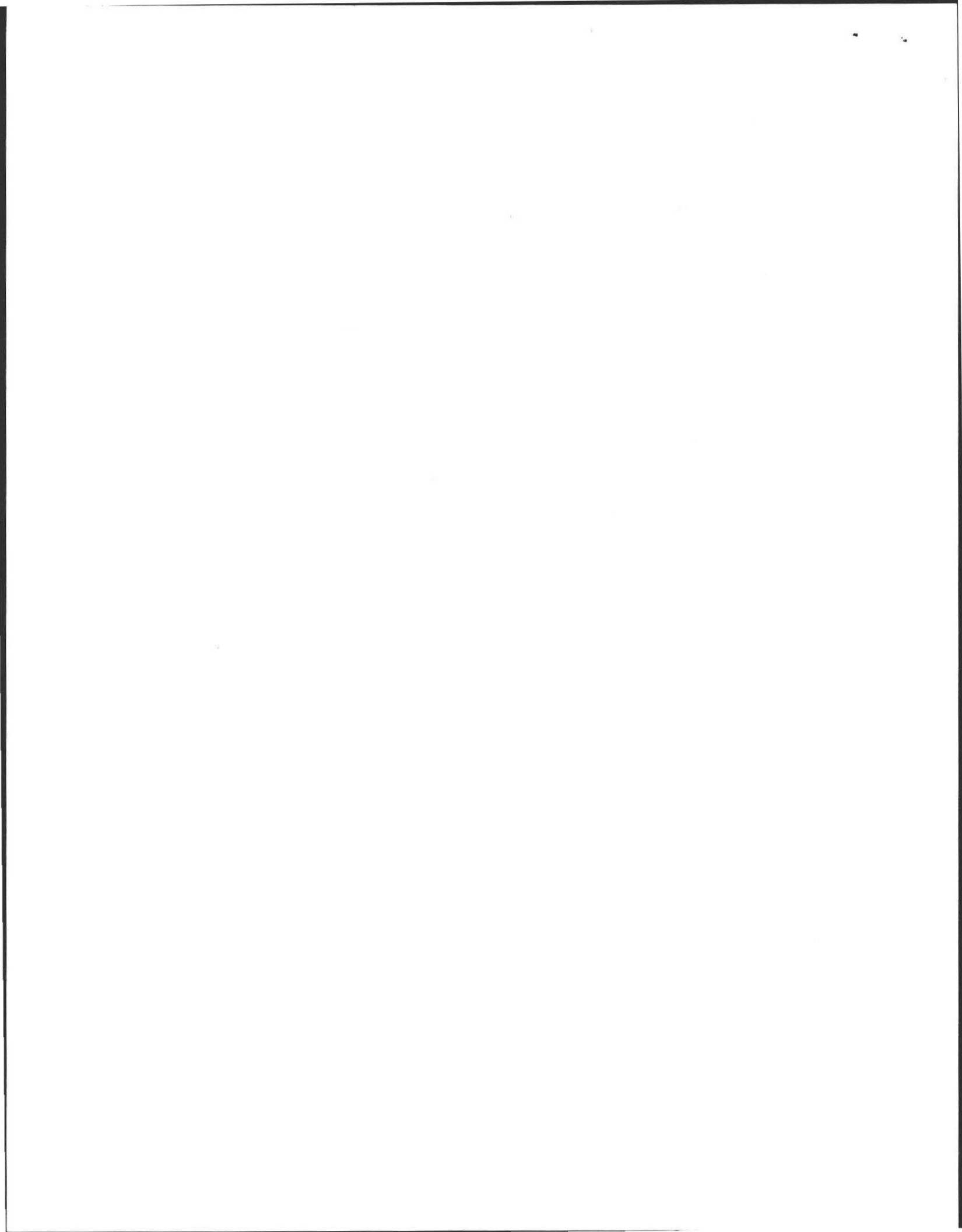

JOHN A. BRICKETT, R.S.  
 19 SUMMER STREET  
 GREENFIELD, MASS. 01301

*John A. Brackett R.S.*  
 6/1/84

NO SCALE

LOT # 3A

38,596 Sq. FT

DEEP TEST LOG

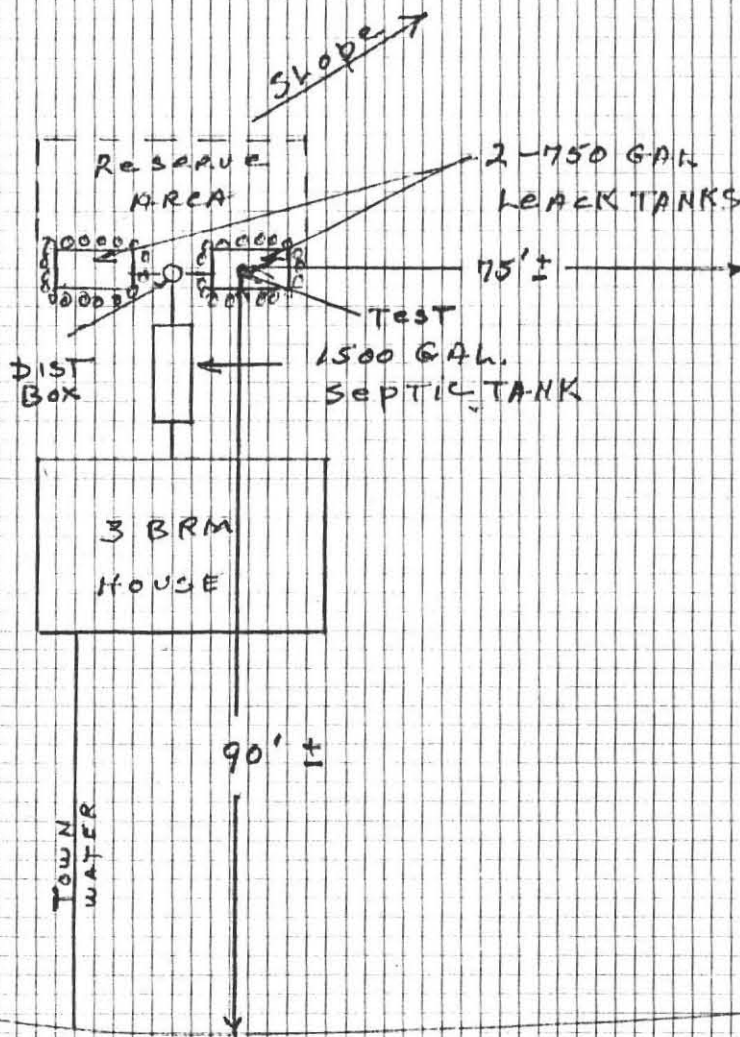

TOP SOIL	6"
SUB-SOIL	18"
MIXED GRAVEL	
GRAVEL	
	114"
SAND	132"
NO WATER	

INDIAN PIPE LANE

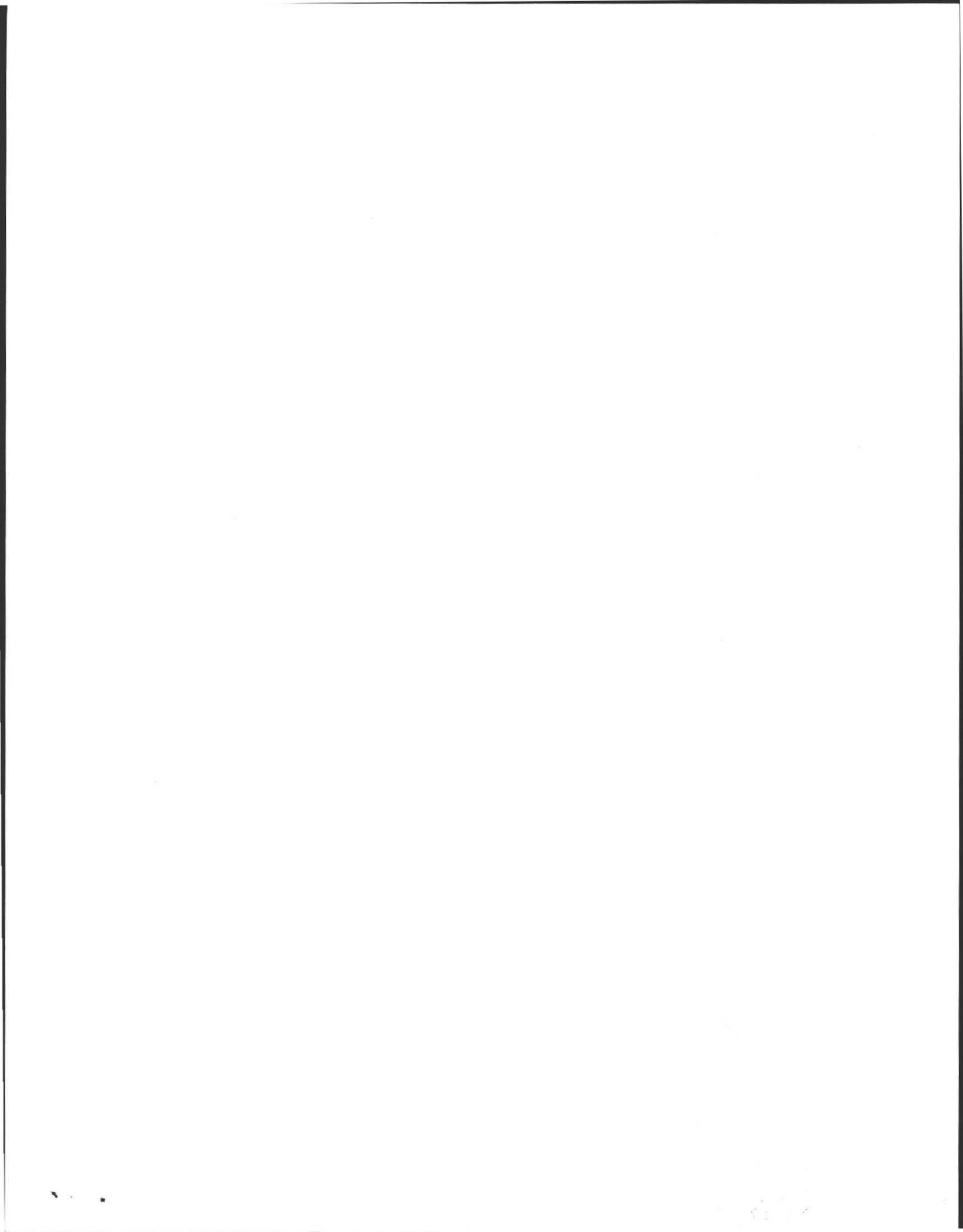

37 Indian Pipe





No. 84-20

#31

FEE \$90

THE COMMONWEALTH OF MASSACHUSETTS

BOARD OF HEALTH

Town OF Amherst, Mass.

Application for Disposal Works Construction Permit

Application is hereby made for a Permit to Construct (X) or Repair ( ) an Individual Sewage Disposal System at:

37 Indian Pipe Lane Lot # 34  
Plantation Valley Homes, Inc. or Lot No. Box 7, Florence, Ma. 01060  
EDWARD B LAVALLEY & SONS, INC. Address 541 RYAN RD, FLORENCE, MA 01060  
Installer

Type of Building  
Dwelling — No. of Bedrooms 3 Expansion Attic ( )  
Other — Type of Building Frame No. of persons Max. 6 Showers ( ) — Cafeteria ( )  
Other fixtures

Design Flow 55 gallons per person per day. Total daily flow 330 gallons.  
Septic Tank — Liquid capacity 1500 gallons Length 10' Width 6' Diameter 5' Depth 5'  
Disposal Trench — No. 2 Width 750 gal Total Length 2 1/2' Total leaching area 800 sq. ft.  
Seepage Pit No. 2 Diameter 750 gal Depth below inlet 2 1/2' Total leaching area 800 sq. ft.

Other Distribution box (X) Dosing tank ( )  
Percolation Test Results Performed by Fred Filios R.S. Date 5/84  
Test Pit No. 1 2 minutes per inch Depth of Test Pit 32" Depth to ground water None  
Test Pit No. 2 ----- minutes per inch Depth of Test Pit 132" Depth to ground water None

Description of Soil 0" to 6" topsoil - 6" to 18" subsoil - 18" to 36" mixed gravel - 36" to 114" gravel - 114" to 132" sand - no water at 132".

Nature of Repairs or Alterations — Answer when applicable

Agreement:  
The undersigned agrees to install the aforescribed Individual Sewage Disposal System in accordance with the provisions of TITLE 5 of the State Sanitary Code — The undersigned further agrees not to place the system in operation until a Certificate of Compliance has been issued by the board of health.

Signed Plantation Valley Homes, Inc Date 6/1/84  
Application Approved By [Signature] Date 6-7-84

Application Disapproved for the following reasons:

Permit No. 84-20 Issued 6-7-84 Date

THE COMMONWEALTH OF MASSACHUSETTS

BOARD OF HEALTH

OF

Certificate of Compliance

THIS IS TO CERTIFY, That the Individual Sewage Disposal System constructed ( ) or Repaired ( ) by

at  
has been installed in accordance with the provisions of TITLE 5 of The State Sanitary Code as described in the application for Disposal Works Construction Permit No. dated

THE ISSUANCE OF THIS CERTIFICATE SHALL NOT BE CONSTRUED AS A GUARANTEE THAT THE SYSTEM WILL FUNCTION SATISFACTORY.

DATE Inspector

THE COMMONWEALTH OF MASSACHUSETTS

BOARD OF HEALTH

Town OF Amherst

No. 84-20

FEE \$90

Disposal Works Construction Permit

Permission is hereby granted Plantation Valley Homes  
to Construct (X) or Repair ( ) an Individual Sewage Disposal System Indian Pipe Lane  
at No. Lot 34 Amherst Woods Street  
as shown on the application for Disposal Works Construction Permit No. 84-20 Dated 6-7-84

DATE 6-7-84 Board of Health

CHECK OR FILL IN WHERE APPLICABLE

1000

1000

1

1000

1000

1000



JOHN A. BRICKETT, R.S.  
 19 SUMMER STREET  
 GREENFIELD, MASS. 01301

*John A. Brackett R.S.*  
 6/1/84

NO SCALE

Lot # 3A  
 38,596 Sq. FT

DEEP TEST LOG

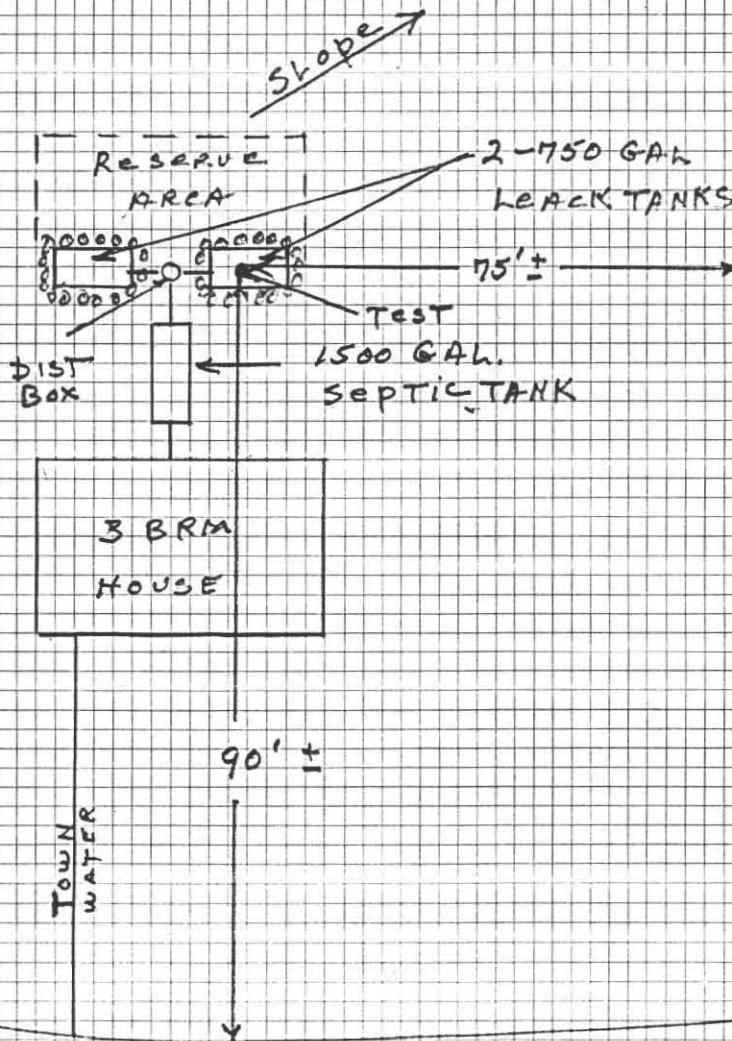

Top SOIL	6"
SUB-SOIL	18"
MIXED GRAVEL	
GRAVEL	
	114"
SAND	132"
NO WATER	

INDIAN PIPE LANE

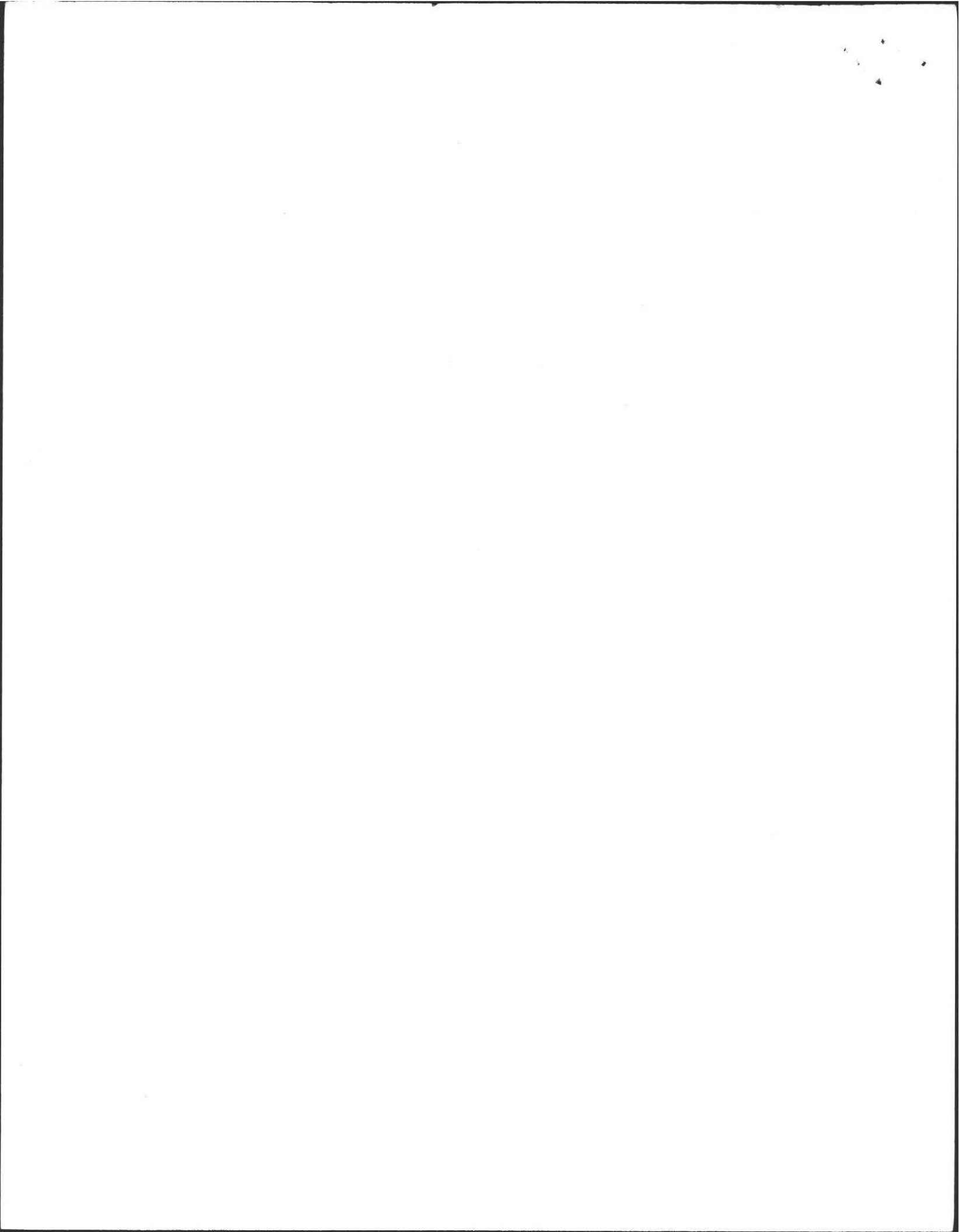

BOARD OF HEALTH

TOWN OF AMHERST, MASSACHUSETTS

LOT # 34 INDIAN PIPE LA

Important Information Regarding Your Private Sewage Disposal System

DISPLAY THIS DOCUMENT IN A PROMINENT PLACE

Owner PLANTATION VALLEY HOMES Address Box 7 FERRISBURGH
Installer LAVALLEY & SONS Address RYAN RD FERRISBURGH
Date Installation Inspected and Approved 8-1-84
Description of System: Tank Capacity: 1500

Leach Field ( ) Bed ( ) Seepage Pits (X) Square Feet: 450
Garbage Grinder Yes (X) No ( ) No. Bedrooms: 3 No. People 6

AS - BUILT PLAN:

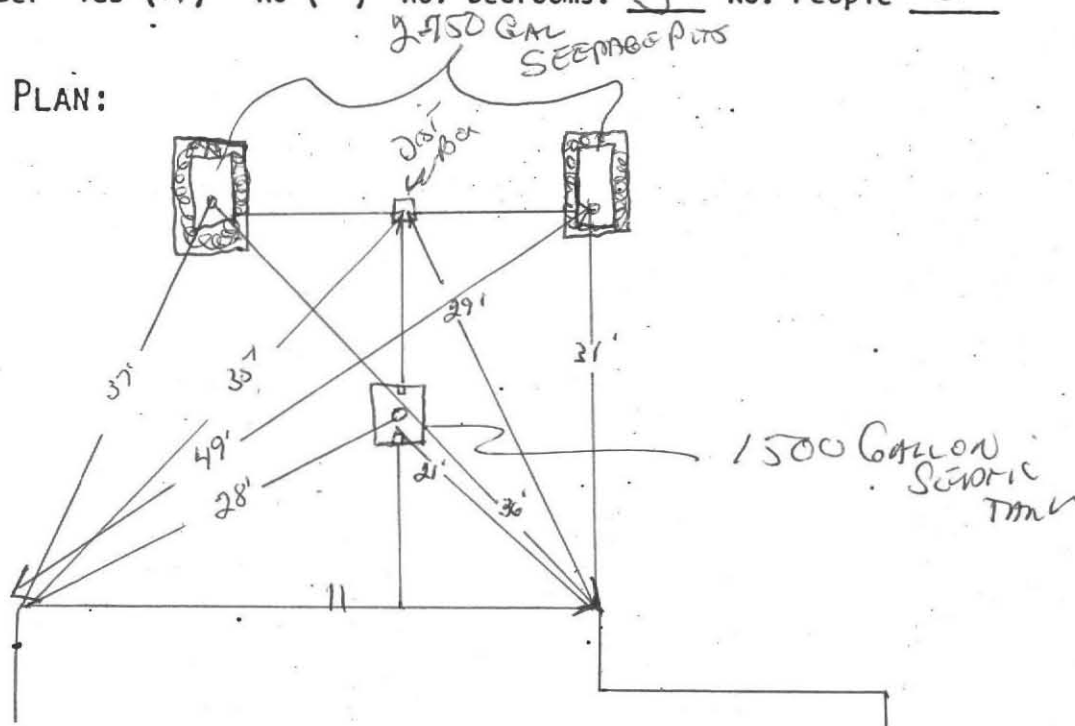

PROPER MAINTENANCE OF YOUR PRIVATE SEWAGE DISPOSAL SYSTEM

- 1. This system must be inspected periodically and the tank pumped out at an interval not to exceed 3 years.
2. For your protection sanitary pumpers are licensed by the Amherst Board of Health.
3. Regular pumping is crucial to avoid early failure and costly repairs of the system.
4. DO NOT dispose into the system such items as rags, string, sanitary napkins, coffee grounds as they can cause it to clog and fail.
5. Further information can be obtained by contacting your Health Department at 253-7077.

