

130 IOWA Lane



#130

BOARD OF HEALTH, AMHERST, MASSACHUSETTS
APPLICATION FOR DISPOSAL WORKS CONSTRUCTION PERMIT

No. 73-89 Date 10/4/73 Fee \$3.00 Date Rec'd. 10/4/73 By DGF

Application is hereby made for a permit to Construct (X) or Repair () an Individual Sewage Disposal System at:

Location—Address 130 EDNA LANE or Lot No. 23-24

Owner GEORGE WILLIAMS Address 193 GLENWOOD RD. AMHERST

Contractor _____ Address _____

Type of Building Dwelling Dimensions _____ Size Lot 1.9 ACRES

Dwelling—No. of Bedrooms 4 Expansion Attic NO Garbage Grinder NO

Other _____ No. of persons _____ Showers ()

Other fixtures _____

Town Water? yes Type of Well _____

Design Flow 50 gallons per person per day. Total daily flow 400 gallons.

Septic Tank—Liquid capacity 1200 gallons Dimensions: L 10'0" W 5'4" D 4'10"

Disposal Trench—No. 1 Width 20 Total Length 30 Total leaching area 600 sq. ft.

Disposal Bed—No. _____ Diameter _____ Depth below inlet _____ Total leaching area _____ sq. ft.

Dry Well—No. _____ Diameter _____ Depth below inlet _____ Dimensions: _____ x _____ x _____

Other: Distribution box (X) No. _____ Dosing tank ()

(Depth of Soil Line Below finished grade at foundation _____)

Percolation Test Results Performed by R. B. Searles Amherst Huntley Assoc Date 9-26-73

Test Pit No. 1 .67 minutes per inch Depth of Test Pit 8'

Test Pit No. 2 _____ minutes per inch Depth of Test Pit _____

Description of Soil SANDY CLAYES Depth to Ground Water NONE

Will disposal area be filled? _____ Cut down? _____

(On reverse side or separate sheet, show plot plan with building. Include dimensions, distances from all boundaries. Show location of wells, streams, ledge, large trees, etc.)

AGREEMENT: The undersigned agrees to construct the aforescribed individual sewage disposal system in accordance with the provisions of Article XI of the Sanitary Code and regulations of the Amherst Board of Health. The undersigned further agrees not to place the system in operation until a Certificate of Compliance has been issued by this board of health.

Application Approved by [Signature] Owner or builder [Signature] date Oct 4, 1973

Application Disapproved for the following reasons: _____

BOARD OF HEALTH, AMHERST, MASSACHUSETTS
CERTIFICATE OF COMPLIANCE

THIS IS TO CERTIFY, That the individual Sewage Disposal System installed () or repaired () by _____ at _____ has been constructed in accordance with the provisions of

INSTALLER Article XI of the State Sanitary Code as described in the application for Disposal Works Construction Permit No. _____ dated _____

The issuance of this certificate shall not be construed as a guarantee that the system will function satisfactorily.

DATE _____ Inspector _____

BOARD OF HEALTH, AMHERST, MASSACHUSETTS
DISPOSAL WORKS CONSTRUCTION PERMIT

No. 73-89 Permission is hereby granted Geo. Williams to construct (X) or repair () an Individual Sewage Disposal System at LOT 23+24 EDNA LANE

as shown on the application for Disposal Works Construction Permit No. 73-89

This permit is issued with the understanding that future alterations or additions will be made if necessary. This permit shall not be construed as permission to create or maintain any sewage nuisance and in the issuance of this permit the Board of Health assumes no responsibility for the future operation or maintenance of the system.

DATE 10-4-73 Board of Health [Signature]

STATE OF TEXAS
COUNTY OF DALLAS

Know all men by these presents, that _____ of the County of _____ State of _____ do hereby certify that _____ of the County of _____ State of _____ is the true and correct owner of the _____ described in the _____ of _____ of _____ County, State of _____ and that the same is subject to a mortgage in favor of _____ of the County of _____ State of _____ in the amount of _____ Dollars (\$ _____) and that the same is being sold by _____ of the County of _____ State of _____ in accordance with the terms of the said mortgage.

Witness my hand and seal of office this _____ day of _____ 19____ at _____ City, State of _____.

Notary Public in and for the State of _____

OBSERVATION PIT

REQUESTED BY: GEORGE WILLIAMS

DATE: _____

LOCATION: LOTS 23 & 24, IDUNA LANE
AMHERST, MASS.

OBSERVER: RPB

MAIL ADDRESS: _____

LOTS 23 & 24

TEST #1

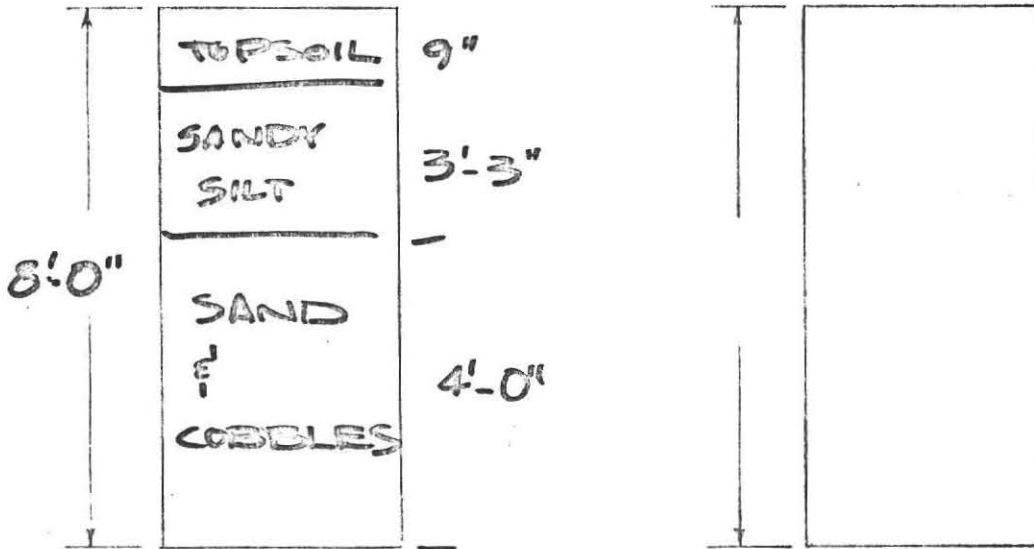

GROUND WATER NONE
PERC TEST = .67 MIN/IN

GROUND WATER _____

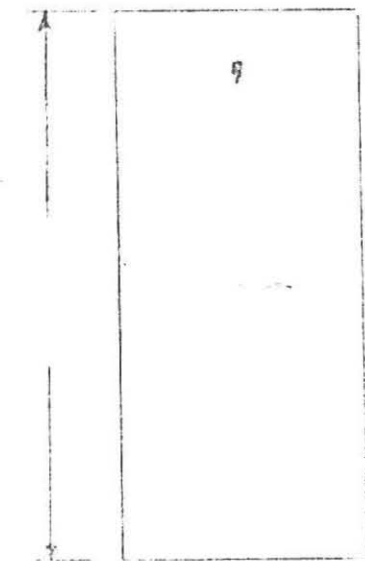

GROUND WATER _____

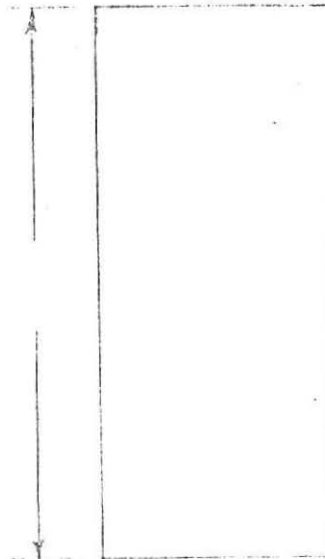

GROUND WATER _____

ALMER HUNTLEY, JR. & ASSOCIATES, INC.
 REGISTERED LAND SURVEYORS & CIVIL ENGINEERS
 238 BRIDGE STREET
 NORTHAMPTON, MASS.

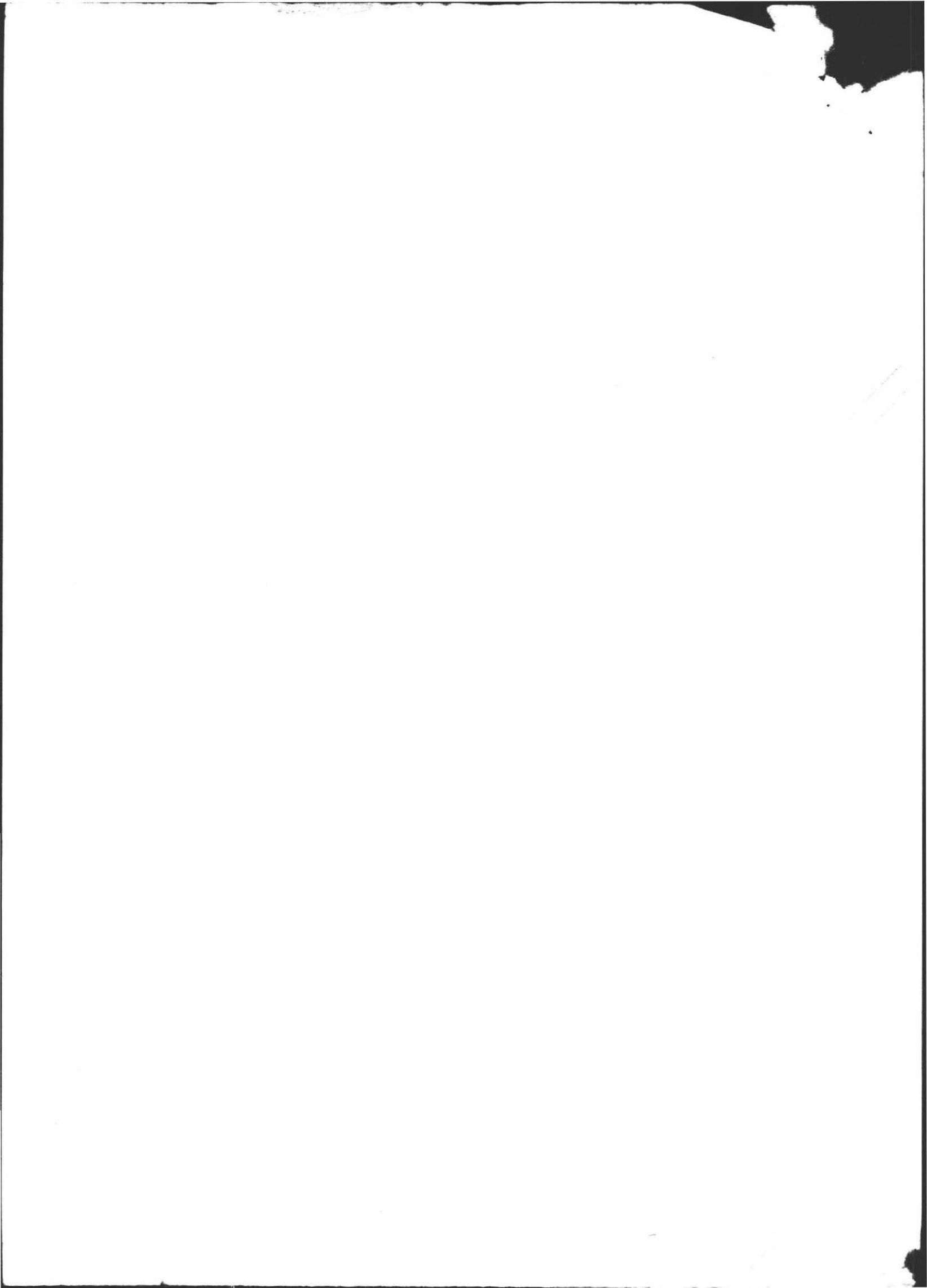

BOARD OF HEALTH

TOWN OF AMHERST, MASSACHUSETTS

Important Information Regarding Your Private Sewage Disposal System

DISPLAY THIS DOCUMENT IN A PROMINENT PLACE

Owner: GEORGE WILLIAMS Address LOT 23-24 TOWNHAWK

Installer HUBERT GREENE Address BELCHERTOWN

Date Installation Inspected and Approved Nov. 7, 1973

Description of System: Tank Capacity: 1250

Leach Field () Bed (X) Seepage Pit () Square Feet: 625

Garbage Grinder Yes (X) No () No. Bedrooms: 4 No. People 8

AS - BUILT PLAN:

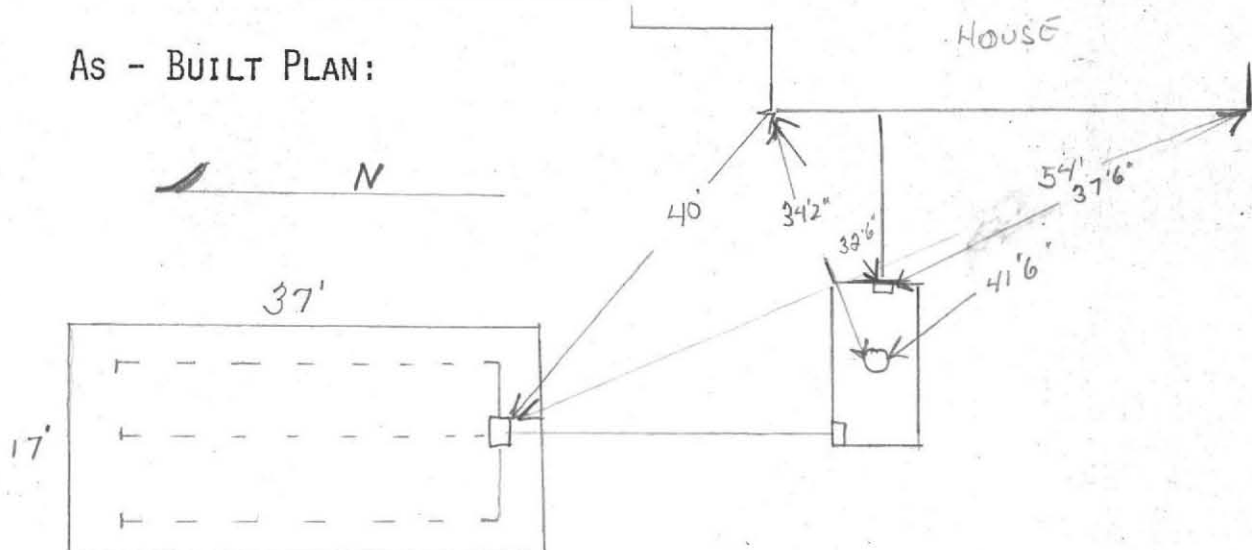

PROPER MAINTENANCE OF YOUR PRIVATE SEWAGE DISPOSAL SYSTEM

1. This system must be inspected periodically and the tank pumped out at an interval not to exceed 3 years.
2. For your protection sanitary pumpers are licensed by the Amherst Board of Health.
3. Regular pumping is crucial to avoid early failure and costly repairs of the system.
4. DO NOT dispose into the system such items as rags, string, sanitary napkins, coffee grounds as they can cause it to clog and fail.
5. Further information can be obtained by contacting your Health Department at 253-7077.

