

49 Hulst Rd.

code enforcement



HULST RD.

N 89°-08'-00" E

167.15'

237

173.69'

197.31'

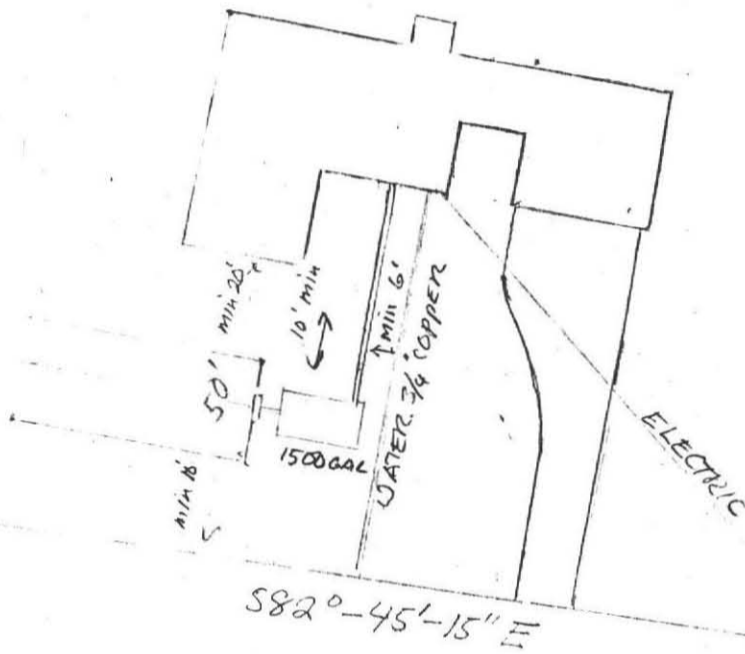

S 82°-45'-15" E



PLOT PLAN,
VERMEX HOUSE
1/32" = 1'-0"

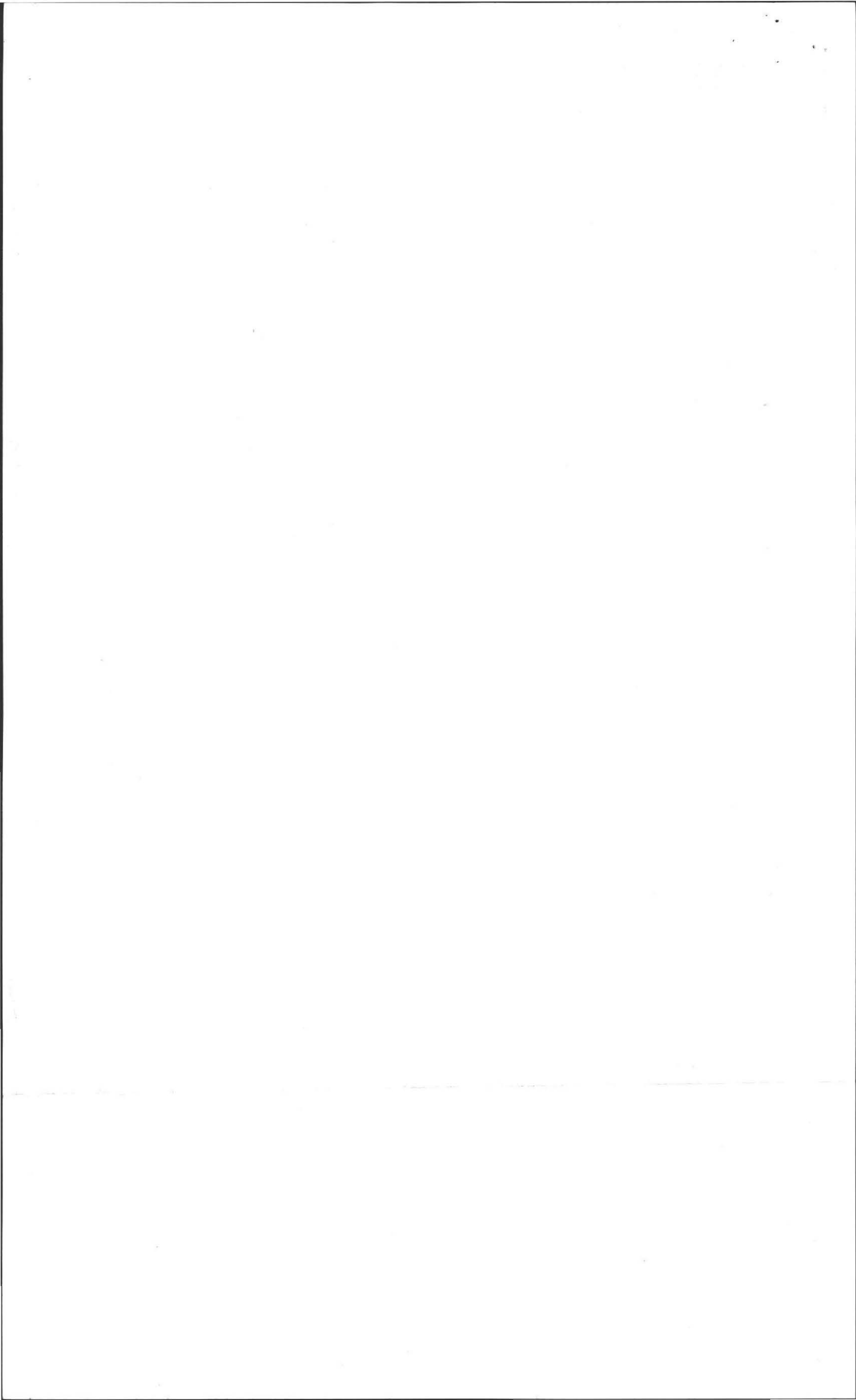

REQUESTED BY: ED MARKERT
 LOCATION: ELF HILL
AMHERST
 MAIL ADDRESS: _____

DATE: 12/31/73
 OBSERVER: W, RB
RS

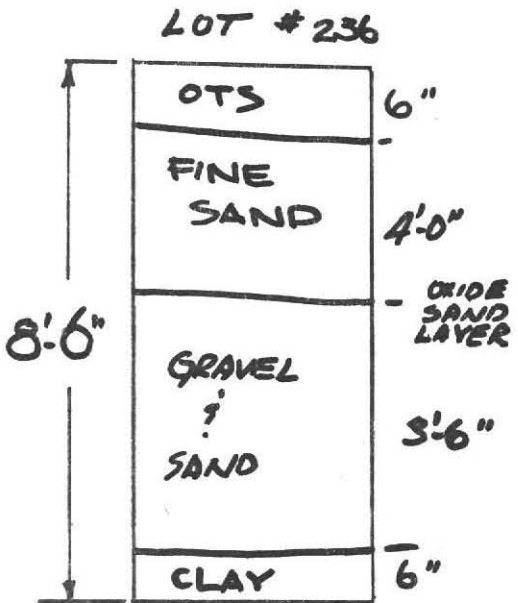

GROUND WATER NONE
 PERC RATE: 2.0 MIN/IN
 TH # 1
 LOT # 238

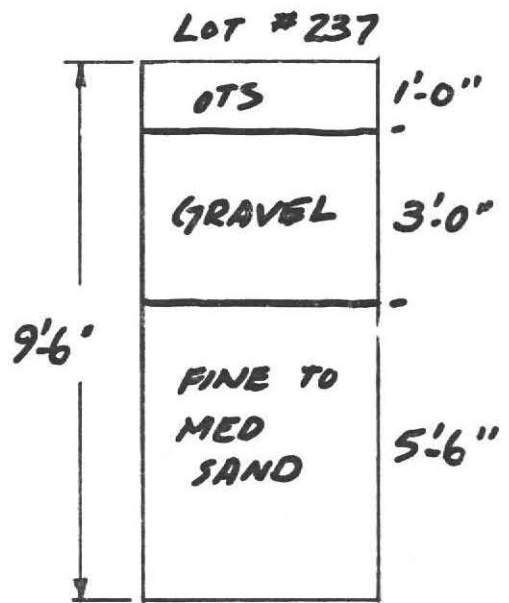

GROUND WATER NONE
 PERC RATE: 2.0 MIN/IN
 TH # 2
 LOT # 238

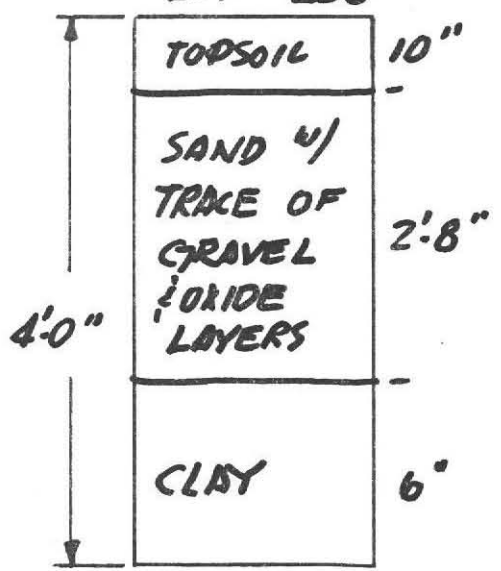

GROUND WATER NONE
 PERC RATE: NO TEST

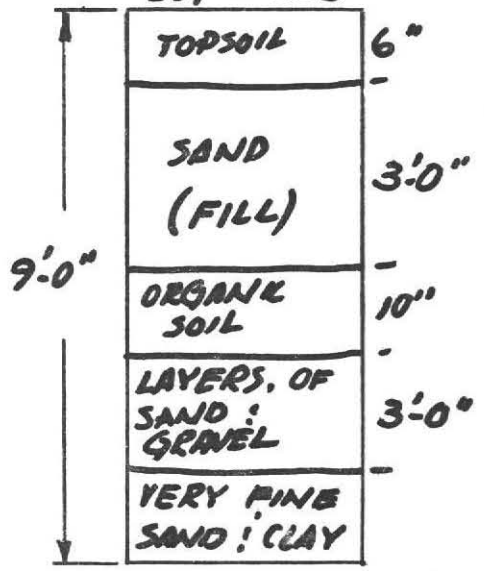

GROUND WATER NONE
 PERC RATE: 3.2 MIN/IN

ALMER HUNTLEY, JR. & ASSOCIATES, INC.
 REGISTERED LAND SURVEYORS & CIVIL ENGINEERS
 238 BRIDGE STREET
 NORTHAMPTON, MASS.

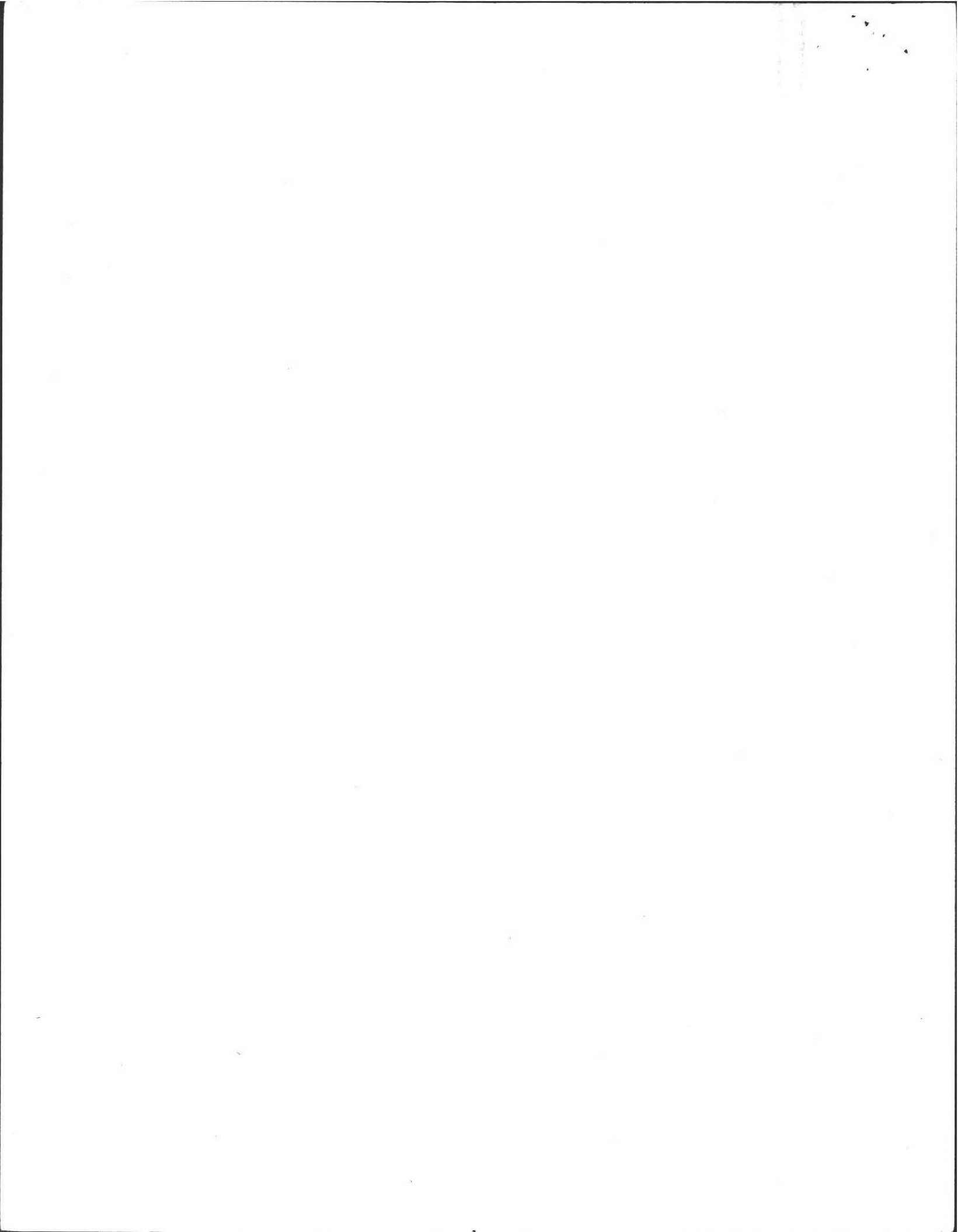

BOARD OF HEALTH
TOWN OF AMHERST, MASSACHUSETTS

Important Information Regarding Your Private Sewage Disposal System

DISPLAY THIS DOCUMENT IN A PROMINENT PLACE

Owner CHARLES VERNER ^{LOT 237 ECF Hill} Address HULST ROAD
Installer KARLS EXC. Address RIVER DE MADLEY
Date Installation Inspected and Approved NOV 22 1976

Description of System: Tank Capacity: 1500

Leach Field () Bed (X) Seepage Pit () Square Feet: 660

Garbage Grinder Yes (X) No () No. Bedrooms: 3 No. People 6

AS - BUILT PLAN:

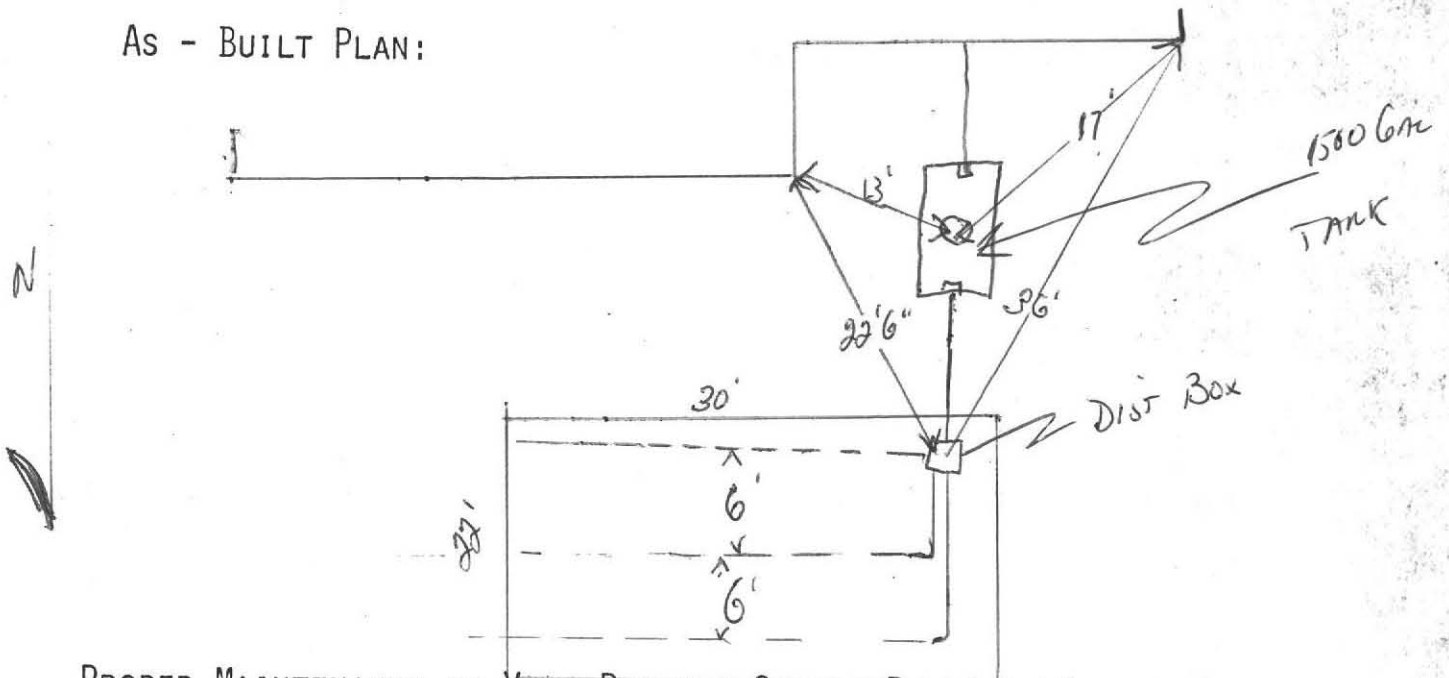

PROPER MAINTENANCE OF YOUR PRIVATE SEWAGE DISPOSAL SYSTEM

1. This system must be inspected periodically and the tank pumped out at an interval not to exceed 2-3 years.
2. For your protection sanitary pumpers are licensed by the Amherst Board of Health.
3. Regular pumping is crucial to avoid early failure and costly repairs of the system.
4. DO NOT dispose into the system such items as rags, string, sanitary napkins, coffee grounds as they can cause it to clog and fail.
5. Further information can be obtained by contacting your Health Department at 253-7077.

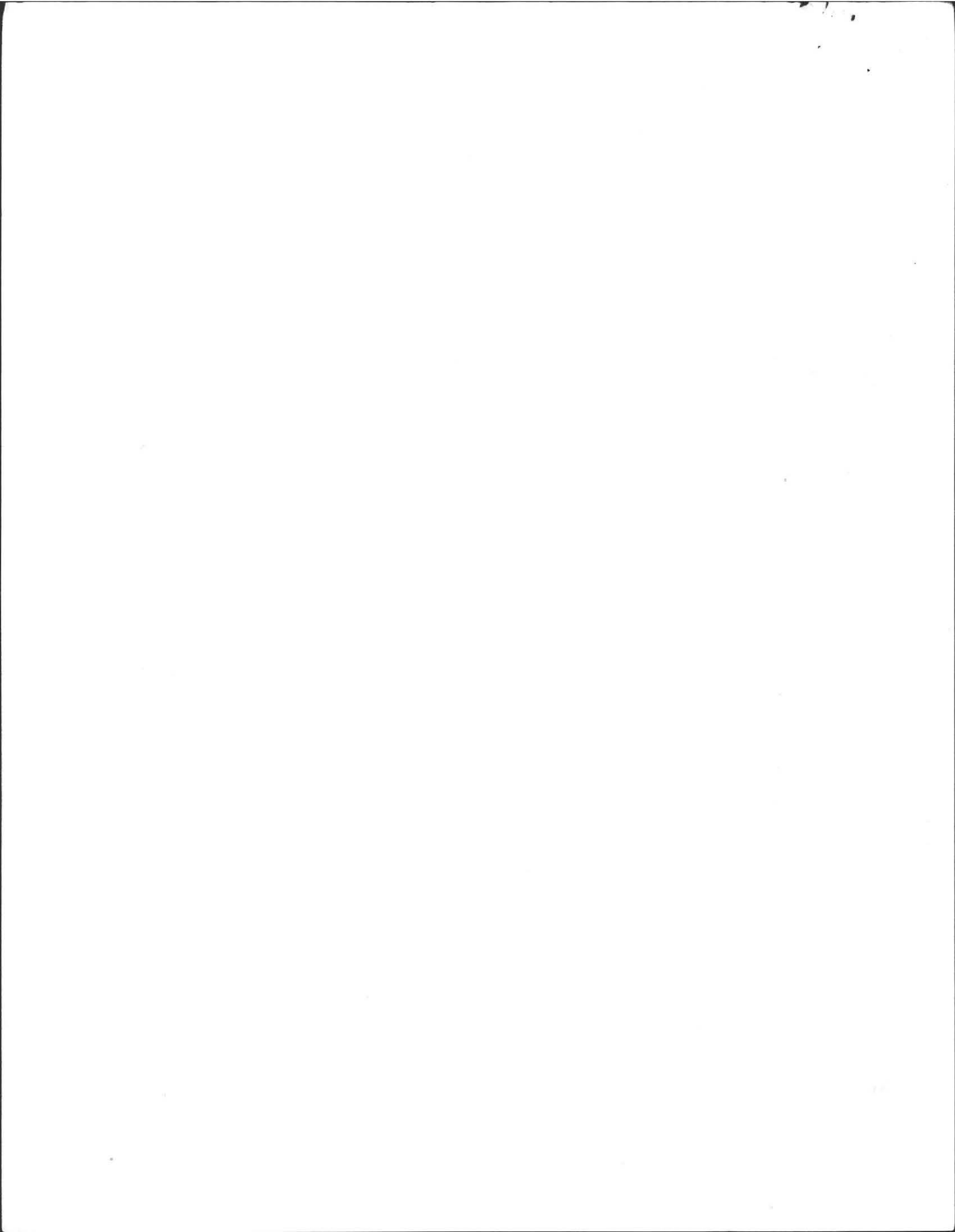

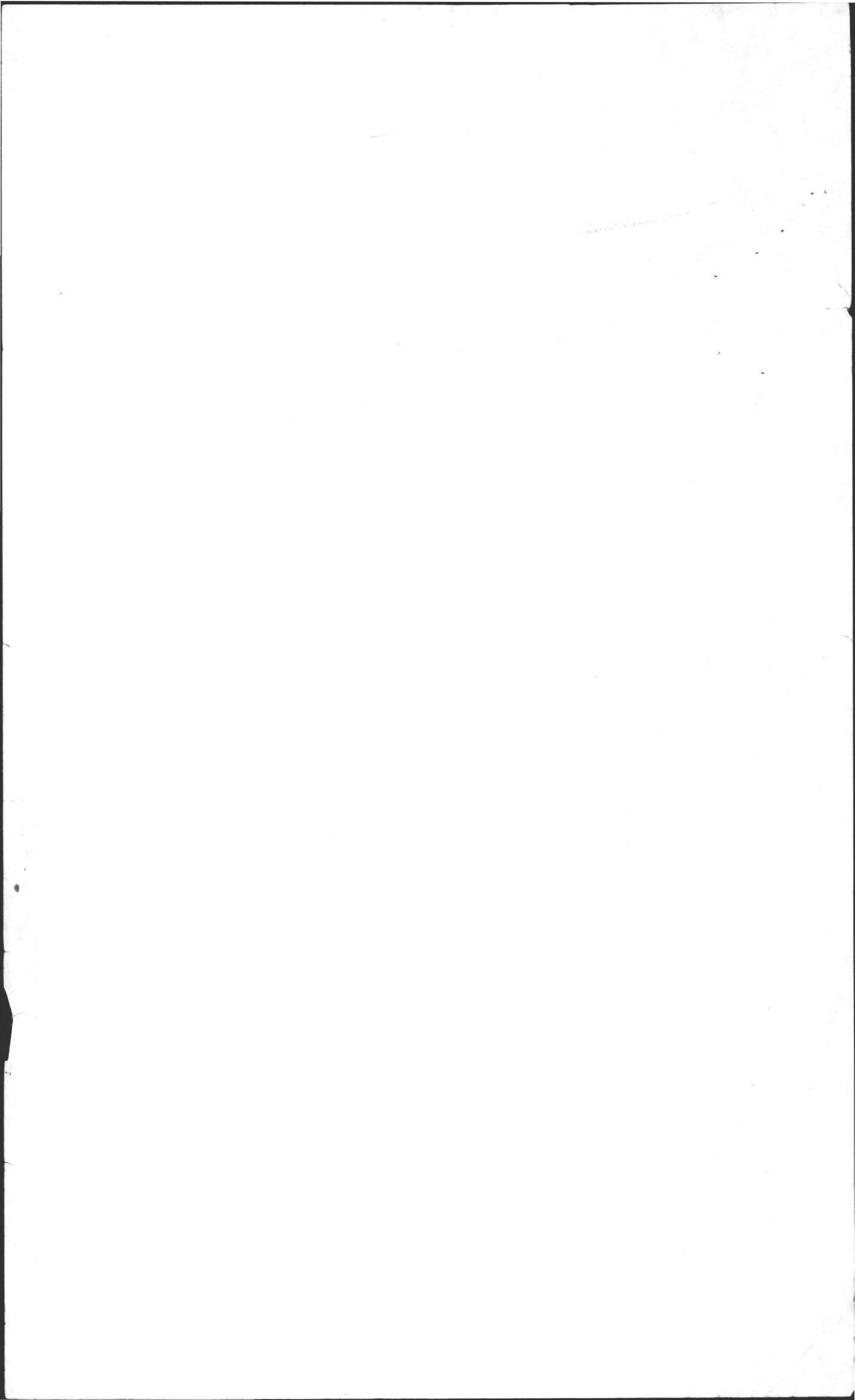

BOARD OF HEALTH, AMHERST, MASSACHUSETTS

#49

APPLICATION FOR DISPOSAL WORKS CONSTRUCTION PERMIT

No. 76-5 Date 3-12-76 Fee 3.00 Date Rec'd. 3-12-76 By [Signature]

Application is hereby made for a permit to Construct (X) or Repair () an Individual Sewage Disposal System at:

Location-Address 49 Hulst Rd, E. Hill Subdivision, HULST RD or Lot No. 237

Owner CHARLES VERNOR Address Box 14 R04 Smiths Ferry

Contractor KARL'S INC Address RIVERDALE HADLEY

Type of Building _____ Dimensions _____ Size Lot .70 ACRES

Dwelling-No. of Bedrooms 3 Expansion Attic (N) Garbage Grinder (X) Other _____ No. of persons _____ Showers ()

Other fixtures _____ Town Water? YES Type of Well _____

Design Flow 50 gallons per person per day. Total daily flow 300 gallons

Septic Tank-Liquid capacity 1500 gallons Dimensions: L _____ W _____ D _____

Disposal Trench-No. _____ Width _____ Total Length _____ Total leaching area _____ sq. ft.

Disposal Bed-No. 1 Diameter 15 Depth below inlet 40 Total leaching area 600 sq. ft.

Dry Well-No. _____ Diameter _____ Depth below inlet _____ Dimensions: _____ x _____ x _____

Other: Distribution box (X) No. _____ Dosing tank ()

(Depth of Soil Line Below finished grade at foundation _____)

Percolation Test Results Performed by GUNTLEY ASSOCIATES Date 12-4-73

Test Pit No. 1 2.0 minutes per inch Depth of Test Pit 3.6"

Test Pit No. 2 3.0 minutes per inch Depth of Test Pit 9.6"

Description of Soil 5' 6" FINE SAND Depth to Ground Water NONE AT 9' 6"

Will disposal area be filled? NO Cut down? NO

(On reverse side or separate sheet, show plot plan with building. Include dimensions, distances from all boundaries. Show location of wells, streams, ledge, large trees, etc.)

AGREEMENT: The undersigned agrees to construct the aforescribed individual sewage disposal system in accordance with the provisions of Article XI of the Sanitary Code and regulations of the Amherst Board of Health. The undersigned further agrees not to place the system in operation until a Certificate of Compliance has been issued by this board of health.

Application Approved by [Signature] Owner or builder [Signature] date 3-12-76

Application Disapproved for the following reasons:

BOARD OF HEALTH, AMHERST, MASSACHUSETTS

CERTIFICATE OF COMPLIANCE

THIS IS TO CERTIFY, That the individual Sewage Disposal System installed () or repaired () by _____ at _____ has been constructed in accordance with the provisions of

INSTALLER

Article XI of the State Sanitary Code as described in the application for Disposal Works Construction Permit No. _____ dated _____

The issuance of this certificate shall not be construed as a guarantee that the system will function satisfactorily.

DATE _____ Inspector _____

BOARD OF HEALTH, AMHERST, MASSACHUSETTS

DISPOSAL WORKS CONSTRUCTION PERMIT

No. 76-5 Permission is hereby granted CHARLES VERNOR to construct (X) or repair () an

Individual Sewage Disposal System at LOT 237 HULST RD

as shown on the application for Disposal Works Construction Permit No. 76-5

This permit is issued with the understanding that future alterations or additions will be made if necessary. This permit shall not be construed as permission to create or maintain any sewage nuisance and in the issuance of this permit the Board of Health assumes no responsibility for the future operation or maintenance of the system.

DATE 3-12-76 Board of Health [Signature]

180

180

180

180

180

180

180

180

180

180

180

180

180

180

180

180

180

180

180

180

180

180

180

180

180

180

180

180

180

180

180

180

180

180

180

180

180

180

180

180

180

180

180

180

180

180

180

180

APPLICATION FOR DISPOSAL WORKS CONSTRUCTION PERMIT

#49

No. _____ Date _____ Fee _____ Date Rec'd. _____ By _____

Application is hereby made for a permit to Construct () or Repair () an Individual Sewage Disposal System at:

Location—Address ELF HILL SUBDIVISION or Lot No. 237

Owner ED MERRITT Address 1200 BAY ROAD, AMHERST

Contractor SAIC Address _____

Type of Building DWELLING Dimensions _____ Size Lot 0.70 ACRES

Dwelling—No. of Bedrooms 4 Expansion Attic () Garbage Grinder ()

Other _____ No. of persons 8 Showers ()

Other fixtures _____

Town Water? _____ Type of Well _____

Design Flow 50 gallons per person per day. Total daily flow 400 gallons

Septic Tank—Liquid capacity 1000 gallons Dimensions: L. 8'-6" W. 4'-10" D. 5'-4"

Disposal Trench—No. 1 Width 15 Total Length 40 Total leaching area 600 sq. ft.

Disposal Bed—No. _____ Diameter _____ Depth below inlet _____ Total leaching area _____ sq. ft.

Dry Well—No. _____ Diameter _____ Depth below inlet _____ Dimensions: _____ x _____ x _____

Other: Distribution box () No. _____ Dosing tank ()

(Depth of Soil Line Below finished grade at foundation _____)

Percolation Test Results Performed by HUNTLEY ASSOCIATES Date 12-4-73

Test Pit No. 1 2.0 minutes per inch Depth of Test Pit 3'-6"

Test Pit No. 2 _____ minutes per inch Depth of Test Pit 9'-6"

Description of Soil 5" OR. TOPSOIL, 3" CR. GRAVEL, 5" OR. FINE TO MED. SAND Depth to Ground Water NEVER

Will disposal area be filled? NO Cut down? NO

(On reverse side or separate sheet, show plot plan with building. Include dimensions, distances from all boundaries. Show location of wells, streams, ledge, large trees, etc.)

AGREEMENT: The undersigned agrees to construct the aforescribed individual sewage disposal system in accordance with the provisions of Article XI of the Sanitary Code and regulations of the Amherst Board of Health. The undersigned further agrees not to place the system in operation until a Certificate of Compliance has been issued by this board of health.

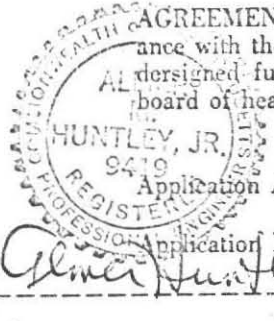

Application Approved by _____ Owner or builder _____ date _____
 _____ date _____

Application Disapproved for the following reasons:
Almer Huntley, Jr.

BOARD OF HEALTH, AMHERST, MASSACHUSETTS CERTIFICATE OF COMPLIANCE

THIS IS TO CERTIFY, That the individual Sewage Disposal System installed () or repaired () by _____ at _____ has been constructed in accordance with the provisions of

INSTALLER
 Article XI of the State Sanitary Code as described in the application for Disposal Works Construction Permit No. _____ dated _____

The issuance of this certificate shall not be construed as a guarantee that the system will function satisfactorily.

DATE _____ Inspector _____

BOARD OF HEALTH, AMHERST, MASSACHUSETTS DISPOSAL WORKS CONSTRUCTION PERMIT

No. _____
 Permission is hereby granted _____ to construct () or repair () an Individual Sewage Disposal System at _____ as shown on the application for Disposal Works Construction Permit No. _____

This permit is issued with the understanding that future alterations or additions will be made if necessary. This permit shall not be construed as permission to create or maintain any sewage nuisance and in the issuance of this permit the Board of Health assumes no responsibility for the future operation or maintenance of the system.

DATE _____ Board of Health _____

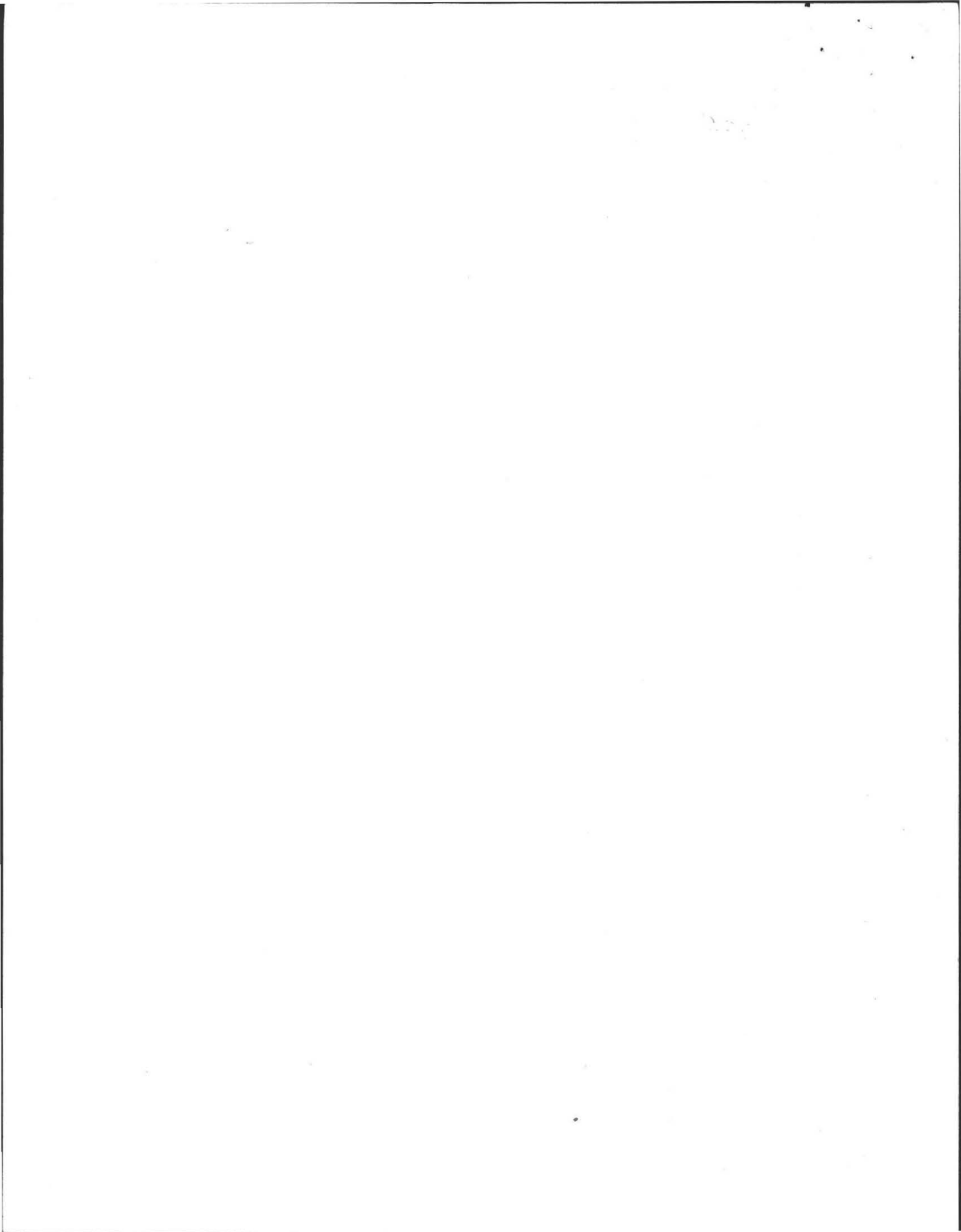

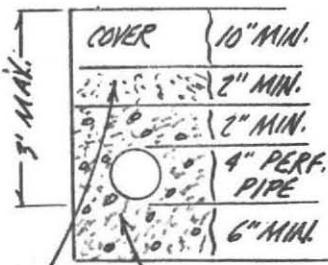

- ALL WORK DONE ACCORDING TO
STATE SAN. CODE ART. II
- PERF. PIPE 6' ON CENTER

18" TO 14" WASHED STONE
3/4" TO 1 1/2" WASHED STONE

HULST ROAD

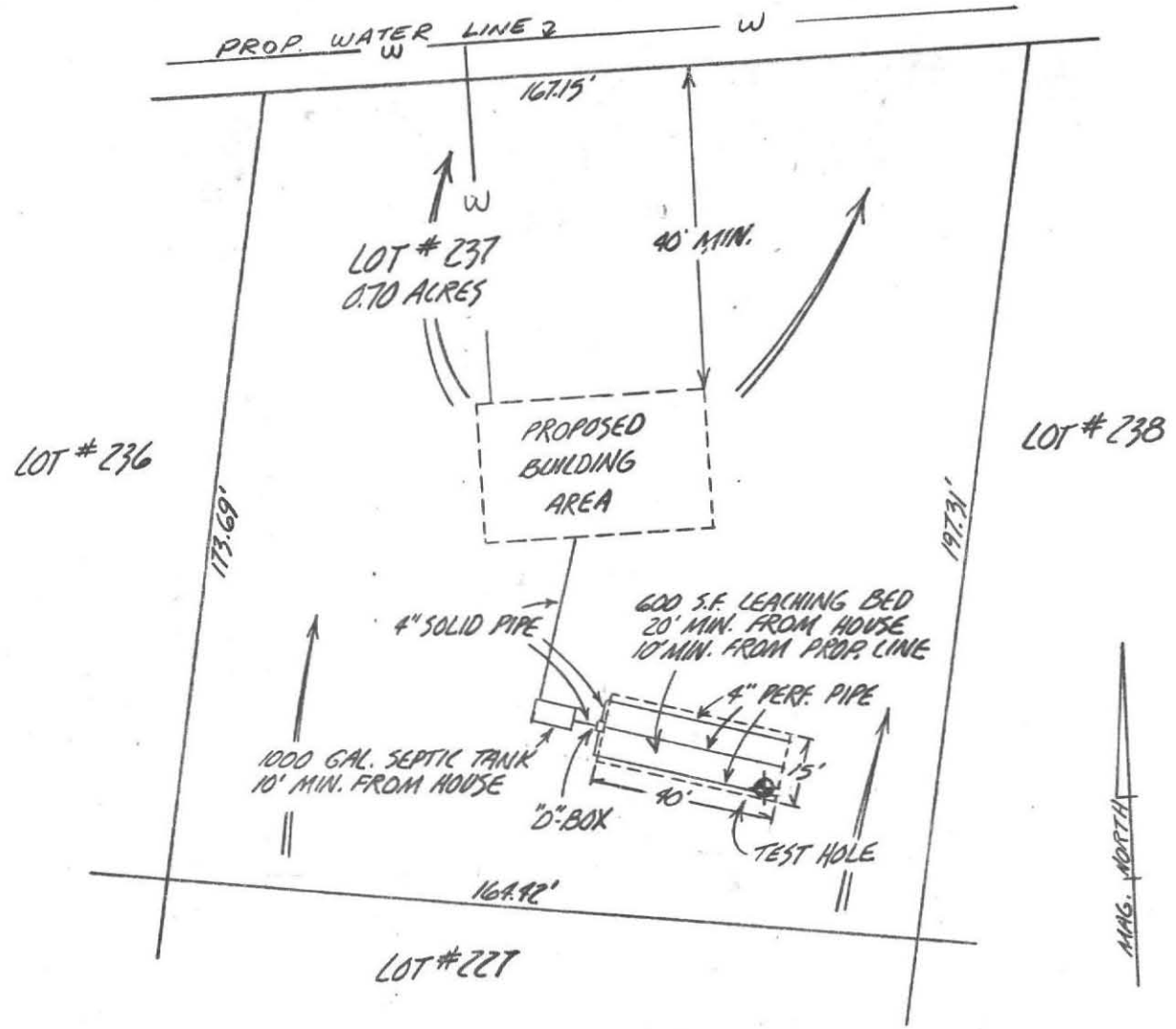

AMHERST, MASS.
PLAN OF PROPOSED
SEWAGE DISPOSAL FIELD
PREPARED FOR
ED MARKERT

Almer M. Huntley, Jr.

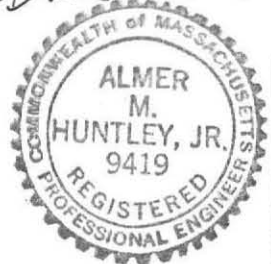

ALMER HUNTLEY, JR. & ASSOCIATES, INC.
REGISTERED LAND SURVEYORS & CIVIL ENGINEERS
238 BRIDGE STREET
NORTHAMPTON, MASS.

SCALE: 1"=40'
12-13-73 R.E.S.

